

SuperStack® 3 Baseline 10/100 Switch 16-Port (3C16470) and 24-Port (3C16471) User Guide

DUA1647-0AAA01

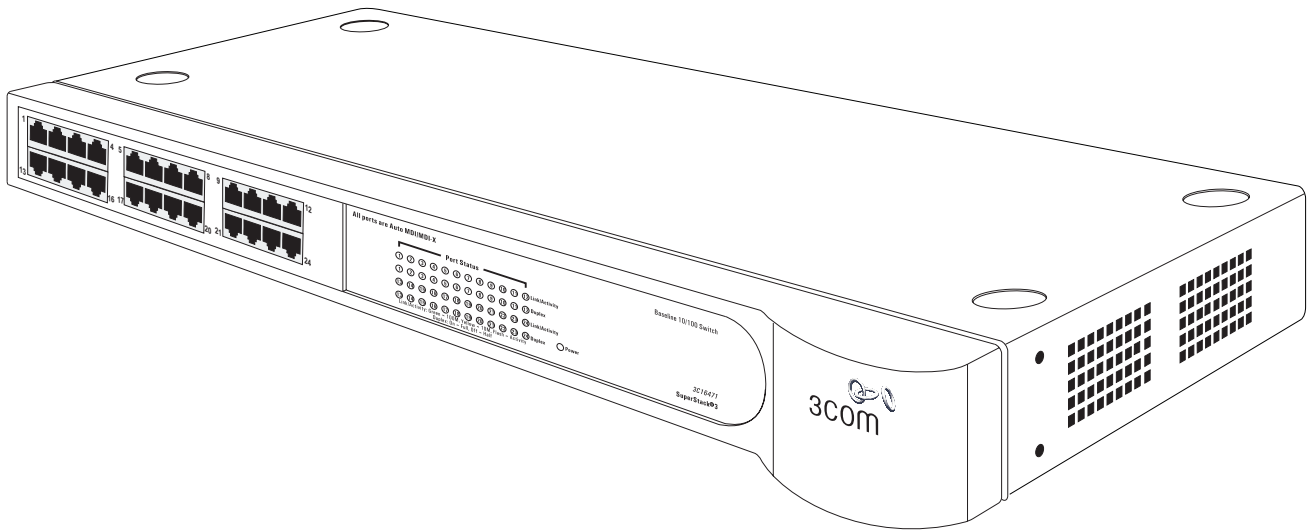

INTRODUCTION

The SuperStack® 3 Baseline 10/100 Switch is a versatile, easy-to-use unmanaged switch. It is ideal for users who want the high-speed performance of 10/100 switching but do not need sophisticated management capabilities. The Baseline 10/100 Switch is shipped ready for use. No configuration is necessary.

The Baseline 10/100 Switch has 16 or 24 shielded RJ-45, 10/100 Mbps auto-negotiating ports on the front panel. Each port automatically determines the speed and duplex mode of the connected equipment and provides a suitable switched connection. Each port also supports automatic MDI/MDI-X detection.

The Baseline 10/100 Switch is suited for office use where it can be free standing, or rack mounted (in a wiring closet or equipment room).

The Baseline 10/100 Switch comes with:

- One power cord for use with the Baseline 10/100 Switch
- Four self-adhesive rubber pads
- One mounting kit

The Switch is powered from the AC mains supply.

The Baseline 10/100 Switch provides high performance switched connections to 10 Mbps and 100 Mbps hubs, servers and workstations that require a dedicated switched link.

The diagram below shows a sample configuration:

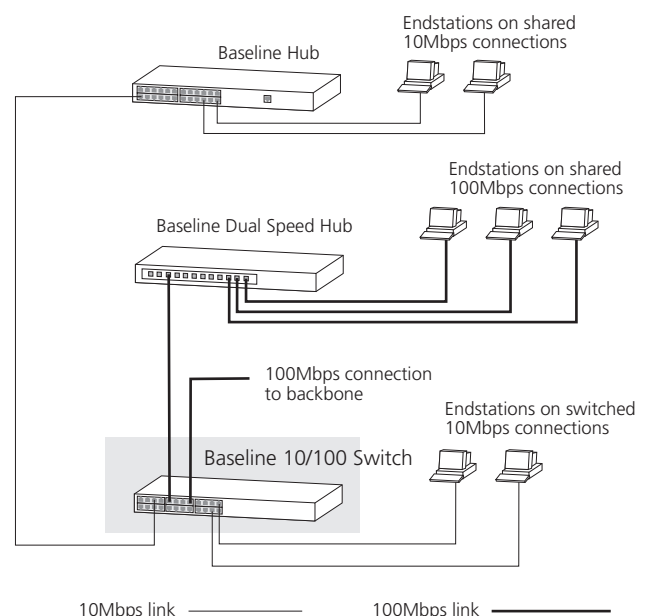

HOW TO USE THE BASELINE 10/100 SWITCH

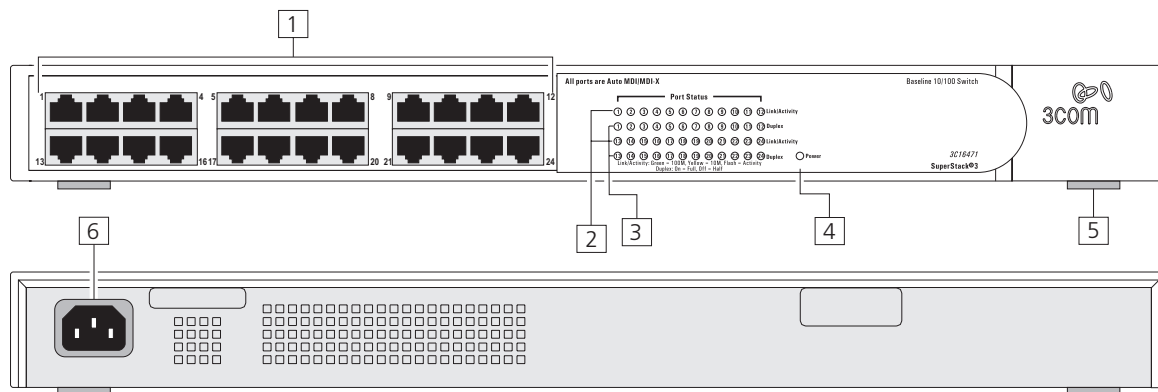

Numbered elements in this diagram refer to numbered sections in the text. A 24-port unit is shown.

Front Panel

1 24 RJ-45 10/100 Ports

WARNING: RJ-45 ports. These are shielded RJ-45 data sockets. They cannot be used as standard traditional telephone sockets, or to connect the unit to a traditional PBX or public telephone network. Only connect RJ-45 data connectors, network telephony systems, or network telephones to these sockets. Either shielded or unshielded data cables with shielded or unshielded jacks can be connected to these data sockets.

AVERTISSEMENT: Les ports RJ-45. Ceux-ci sont protégés par des prises de données. Ils ne peuvent pas être utilisés comme prises de téléphone conventionnelles standard, ni pour la connection de l'unité à un réseau téléphonique central privé ou public. Raccorder seulement connecteurs de données RJ-45, systèmes de réseaux de téléphonie ou téléphones de réseaux à ces prises. Il est possible de raccorder des câbles protégés ou non protégés avec des jacks protégés ou non protégés à ces prises de données.

WARNUNG: RJ-45-Porte. Diese Ports sind geschützte Datensteckdosen. Sie dürfen weder wie normale traditionelle Telefonsteckdosen noch für die Verbindung der Einheit mit einem traditionellem privatem oder öffentlichem Telefonnetzwerk gebraucht werden. Nur RJ-45-Datenanschlüsse, Telefonnetzsysteme or Netztelefone an diese Steckdosen anschließen. Entweder geschützte oder ungeschützte Buchsen dürfen an diese Datensteckdosen angeschlossen werden.

10BASE-T/100BASE-TX Ports

The Baseline 10/100 Switch has 16 (3C16470) or 24 (3C16471) 10/100 Mbps auto-negotiating ports.

To connect a device to the Baseline 10/100 Switch, use Category 5 unshielded or shielded (screened) 100 Ohm TP cable (or Category 3 cable for a 10 Mbps connection). The maximum length of cable for each connection is 100m (328ft). Connect one end of the cable to an RJ-45 port on the Baseline 10/100 Switch, and the other end to the appropriate RJ-45 port on the connecting device.

Each port on the Baseline 10/100 Switch is auto-negotiating: its speed and duplex mode (half duplex or full duplex) are automatically determined by the capabilities of the connected device.

Each port supports automatic MDI/MDI-X detection and can be connected to either a 10BASE-T or a 100BASE-TX device.

The Switch offers priority queuing, which means all packets that are received are examined to see if they have been priority encoded. If a packet has been then the Switch will read the priority level and determine whether the packet should be directed through the normal or high priority channel. This feature can be useful for example during excessive loads when one type of traffic may require priority over another. The Switch is configured to comply with 802.1p, VLAN tagged frames.

Traffic prioritization ensures that high priority data is forwarded through the Switch without being delayed by lower priority data. It differentiates traffic into classes and prioritizes those classes automatically. Traffic prioritization uses the multiple traffic queues that are present in the hardware of the Switch to ensure that high priority traffic is forwarded on a different queue from lower priority traffic, and is given preference over that traffic. This ensures that time-sensitive traffic gets the highest level of service. The 802.1D standard specifies eight distinct levels of priority (0 to 7), each of which relates to a particular type of traffic. The priority levels and their traffic types are shown in the following table.

Priority Level	Traffic Type
0	Best Effort
1	Background
2	Standard (spare)
3	Excellent Effort (business critical)
4	Controlled Load (streaming multimedia)
5	Video (Interactive media), less than 100 milliseconds latency and jitter.
6	Voice (Interactive voice), less than 10 milliseconds latency and jitter.
7	Network Control Reserved traffic



The traffic prioritization feature supported by the Switch is compatible with the relevant sections of the IEEE 802.1D standard (incorporating IEEE 802.1p).



If you connect two Baseline 10/100 Switch units together, the link between them operates at 100 Mbps full duplex. You must use Category 5 cable when connecting the units.



CAUTION: The Baseline 10/100 Switch supports full duplex auto-negotiation. If the connected device does not support auto-negotiation, the Switch will operate in half duplex mode (even if the device is operating in full duplex mode). In such a configuration, you may notice some degradation of network performance. 3Com recommends that you use devices that are capable of auto-negotiation (and that you ensure that auto-negotiation is enabled, if it is a configurable option).

2 Activity/Link/Speed Status LEDs

The first (top) and third row of LEDs, which are colored yellow or green, show the activity and speed status of the related ports:

Status	Meaning
On	The link has been established.
Flashing	Packets are being received or transmitted on the port.
Off	If the link has not been established, either nothing is connected to the port, or there is a problem: <ul style="list-style-type: none"> ■ Check that the attached device is powered on. ■ Check that the cable is the correct type and is not faulty. If these checks do not identify the cause of the problem, it may be that the unit or the device connected to the port is faulty. Contact your supplier for further advice.
Green	The link is operating at 100 Mbps.
Yellow	The link is operating at 10 Mbps.

3 Duplex Status LEDs

The second and fourth (bottom) row of Status LEDs, which are colored yellow, show the duplex status of the related ports:

Status	Meaning
On Yellow	The port is operating in full-duplex mode.
Off	The port is operating in half-duplex mode.

4 Power LED

The Power LED shows the power status of the Switch:

Status	Meaning
On Green	The unit is powered on and ready for use.
Off	The unit is not receiving power: <ul style="list-style-type: none"> ■ Check the power cord is connected correctly. ■ If the unit still does not operate, contact your supplier.

5 Self-adhesive Pads

The unit is supplied with four self-adhesive rubber pads.



You do not need to apply the pads if you intend to rack mount the unit.

If the unit is to be part of a free standing stack, apply the pads to each marked corner area on the underside of the unit. Place the unit on top of the lower unit, ensuring that the pads locate with the recesses of the lower unit.

Rear Panel Connections

6 Power Supply

The Baseline 10/100 Switch automatically adjusts to the supply voltage. Only use the power cord that is supplied with the Baseline 10/100 Switch.

INSTALLING THE SWITCH

Positioning the Baseline 10/100 Switch



CAUTION: If installing the Baseline 10/100 Switch in a stack of different size SuperStack 3 units, the smaller units must be installed above the larger ones. Do not have a free-standing stack of more than six units.

When deciding where to position the Baseline 10/100 Switch ensure that:

- It is accessible and cables can be connected easily.
- Cabling is away from sources of electrical noise such as radios, transmitters and broadband amplifiers, and away from power lines and fluorescent lighting fixtures.
- The Switch is situated away from sources of electrically conductive dust, for example laser printers.
- The AC supply used by the Switch is separate to those used by units that generate high levels of AC noise, for example air conditioning units and laser printers.
- Water or moisture cannot enter the case of the unit.
- Air flow around the unit and through the vents in the side of the case is not restricted (3Com recommends that you provide a minimum of 25 mm (1 in.) clearance).

To prolong the operational life of your units:

- Never stack units more than six high if free-standing, and ensure that cables are supported so that they do not cause the stack to fall over.
- Do not place objects on top of any unit or stack.
- Do not obstruct any vents at the sides of the case.

Rack Mounting

The Baseline 10/100 Switch can be mounted in a 19-inch equipment rack using the Mounting Kit. Refer to "Mounting Kit Instructions" on page 5.

Power Up

Use the following sequence to power up the Baseline 10/100 Switch:

- 1 Check the network connections and cables.
- 2 Connect the power supply cable to the appropriate power socket on the rear panel of the unit; refer to **6 Power Supply**.
- 3 Connect the plug to the power supply outlet socket and switch on the power supply at the socket.

When the switch is powered on, the Power LED should be lit on green. If it is not, refer to **4 Power LED**.

Spot Checks

At frequent intervals you should visually check the Baseline 10/100 Switch. Regular checks can give you an early warning of a possible failure; any problems can then be attended to when there will be least effect on users. Check that all external cabling connections are secure and that no cables are pulled taut.

If you experience any problems operating the Baseline 10/100 Switch, refer to "Problem Solving" on page 5.

SAFETY INFORMATION

Please read the following safety information carefully before installing the Baseline 10/100 Switch.



WARNING: Installation and removal of the unit must be carried out by qualified personnel only.

- If installing the Switch unit in a stack with other SuperStack 3 units, the Baseline 10/100 Switch unit must be installed below the narrower Hub units.
- The unit must be connected to an earthed (grounded) outlet to comply with international safety standards.
- Do not connect the unit to an A.C. outlet (power supply) without an earth (ground) connection.
- The appliance coupler (the connector to the unit and not the wall plug) must have a configuration for mating with an EN60320/IEC320 appliance inlet.
- The socket outlet must be near to the unit and easily accessible. You can only remove power from the unit by disconnecting the power cord from the outlet.
- This unit operates under SELV (Safety Extra Low Voltage) conditions according to IEC 60. The conditions are only maintained if the equipment to which it is connected also operates under SELV conditions.

France and Peru only

This unit cannot be powered from IT[†] supplies. If your supplies are of IT type, this unit must be powered by 230V (2P+T) via an isolation transformer ratio 1:1, with the secondary connection point labelled Neutral, connected directly to earth (ground).

† Impédance à la terre

Power Cord Set

This must be approved for the country where it will be used. e.g.

- | | |
|-------------------|--|
| U.S.A. and Canada | <ul style="list-style-type: none">■ The cord set must be UL-approved and CSA certified.■ The minimum specifications for the flexible cord are:
No. 18 AWG
Type SV or SJ
3-conductor■ The cord set must have a rated current capacity of at least 10A.■ The attachment plug must be an earth-grounding type with a NEMA 5-15P (15 A, 125 V) or NEMA 6-15P (15 A, 250 V) configuration. |
| Denmark | <ul style="list-style-type: none">■ The supply plug must comply with Section 107-2-D1, Standard DK2-1a or DK2-5a. |
| Switzerland | <ul style="list-style-type: none">■ The supply plug must comply with SEV/ASE 1011. |
| UK | <ul style="list-style-type: none">■ The supply plug must comply with BS1363 (3-pin 13-amp) and be fitted with a 5 A fuse which complies with BS1362.■ The mains cord must be <HAR> or <BASEC> marked and be of type HO3VVF3GO.75 (minimum). |
| Europe | <ul style="list-style-type: none">■ The supply plug must comply with CEE7/7 ("SCHUKO")■ The mains cord must be <HAR> or <BASEC> marked and be of type HO3VVF3GO.75 (minimum). |

L'INFORMATION DE SÉCURITÉ IMPORTANTE

Veillez lire à fond l'information de la sécurité suivante avant d'installer le Baseline 10/100 Switch.



AVERTISSEMENT: L'installation et la dépose de ce groupe doivent être confiés à un personnel qualifié.

- Si vous entassez l'unité Switch avec les unités SuperStack 3, l'unité Baseline 10/100 Switch doit être installée en dessous des unités Hub plus étroites.
- Ne branchez pas votre appareil sur une prise secteur (alimentation électrique) lorsqu'il n'y a pas de connexion de mise à la terre (mise à la masse).
- Vous devez raccorder ce groupe à une sortie mise à la terre (mise à la masse) afin de respecter les normes internationales de sécurité.
- Le coupleur d'appareil (le connecteur du groupe et non pas la prise murale) doit respecter une configuration qui permet un branchement sur une entrée d'appareil EN60320/IEC 320.
- La prise secteur doit se trouver à proximité de l'appareil et son accès doit être facile. Vous ne pouvez mettre l'appareil hors circuit qu'en débranchant son cordon électrique au niveau de cette prise.
- L'appareil fonctionne à une tension extrêmement basse de sécurité qui est conforme à la norme IEC60950. Ces conditions ne sont maintenues que si l'équipement auquel il est raccordé fonctionne dans les mêmes conditions.
- Branchez uniquement un *Advanced Redundant Power System* (3C16070, 3C16071, 3C16071A ou 3C16071B) ou un *Redundant Power System* (3C565047) sur la prise femelle du *Redundant Power System*.

France et Pérou uniquement:

Ce groupe ne peut pas être alimenté par un dispositif à impédance à la terre. Si vos alimentations sont du type impédance à la terre, ce groupe doit être alimenté par une tension de 230 V (2 P+T) par le biais d'un transformateur d'isolement à rapport 1:1, avec un point secondaire de connexion portant l'appellation Neutre et avec raccordement direct à la terre (masse).

Cordon électrique

Il doit être agréé dans le pays d'utilisation.

- | | |
|-----------------------|--|
| Etats-Unis et Canada: | <ul style="list-style-type: none">■ Le cordon doit avoir reçu l'homologation des UL et un certificat de la CSA.■ Le cordon souple doit respecter, à titre minimum, les spécifications suivantes:
calibre 18 AWG
type SV ou SJ
à 3 conducteurs■ Le cordon doit être en mesure d'acheminer un courant nominal d'au moins 10 A.■ La prise femelle de branchement doit être du type à mise à la terre (mise à la masse) et respecter la configuration NEMA 5-15P (15 A, 125 V) ou NEMA 6-15P (15 A, 250 V). |
| Danemark: | <ul style="list-style-type: none">■ La prise mâle d'alimentation doit respecter la section 107-2 D1 de la norme DK2 1a ou DK2 5a. |
| Suisse: | <ul style="list-style-type: none">■ La prise mâle d'alimentation doit respecter la norme SEV/ASE 1011. |
| Europe | <ul style="list-style-type: none">■ La prise secteur doit être conforme aux normes CEE 7/7 ("SCHUKO")■ LE cordon secteur doit porter la mention <HAR> ou <BASEC> et doit être de type HO3VVF3GO.75 (minimum). |

WICHTIGE SICHERHEITSINFORMATIONEN

Bitte unbedingt vor dem Einbauen des Baseline 10/100 Switch Einheit die folgenden Sicherheitsanweisungen durchlesen.



WARNUNG: Die Installation und der Ausbau des Geräts darf nur durch Fachpersonal erfolgen.

- Wenn die Baseline 10/100 Switch Einheit in einer Stapel mit anderen SuperStack 3 Einheiten eingebaut werden soll, muß die Baseline 10/100 Switch Einheit unter die schmalere Hub Einheiten eingebaut werden.
- Das Gerät nicht an eine Wechselstromsteckdose anschließen, die nicht geerdet ist.
- Das Gerät muß an eine geerdete Steckdose angeschlossen werden, die die internationalen Sicherheitsnormen erfüllt.
- Der Gerätestecker (der Anschluß an das Gerät, nicht der Wandsteckdosenstecker) muß eine passende Konfiguration für einen Geräteeingang gemäß EN60320/IEC320 haben.

- Die Netzsteckdose muß in der Nähe des Geräts und leicht zugänglich sein. Die Stromversorgung des Geräts kann nur durch Herausziehen des Gerätenetzkabels aus der Netzsteckdose unterbrochen werden.
- Der Betrieb dieses Geräts erfolgt unter den SELV-Bedingungen (Sicherheitskleinstspannung) gemäß IEC 60. Diese Bedingungen sind nur gegeben, wenn auch die an das Gerät angeschlossenen Geräte unter SELV-Bedingungen betrieben werden.
- Nur ein *Advanced Redundant Power System* (3C16070, 3C16071, 3C16071A oder 3C16071B) oder *Redundant Power System* (3C565047) an den *Redundant Power System* Anschluß anschließen.

Stromkabel. Dies muss von dem Land, in dem es benutzt wird geprüft werden:

- | | |
|---------|--|
| Schweiz | <ul style="list-style-type: none">■ Dieser Stromstecker muß die SEV/ASE 1011 Bestimmungen einhalten. |
| Europe | <ul style="list-style-type: none">■ Das Netzkabel muß vom Typ HO3VVF3GO.75 (Mindestanforderung) sein und die Aufschrift <HAR> oder <BASEC> tragen.■ Der Netzstecker muß die Norm CEE 7/7 erfüllen ("SCHUKO"). |

MOUNTING KIT INSTRUCTIONS

Introduction

The Baseline 10/100 Switch is supplied with two mounting brackets and four screws. These are used for rack-mounting the unit. When mounting the unit, you should take note of the guidelines given in "Positioning the Baseline 10/100 Switch" on page 3.

Rack Mounting the Units

The Baseline 10/100 Switch is 1U high and will fit a standard 19-inch rack.



CAUTION: Disconnect all cables from the unit before continuing. Remove the self-adhesive pads from the underside of unit, if already fitted.

- 1 Place the unit the right way up on a hard, flat surface with the front facing towards you.
- 2 Locate a mounting bracket over the mounting holes on one side of the unit (refer to the figure following step 6).

- 3 Insert the two screws supplied in the mounting kit and fully tighten with a suitable screwdriver.
- 4 Repeat the two previous steps for the other side of the unit.
- 5 Insert the unit into the 19-inch rack and secure with suitable screws (not provided).
- 6 Reconnect all cables.

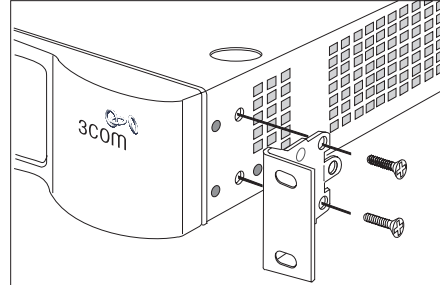

PROBLEM SOLVING

Refer to the information about LEDs given earlier in this guide to see if the problem can be identified and rectified. Here are some common problems that can occur:

Link Status LED not lit for a port that has a connection.

There is a problem with this connection. Check that:

- The device being connected to is powered on and operating correctly.
- The cable is connected at both ends.
- The cable is not damaged.
- If the connection is to a workstation, that the workstation's network interface is installed and configured correctly.

All ports appear to show continual activity. There may be broadcast storms on the network.

Remove port connections one at a time, waiting a few seconds between each port. If the LEDs go off after removing a port connection, the device that was connected to that port is introducing an excessive amount of broadcast frames to the network (some pieces of network equipment operate by sending out broadcast frames regularly). Refer to the documentation that accompanies the device for information on disabling the broadcast operation.

If the problem persists and the unit still does not operate successfully, contact your supplier with the following information before returning the unit:

- Product number and serial number (printed on a label supplied with the unit)
- A brief description of the fault

TECHNICAL INFORMATION

Related Standards

The SuperStack 3 Baseline 10/100 Switch has been designed to the following standards:

Functional	ISO 8802-3, IEEE 802.3 (Ethernet), IEEE 802.3u (Fast Ethernet), IEEE 802.3x (Flow Control), IEEE 802.3d (Bridging)
Safety	UL 1950, EN 60950, CSA 22.2 #950, IEC 60950
EMC Emissions	EN 55022 Class A, FCC Part 15 Subpart B Class A, ICES-003 Class A, VCCI Class A, AS/NZS 3548 Class A, CNS 13438 Class A
Immunity	EN 55024

Environmental

Operating Temperature	0–40 °C (32–104 °F)
Humidity	10–95% (non-condensing)

Physical

Width	440 mm (17.3 in.)
Depth	173 mm (6.8 in.)
Height	44 mm (1.7 in.) or 1U
Weight	2.6 kg (5.8 lb)
Mounting	Free standing, or 19 in. rack mounted using the mounting kit supplied

Electrical

Power Inlet	IEC 320
AC Line Frequency	50/60 Hz
Input Voltage	100–240 VAC
Current Rating	1 Amps (maximum)
Maximum Power Consumption	3C16470: 15 VA 3C16471: 20 VA
Maximum Power Dissipation	3C16470: 52 BTU/hr 3C16471: 68 BTU/hr

REGULATORY NOTICES

FCC Statement

This equipment has been tested and found to comply with the limits for a Class A digital device, pursuant to part 15 of the FCC rules. These limits are designed to provide reasonable protection against harmful interference when the equipment is operated in a commercial environment. This equipment generates, uses and can radiate radio frequency energy and, if not installed and used in accordance with the instructions, may cause harmful interference to radio communications. Operation of this equipment in a residential area is likely to cause harmful interference to radio communications, in which case the user will be required to correct the interference at their own expense.

Information To The User

If this equipment does cause interference to radio or television reception, which can be determined by turning the equipment off and on, the user is encouraged to try to correct the interference by one or more of the following measures:

- Reorient the receiving antenna.
- Relocate the equipment with respect to the receiver.
- Move the equipment away from the receiver.
- Plug the equipment into a different outlet so that equipment and receiver are on different branch circuits.

If necessary, the user should consult the dealer or an experienced radio/television technician for additional suggestions. The user may find the following booklet prepared by the Federal Communications Commission helpful:

How to Identify and Resolve Radio-TV Interference Problems

This booklet is available from the U.S. Government Printing Office, Washington,

DC 20402, Stock No. 004-000-00345-4.

In order to meet FCC emissions limits, this equipment must be used only with cables which comply with IEEE 802.3.

CE Statement (Europe)

This product complies with the European Low Voltage Directive 73/23/EEC and ETIC Directive 89/336/EEC as amended by European Directive 93/68/EEC/.

CSA Statement

This Class A digital apparatus meets all requirements of the Canadian Interference-Causing Equipment Regulations.

Cet appareil numérique de la classe A respecte toutes les exigences du Règlement sur le matériel brouilleur du Canada.

VCCI Statement

この装置は、情報処理装置等電波障害自主規制協議会（VCCI）の基準に基づくクラスA情報技術装置です。この装置を家庭環境で使用すると電波妨害を引き起こすことがあります。この場合には使用者が適切な対策を講ずるよう要求されることがあります。

BSMI Statement

警告使用者：這是甲類的資訊產品，在居住的環境中使用時，可能會造成射頻干擾，在這種情況下，使用者會被要求採取某些適當的對策。

TECHNICAL SUPPORT

The following options are available for technical support:

- In the first instance contact your Network Supplier.
- Check the 3Com knowledgebase at <http://knowledgebase.3com.com>
- Browse the 3Com web site on <http://www.3com.com>

Please have your product model name, part number, hardware revision number and serial number along with all relevant details of the problem to hand before calling your Network Supplier or 3Com on the numbers below.

Country	Telephone Number	Country	Telephone Number
Asia, Pacific Rim			
Australia	1 800 678 515	Philippines	1235 61 266 2602 or
Hong Kong	800 933 486		+61 2 9937 5076
India	+61 2 9424 5179 or	P.R. of China	10800 61 00137 or
	000800 650 1111		021 6350 1590 or
Indonesia	001 803 61009		00800 0638 3266
Japan	00531 616 439 or	Singapore	800 6161 463
	03 5977 7991	S. Korea	00798 611 2230 or
Malaysia	1800 801 777		02 3455 6455
New Zealand	0800 446 398	Taiwan	0080 611 261
Pakistan	+61 2 9937 5083	Thailand	001 800 611 2000

Europe, Middle East and Africa

From anywhere in these regions, call: +44 (0)1442 435529 phone
+44 (0)1442 432524 fax

Country	Telephone Number	Country	Telephone Number
From the following countries, you may use the toll-free numbers:			
Austria	0800 297468	Luxembourg	0800 3625
Belgium	0800 71429	Netherlands	0800 0227788
Denmark	800 17309	Norway	800 11376
Finland	0800 113153	Poland	00800 3111206
France	0800 917959	Portugal	800 831416
Germany	0800 1821502	South Africa	0800 995014
Hungary	06800 12813	Spain	900 983125
Ireland	1800 553117	Sweden	020 795482
Israel	1800 9453794	Switzerland	0800 55 3072
Italy	800 879489	U.K.	0800 966197
Latin America			
From the Caribbean, Central and South America, call:			
Antigua	1 800 988 2112	Guatemala	AT&T +800 998 2112
Argentina	0 810 444 3COM	Haiti	57 1 657 0888
Aruba	1 800 998 2112	Honduras	AT&T +800 998 2112
Bahamas	1 800 998 2112	Jamaica	1 800 998 2112
Barbados	1 800 998 2112	Martinique	571 657 0888
Belize	52 5 201 0010	Mexico	01 800 849CARE
Bermuda	1 800 998 2112	Nicaragua	AT&T +800 998 2112
Bonaire	1 800 998 2112	Panama	AT&T +800 998 2112
Brazil	0800 13 3COM	Paraguay	54 11 4894 1888
Cayman	1 800 998 2112	Peru	AT&T +800 998 2112
Chile	AT&T +800 998 2112	Puerto Rico	1 800 998 2112
Colombia	AT&T +800 998 2112	Salvador	AT&T +800 998 2112
Costa Rica	AT&T +800 998 2112	Trinidad and Tobago	1 800 998 2112
Curacao	1 800 998 2112	Uruguay	AT&T +800 998 2112
Ecuador	AT&T +800 998 2112	Venezuela	AT&T +800 998 2112
Dominican Republic	AT&T +800 998 2112	Virgin Islands	57 1 657 0888
North America	1 800 876 3266		

LEGAL NOTICES

© 3Com Technologies, 2002. All rights reserved. No part of this documentation may be reproduced in any form or by any means or used to make any derivative work (such as translation, transformation, or adaptation) without permission from 3Com Technologies.

3Com Technologies reserves the right to revise this documentation and to make changes in content from time to time without obligation on the part of 3Com Technologies to provide notification of such revision or change.

3Com Technologies provides this documentation without warranty of any kind, either implied or expressed, including, but not limited to, the implied warranties of merchantability and fitness for a particular purpose. 3Com may make improvements or changes in the product(s) and/or the program(s) described in this documentation at any time.

UNITED STATES GOVERNMENT LEGENDS:

If you are a United States government agency, then this documentation and the software described herein are provided to you subject to the following restricted rights:

For units of the Department of Defense:

Restricted Rights Legend: Use, duplication or disclosure by the Government is subject to restrictions as set forth in subparagraph (c) (1) (ii) for restricted Rights in Technical Data and Computer Software clause at 48 C.F.R. 52.227-7013. 3Com

Centre, Boundary Way, Maylands Park South, Hemel Hempstead, Herts, HP2 7YU, U.K.

For civilian agencies:

Restricted Rights Legend: Use, reproduction or disclosure is subject to restrictions set forth in subparagraph (a) through (d) of the Commercial Computer Software - Restricted Rights Clause at 48 C.F.R. 52.227-19 and the limitations set forth in 3Com Corporation's standard commercial agreement for the software. Unpublished rights reserved under the copyright laws of the United States.

If there is any software on removable media described in this documentation, it is furnished under a license agreement included with the product as a separate document, in the hard copy documentation, or on the removable media in a directory file named LICENSE.TXT. If you are unable to locate a copy, please contact 3Com and a copy will be provided to you.

Unless otherwise indicated, 3Com registered trademarks are registered in the United States and may or may not be registered in other countries.

3Com and SuperStack are registered trademarks of 3Com Corporation.

Other brand and product names may be registered trademarks or trademarks of their respective holders.

ENVIRONMENTAL STATEMENTS

General Environmental Statement

It is the policy of 3Com Corporation to be environmentally-friendly in all operations. To uphold our policy, we are committed to:

- Establishing environmental performance standards that comply with national legislation and regulations
- Conserving energy, materials and natural resources in all operations
- Reducing the waste generated by all operations
- Ensuring that all waste conforms to recognized environmental standards
- Maximizing the recyclable and reusable content of all products
- Ensuring that all products can be recycled, reused and disposed of safely
- Ensuring that all products are labelled according to recognized environmental standards
- Improving our environmental record on a continual basis

End Of Life Statement

3Com processes allow for the recovery, reclamation and safe disposal of all end-of-life electronic components.

Regulated Materials Statement

3Com products do not contain any hazardous or ozone-depleting material.

Environmental Statement about the Documentation

The documentation for this product is printed on paper that comes from sustainable, managed forests; it is fully biodegradable and recyclable, and is completely chlorine-free. The varnish is environmentally-friendly, and the inks are vegetable-based with a low heavy-metal content.

Product Registration

You can now register your SuperStack 3 Baseline 10/100 Switch on the 3Com web site:

<http://support.3com.com/registration/frontpg.pl>

Documentation Feedback

Your suggestions are very important to us. They will help make our documentation more useful to you. Please e-mail comments about this document to 3Com at:

pddtechpubs_comments@3Com.com

Please include the following information when commenting: the document title, part number (shown at the bottom of this page), and page number, if appropriate.