



# 10-Port 100BASE-FX and 20-Port 10/100BASE-TX Fast Ethernet Layer 2 Switching Modules Quick Start Guide

For the CoreBuilder® 9000 Enterprise Switch

## Module Descriptions

This guide describes key installation information for two CoreBuilder® 9000 Fast Ethernet (FEN) Switching Modules:

- The 10-port 100BASE-FX Fast Ethernet Layer 2 Switching Module (Model Number 3CB9LF10MC) has ten 100 Mbps Ethernet fiber-optic ports with SC connectors on its front panel and two 1-Gigabit ports on the back for connection to the chassis backplane.
- The 20-port 10/100BASE-TX Fast Ethernet Layer 2 Switching Module (Model Number 3CB9LF20R) has twenty 10/100 Mbps RJ-45 ports on its front panel and two 1-Gigabit ports on the back for connection to the chassis backplane.

Each of these FEN Switching Modules operates as a Layer 2 switch and occupies a single switching module slot in the CoreBuilder 9000 7-slot chassis, 8-slot chassis, or 16-slot chassis.

## Key Features

The 10/100BASE-TX and 100BASE-FX FEN Switching Modules support the following key features:

- Hot-swapping of modules
- Management using the Administration Console (a command line interface), the Web Management suite of applications with an Internet browser, or SNMP-based applications

For information about the software features that these modules support, see the:

- *CoreBuilder 9000 Implementation Guide*
- *Command Reference Guide*
- *CoreBuilder 9000 Release Notes for the Fast Ethernet and Gigabit Ethernet Layer 2 Switching Modules*

**Front Panel** On the 10-port 100BASE-FX FEN Switching Module, the front panel ports are numbered 1 through 10, as shown in Figure 1. The two 1-Gigabit ports on the back of the module (not shown in Figure 1) are numbered 11 and 12.

On the 20-port 10/100BASE-TX FEN Switching Module, the front panel ports are numbered 1 through 20, as shown in Figure 1. The two 1-Gigabit ports on the back of the module (not shown in Figure 1) are numbered 21 and 22.

**Figure 1** Front Panels for the 10/100BASE-TX and 100BASE-FX FEN Modules

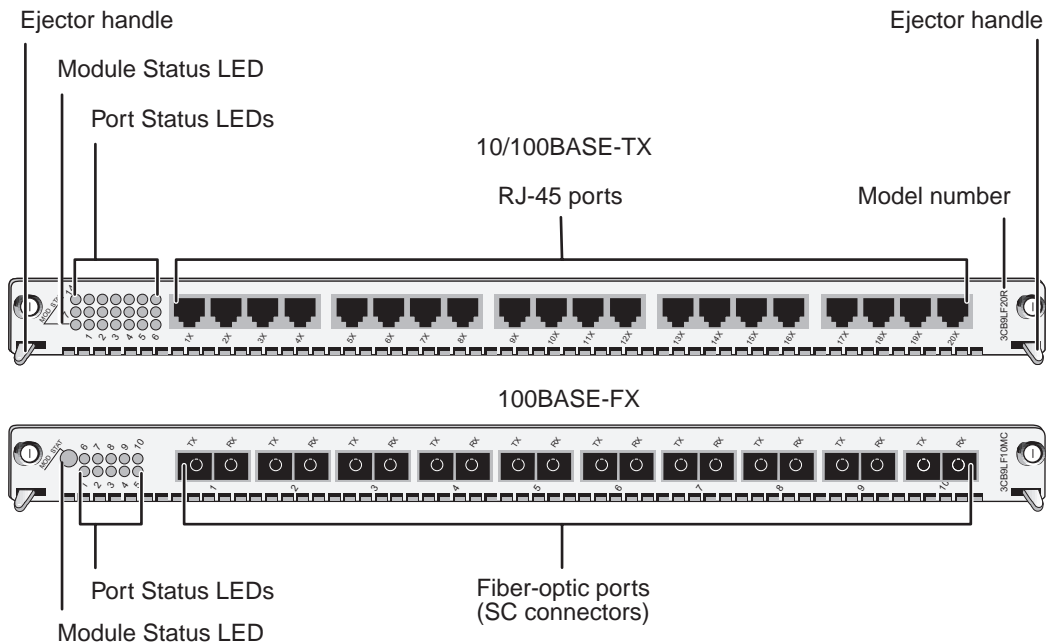

In the 7-slot chassis, you install the modules horizontally with the LEDs at the left. In the 8-slot chassis and the 16-slot chassis, you install the modules vertically with the LEDs at the top.

**Audience Description** This guide is intended for *trained technical personnel* only. Do not attempt to install, remove, or replace the 10/100BASE-TX or 100BASE-FX FEN Switching Modules if you have not had the proper training from 3Com. For training information in the United States and Canada, call 1-800-NET-3COM. For the numbers to call in other locations, visit the 3Com Web site:

[www.3Com.com/support/](http://www.3Com.com/support/)

**Safety Precautions** When you handle components in a CoreBuilder 9000 system, be sure that you follow all safety precautions. To avoid electric shocks, burns, or equipment damage, read and follow these warnings:

**WARNING:** Allow only trained service personnel to install, remove, or replace any module in the chassis.



**WARNING:** Hazardous energy exists within the system. Use extreme caution when you install, remove, or replace any module in the chassis. When the system is on:

- Never insert metal objects such as a screwdriver or a finger with jewelry into open module slots.
- Do not touch any connections within the chassis with your hands or fingers.



**WARNING:** To ensure optical safety when installing a FEN Switching Module, comply with the following precaution:

Although the data communication LEDs used in this product meet the regulatory requirements for casual exposure to the eye, as with any source of bright light, it is advised that you do not look into the light source.

**LED Safety Information:** IEC 825 and EN60825, Class 1 LED Device. For connection only to Class 1 LED Devices.

CLASS 1  
LED PRODUCT

### ESD Safety Information

Electrostatic discharge (ESD) can damage components of the module. ESD, which occurs when a module is improperly handled, can cause complete or intermittent failures.



**CAUTION:** *To prevent ESD-related damage:*

- *Always wear an ESD wrist strap (not provided) when you handle a module, ensuring that the strap makes good skin contact and is properly grounded.*
- *Keep the module in its antistatic bag until you are ready to install it.*

### Handling Precautions

When you handle a module, follow these precautions:

- Always handle the module by the front panel only.
- Do not touch the components, pins, leads, or solder connections.
- Do not twist or otherwise force the module into the chassis when you insert it into the module guides.
- Before you push the module into the chassis, verify that the module ejector handles are open.
- When you slide the module into the 7-slot chassis, match the left and right module guides. In the 8-slot chassis or 16-slot chassis, match the upper and lower module guides.

For details, see “Installation Prerequisites” and “Installing the Module” later in this guide.

## Unpacking Instructions

Use the following procedure when you unpack a FEN Switching Module:

- 1 Verify that the module is the correct product by matching the 3C number that is listed on the shipping box label to the 3C number that you ordered (Model Number 3CB9LF10MC for the 10-port 100BASE-FX Fast Ethernet Layer 2 Switching Module or Model Number 3CB9LF20R for the 20-port 10/100BASE-TX Fast Ethernet Layer 2 Switching Module).
- 2 Remove the module, in its antistatic bag, from the shipping box.
- 3 Observing the caution instructions, remove the module from its antistatic bag and inspect it for physical damage.



**CAUTION:** Handle the module only by the front panel. Do not touch any components, pins, leads, or solder connections.

If the module appears to be damaged, replace it in the antistatic bag, put it back in the shipping box, and contact your network supplier.

- 4 Verify that the box also contains:
  - *CoreBuilder 9000 Release Notes for the Fast Ethernet and Gigabit Ethernet Layer 2 Switching Modules*
  - *10-Port 100BASE-FX and 20-Port 10/100BASE-TX Fast Ethernet Layer 2 Switching Modules Quick Start Guide for the CoreBuilder 9000 Enterprise Switch* (this guide)

If the listed contents are not in your shipping box, contact your network supplier.



*All shipping boxes are reusable. After you remove the contents, replace the packing materials in the box and store it for future use.*

## Installation Prerequisites

Before you install a module, make the following preparations:

- Verify that the chassis is properly installed in a rack, on a table, or on a shelf, according to the instructions in either of these guides:
  - *7-Slot Chassis Quick Installation Guide for the CoreBuilder 9000 Enterprise Switch*
  - *Chassis Quick Installation Guide for the CoreBuilder 9000 Enterprise Switch 8-slot Chassis and 16-slot Chassis.*
- Have a flat-blade torque screwdriver available to secure the module to the chassis after you install it.
- Read the *CoreBuilder 9000 Release Notes for the Fast Ethernet and Gigabit Ethernet Layer 2 Switching Modules* for important information about installing and upgrading modules in an existing chassis or a new chassis.



**CAUTION:** All modules in a CoreBuilder 9000 chassis must operate at compatible software levels. You must verify the software release on all new and existing modules in your chassis and upgrade as necessary. See the CoreBuilder 9000 Release Notes for the Fast Ethernet and Gigabit Ethernet Layer 2 Switching Modules for a module software compatibility requirements table, mandatory upgrade procedures, and other important information.

## Module Placement in the Chassis

Note the following chassis slot restrictions and recommendations when you choose a chassis slot for the 10-port 100BASE-FX Fast Ethernet Switching Module or the 20-port 10/100BASE-TX Fast Ethernet Switching Module:

- In the 7-slot chassis:
  - Do not install the module in slot 7. This slot is reserved for a Gigabit Ethernet (GEN) Switch Fabric Module.
  - Install the module in slot 1, 2, 3, 4, 5, or 6.
- In the 8-slot chassis:
  - Do not install the module in slot 7 or slot 8. These slots are reserved for GEN Switch Fabric Modules.
  - Install the FEN Switching Module in slot 1, 2, 3, 4, 5, or 6.

- In the 16-slot chassis:
  - Do not install the module in slot 8 or slot 9. These slots are reserved for GEN Switch Fabric Modules.
  - Install the module in slot 1, 2, 3, 4, 5, 6, 7, 10, 11, or 12.
  - 3Com recommends that you do not install the module in slot 13, 14, 15, or 16 because these slots have only one connection to the GEN Switch Fabric Module.
- Table 1, Table 2, and Table 3 list the relationship between the following:
  - 24-port GEN Switch Fabric Module (SFM) (Model Number 3CB9FG24 or Model Number 3CB9FG24T)
  - 10-port 100BASE-FX FEN Switching Module
- Switching module slots in the 7-slot chassis, 8-slot chassis, and 16-slot chassis, respectively

Table 4, Table 5, and Table 6 list the relationship between the following:

- 24-port GEN Switch Fabric Module (SFM)
- 20-port 10/100BASE-TX FEN Switching Module
- Switching module slots in the 7-slot chassis, 8-slot chassis, and 16-slot chassis, respectively

Table 7 and Table 8 list the relationship between the following:

- 9-port GEN Switch Fabric Module (SFM) (Model Number 3CB9FG9)
- 10-port 100BASE-FX FEN Switching Module
- Switching module slots in the 7-slot chassis and 8-slot chassis, respectively

Table 9 and Table 10 list the relationship between the following:

- 9-port GEN Switch Fabric Module (SFM)
- 20-port 10/100BASE-TX FEN Switching Module
- Switching module slots in the 7-slot chassis and 8-slot chassis, respectively

Use the table information to help select a slot for your module, as well as administer the system after you have completed the installation.

**Table 1** Mapping the 24-port GEN SFM and the 10-port FEN Switching Module to the 7-slot Chassis

<b>Chassis Slot Number</b>	<b>Number of SFM Backplane Ports Allocated to Slot</b>	<b>10-port Switching Module Backplane Port Numbers</b>	<b>SFM Backplane Port Numbers Assigned to Chassis Slot</b>	<b>SFM LED Numbers Assigned to Backplane Port Numbers</b>
1	4; up to 2 can be accessed by this module	11 12	1 2	1 2
2	4; up to 2 can be accessed by this module	11 12	5 6	3 4
3	4; up to 2 can be accessed by this module	11 12	9 10	5 6
4	4; up to 2 can be accessed by this module	11 12	13 14	7 8
5	4; up to 2 can be accessed by this module	11 12	17 18	9 10
6	4; up to 2 can be accessed by this module	11 12	21 22	11 12
7	Reserved for an SFM	Not applicable	Not applicable	Not applicable



**Table 2** Mapping the 24-port GEN SFM and the 10-port FEN Switching Module to the 8-slot Chassis

<b>Chassis Slot Number</b>	<b>Number of SFM Backplane Ports Allocated to Slot</b>	<b>10-port Switching Module Backplane Port Numbers</b>	<b>SFM Backplane Port Numbers Assigned to Chassis Slot</b>	<b>SFM LED Numbers Assigned to Backplane Port Numbers</b>
1	4; up to 2 can be accessed by this module	11 12	1 2	1 2
2	4; up to 2 can be accessed by this module	11 12	5 6	3 4
3	4; up to 2 can be accessed by this module	11 12	9 10	5 6
4	4; up to 2 can be accessed by this module	11 12	13 14	7 8
5	4; up to 2 can be accessed by this module	11 12	17 18	9 10
6	4; up to 2 can be accessed by this module	11 12	21 22	11 12
7	Reserved for an SFM	Not applicable	Not applicable	Not applicable
8	Reserved for an SFM	Not applicable	Not applicable	Not applicable

**Table 3** Mapping the 24-port GEN SFM and the 10-port FEN Switching Module to the 16-slot Chassis

Chassis Slot Number	Number of SFM Backplane Ports Allocated to Slot	10-port Switching Module Backplane Port Numbers	SFM Backplane Port Numbers Assigned to Chassis Slot	SFM LED Numbers Assigned to Backplane Port Numbers
1	2	11	1	1
		12	2	2
2	2	11	3	3
		12	4	4
3	2	11	5	5
		12	6	6
4	2	11	7	7
		12	8	8
5	2	11	9	9
		12	10	10
6	2	11	11	11
		12	12	12
7	2	11	13	13
		12	14	14
8	Reserved for an SFM	Not applicable	Not applicable	Not applicable
9	Reserved for an SFM	Not applicable	Not applicable	Not applicable
10	2	11	15	15
		12	16	16
11	2	11	17	17
		12	18	18
12	2	11	19	19
		12	20	20
13	1	11	21	21
14	1	11	22	22
15	1	11	23	23
16	1	11	24	24

**Table 4** Mapping the 24-port GEN SFM and the 20-port FEN Switching Module to the 7-slot Chassis

<b>Chassis Slot Number</b>	<b>Number of SFM Backplane Ports Allocated to Slot</b>	<b>20-port Switching Module Backplane Port Numbers</b>	<b>SFM Backplane Port Numbers Assigned to Chassis Slot</b>	<b>SFM LED Numbers Assigned to Backplane Port Numbers</b>
1	4; up to 2 can be accessed by this module	21 22	1 2	1 2
2	4; up to 2 can be accessed by this module	21 22	5 6	3 4
3	4; up to 2 can be accessed by this module	21 22	9 10	5 6
4	4; up to 2 can be accessed by this module	21 22	13 14	7 8
5	4; up to 2 can be accessed by this module	21 22	17 18	9 10
6	4; up to 2 can be accessed by this module	21 22	21 22	11 12
7	Reserved for an SFM	Not applicable	Not applicable	Not applicable

**Table 5** Mapping the 24-port GEN SFM and the 20-port FEN Switching Module to the 8-slot Chassis

<b>Chassis Slot Number</b>	<b>Number of SFM Backplane Ports Allocated to Slot</b>	<b>20-port Switching Module Backplane Port Numbers</b>	<b>SFM Backplane Port Numbers Assigned to Chassis Slot</b>	<b>SFM LED Numbers Assigned to Backplane Port Numbers</b>
1	4; up to 2 can be accessed by this module	21 22	1 2	1 2
2	4; up to 2 can be accessed by this module	21 22	5 6	3 4
3	4; up to 2 can be accessed by this module	21 22	9 10	5 6
4	4; up to 2 can be accessed by this module	21 22	13 14	7 8
5	4; up to 2 can be accessed by this module	21 22	17 18	9 10
6	4; up to 2 can be accessed by this module	21 22	21 22	11 12
7	Reserved for an SFM	Not applicable	Not applicable	Not applicable
8	Reserved for an SFM	Not applicable	Not applicable	Not applicable

**Table 6** Mapping the 24-port GEN SFM and the 20-port FEN Switching Module to the 16-slot Chassis

Chassis Slot Number	Number of SFM Backplane Ports Allocated to Slot	20-port Switching Module Backplane Port Numbers	SFM Backplane Port Numbers Assigned to Chassis Slot	SFM LED Numbers Assigned to Backplane Port Numbers
1	2	21	1	1
		22	2	2
2	2	21	3	3
		22	4	4
3	2	21	5	5
		22	6	6
4	2	21	7	7
		22	8	8
5	2	21	9	9
		22	10	10
6	2	21	11	11
		22	12	12
7	2	21	13	13
		22	14	14
8	Reserved for an SFM	Not applicable	Not applicable	Not applicable
9	Reserved for an SFM	Not applicable	Not applicable	Not applicable
10	2	21	15	15
		22	16	16
11	2	21	17	17
		22	18	18
12	2	21	19	19
		22	20	20
13	1	21	21	21
14	1	21	22	22
15	1	21	23	23
16	1	21	24	24

**Table 7** Mapping the 9-port GEN SFM and the 10-port FEN Switching Module to the 7-slot Chassis

Chassis Slot Number	Number of SFM Backplane Ports Allocated to Slot	10-port Switching Module Backplane Port Numbers	SFM Backplane Port Numbers Assigned to Chassis Slot	SFM LED Numbers Assigned to Backplane Port Numbers
1	1	11	1	1
2	1	11	2	2
3	1	11	3	3
4	1	11	4	4
5	1	11	5	5
6	1	11	6	6
7	Reserved for an SFM	Not applicable	Not applicable	Not applicable

**Table 8** Mapping the 9-port GEN SFM and the 10-port FEN Switching Module to the 8-slot Chassis

Chassis Slot Number	Number of SFM Backplane Ports Allocated to Slot	10-port Switching Module Backplane Port Numbers	SFM Backplane Port Numbers Assigned to Chassis Slot	SFM LED Numbers Assigned to Backplane Port Numbers
1	1	11	1	1
2	1	11	2	2
3	1	11	3	3
4	1	11	4	4
5	1	11	5	5
6	1	11	6	6
7	Reserved for an SFM	Not applicable	Not applicable	Not applicable
8	Reserved for an SFM	Not applicable	Not applicable	Not applicable

**Table 9** Mapping the 9-port GEN SFM and the 20-port FEN Switching Module to in the 7-slot Chassis

Chassis Slot Number	Number of SFM Backplane Ports Allocated to Slot	20-port Switching Module Backplane Port Numbers	SFM Backplane Port Numbers Assigned to Chassis Slot	SFM LED Numbers Assigned to Backplane Port Numbers
1	1	21	1	1
2	1	21	2	2
3	1	21	3	3
4	1	21	4	4
5	1	21	5	5
6	1	21	6	6
7	Reserved for an SFM	Not applicable	Not applicable	Not applicable

**Table 10** Mapping the 9-port GEN SFM and the 20-port FEN Switching Module to the 8-slot Chassis

Chassis Slot Number	Number of SFM Backplane Ports Allocated to Slot	20-port Switching Module Backplane Port Numbers	SFM Backplane Port Numbers Assigned to Chassis Slot	SFM LED Numbers Assigned to Backplane Port Numbers
1	1	21	1	1
2	1	21	2	2
3	1	21	3	3
4	1	21	4	4
5	1	21	5	5
6	1	21	6	6
7	Reserved for an SFM	Not applicable	Not applicable	Not applicable
8	Reserved for an SFM	Not applicable	Not applicable	Not applicable

## Installing the Module

To install a FEN Switching Module:

- 1 Before you start the installation process, read and follow the instructions in “Safety Precautions,” “Handling Precautions,” and “Installation Prerequisites” earlier in this guide.
- 2 Select a chassis slot for your module, following the restrictions and recommendations in “Module Placement in the Chassis” earlier in this guide.
- 3 To expose a slot for the module, remove the blank faceplate.

Save this faceplate in case you need it in the future. Empty slots must be covered to ensure proper airflow and cooling in the chassis.



*3Com recommends that you remove the faceplate only for the slot where you intend to install an individual module; leave the remaining faceplates in the chassis.*

- 4 Open the module ejector handles.
- 5 Begin to insert the module:
  - In the 7-slot chassis, hold the module horizontally with the LEDs to the left and begin to insert the module using the guides on the left and the right of the slot. Figure 2 shows the module position in a 7-slot chassis.
  - In the 8-slot chassis and 16-slot chassis, hold the module vertically with the LEDs at the top and begin to insert the module using the guides on the top and the bottom of the slot. Figure 3 shows the module position in a 16-slot chassis. The module position is the same in an 8-slot chassis.



**CAUTION:** *Do not twist or bend the module when you insert it.*

- 6 Slide the module into the chassis by pushing firmly on the two ends of the front panel near the ejector handles.



**WARNING:** *Hazardous energy exists inside the chassis. Do not place hands or objects into the chassis or touch any components on an inserted module.*



**Figure 2** Installing a FEN Switching Module into a 7-Slot Chassis

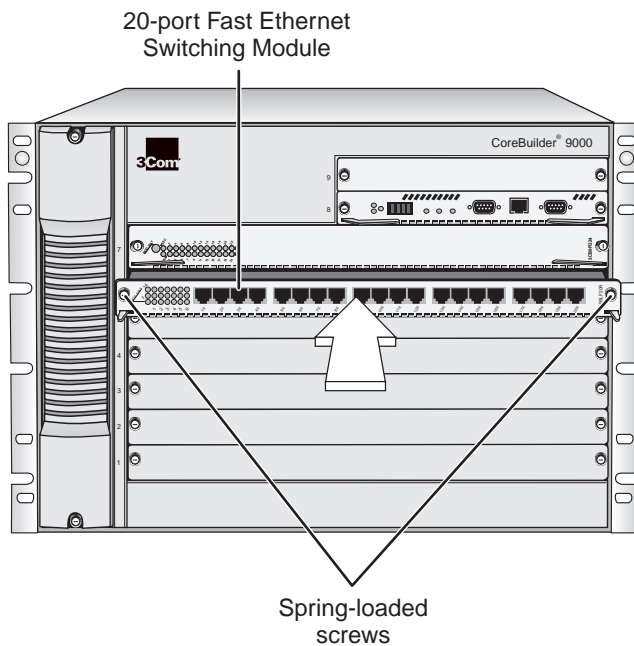

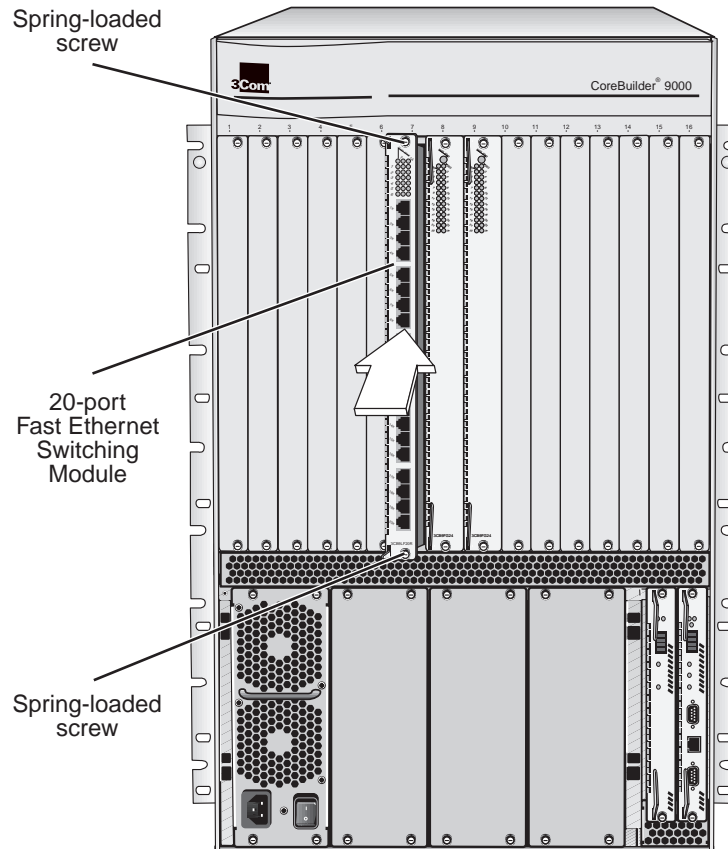
**Figure 3** Installing a FEN Switching Module into a 16-Slot Chassis

- 7 To engage the module with the backplane, use both hands to perform the following steps:
  - a Push firmly at the two ends of the front panel near the ejector handles until you feel the module connectors make firm contact with the backplane connectors.
  - b Put your left thumb on the left or top ejector handle and your right thumb on the right or bottom ejector handle. Simultaneously, push the ejector handles in towards the front panel until each handle is parallel with the front panel.

You feel a slight resistance as the connectors fully engage.



**CAUTION:** *If there is too much resistance when you try to close the ejector handles, the module backplane connector may not be aligned. Forcing the module into place can damage the module connectors and backplane connectors. If necessary, remove and reinsert the module, ensuring that the connectors are properly aligned. Do not tighten the spring-loaded screws to seat the module.*

- 8 To secure the module in the chassis, tighten the spring-loaded screws to a torque specification of 3 to 5 inch-pounds.



**CAUTION:** *Verify that the module screws are properly aligned with the threaded holes in the chassis. If the screws are not aligned when you tighten them, you may strip the threads and make it impossible to secure the module.*



*To ensure that you tighten screws to torque specification, use a torque screwdriver.*



**WARNING:** *To ensure adequate cooling airflow and continued product safety agency compliance, install blank faceplates over all empty slots.*

If the chassis is powered on, the module initialization process begins.

## Verifying Module Operation

The 10-port 100BASE-FX FEN Switching Module has 10 Port Status LEDs and the 20-port 10/100BASE-TX FEN Switching Module has 20 Port Status LEDs. Each module has one Module Status LED.

Watch the LEDs during the system power-on diagnostics test to verify proper module operation:

- On the Module Status LED, the normal power-on test sequence is Green – Yellow – Green – Flashing Green (while running the diagnostic test) – Green



*If the Module Status LED is Yellow after the diagnostics run, the module has failed.*

- The Port Status LEDs are tested during the diagnostic test. The normal test sequence is Yellow – Green – Off

Table 11 describes LED colors and definitions.

**Table 11** Module and Port Status LED Indicators

LED	State or Color	Definition
<b>Module Status</b>	Green	Power is on (normal operation).
	Flashing Green	Diagnostics or software download is in progress.
	Yellow	Diagnostic failure.
	Off	After initial insertion or module reset, the LED remains unlit for approximately 3 seconds. Otherwise, an unlit LED indicates that the module is not receiving power.
<b>Port Status</b>	Green	Port is enabled and link is up.
	Flashing Green	Port is receiving or transmitting packets.
	Yellow	Module or port is malfunctioning.
	Off	Port is disabled or link is down.

## Managing the Module

You configure and manage a FEN Switching Module using several interfaces. The following sections describe two of the interfaces.

### Administration Console

The Administration Console is the embedded menu-driven command line interface that you access from a terminal or through terminal emulation software.

To manage the module from the Administration Console:

- 1 Log in to the EME.

For information about how to log in to the EME, see the *CoreBuilder 9000 Enterprise Management Engine User Guide*.

- 2 At the EME prompt, enter:

```
connect <slot>.1
```

where <slot> is the chassis slot number of the module that you want to manage, and the number after the decimal point is a subslot number, which is always 1.

The top level of the Administration Console menu for the module appears.

- 3 Enter command strings to manage the module. For example, to display a module baseline, enter:

```
module baseline display
```

For information about the Administration Console module commands, see the *Command Reference Guide*.

### Web Management

Web Management applications are an embedded part of the system. They include WebConsole, DeviceView, and Performance monitoring tools. Additional installable applications include online Help.

After you have set up the IP address for your system, you can access the Web Management applications directly in your Web browser by entering the IP address.

For information about setting up your IP address, see the *Enterprise Management Engine Quick Start Guide for the CoreBuilder 9000 Enterprise Switch*. For additional information about Web Management, see the *Web Management User Guide for the CoreBuilder 9000 Enterprise Switch*.

**Module Specifications** The following tables list specifications for the 10-port 100BASE-FX and 20-port 10/100BASE-TX Fast Ethernet Layer 2 Switching Modules:

### Cabling Requirements

Module	Required Cable Type	Maximum Segment Length
100BASE-FX (3CB9LF10MC)	Multimode fiber 62.5/125 micron	Half-duplex mode: 400 m (1312 ft) Full-duplex mode: 2 km (1.2 mi)
10/100BASE-TX (3CB9LF20R)	UTP Category 5	Up to 100 m (328 ft)

### Environmental Requirements

Operating temperature	0 to 50 °C (32 to 122 °F)
Operating humidity	10% to 90% relative humidity, noncondensing
Storage temperature	−40 to 66 °C (−40 to 151 °F)
Storage humidity	5% to 95% relative humidity, noncondensing

### Physical Specifications

Module	Dimensions	Weight
100BASE-FX (3CB9LF10MC)	25.4 mm x 340.36 mm x 388.112 mm (1 in. x 13.4 in. x 15.28 in.)	1.135 kg (2.5 lb)
10/100BASE-TX (3CB9LF20R)	25.4 mm x 340.36 mm x 388.112 mm (1 in. x 13.4 in. x 15.28 in.)	1.1804 kg (2.6 lb)

### Power Specifications

Module	Voltage	Wattage
100BASE-FX (3CB9LF10MC)	+5.2 V	25 W
	+3.5 V	33 W
	+12 V	2 W
	<b>Total Wattage = 60</b>	
10/100BASE-TX (3CB9LF20R)	+5.2 V	28 W
	+3.5 V	41 W
	+12 V	2 W
	<b>Total Wattage = 71</b>	

## Regulatory Compliance

### Safety

- CSA 22.2 No. 950
- EN 60950
- IEC 60950 (formerly IEC 950)
- UL 1950
- EN 60825 -1, -2
- CE Mark

### Emissions

- FCC Part 15 Class A
- ICES003 Class A
- VCCI Class A
- EN 55022 Class A
- EN 50082-1
- AS3548 (C-Tick Mark)
- CISPR 22 Class A
- CE Mark

### Related CoreBuilder 9000 Documents

For detailed information about using and managing the FEN Switching Modules, see the following documents:

- *CoreBuilder 9000 Implementation Guide*
- *Command Reference Guide*
- *CoreBuilder 9000 Enterprise Management Engine User Guide*
- *Web Management User Guide for the CoreBuilder 9000 Enterprise Switch*

For the software code installation procedure as well as known problem information for this module, see the *CoreBuilder 9000 Release Notes for the Fast Ethernet and Gigabit Ethernet Layer 2 Switching Modules*.

For information about installing and powering on the system, see the following documents:

- *CoreBuilder 9000 Enterprise Switch Getting Started Guide*
- *7-Slot Chassis Quick Installation Guide for the CoreBuilder 9000 Enterprise Switch*
- *Chassis Quick Installation Guide for the CoreBuilder 9000 Enterprise Switch 8-slot Chassis and 16-slot Chassis*
- *7-Slot Chassis Power Supply Installation Guide for the CoreBuilder 9000 Enterprise Switch*
- *Power Supply Installation Guide for the CoreBuilder 9000 Enterprise Switch 8-slot Chassis and 16-slot Chassis*

You can view and print these and other current CoreBuilder 9000 documents from the following sources:

- 3Com Web site

**<http://support.3com.com/nav/switches.htm>**

- *CoreBuilder 9000 Documentation CD-ROM*

This CD-ROM is included in the chassis shipping box. You can also order the CD-ROM separately (Order Number 3CB9DB).



# 3Com Corporation LIMITED WARRANTY

## 10-Port 100BASE-FX Fast Ethernet Layer 2 Switching Module (Model Number 3CB9LF10MC) and 20-Port 10/100BASE-TX Fast Ethernet Layer 2 Switching Module (Model Number 3CB9LF20R) for the CoreBuilder® 9000 Enterprise Switch

---

### HARDWARE

3Com warrants to the end user ("Customer") that this hardware product will be free from defects in workmanship and materials, under normal use and service, for one (1) year from the date of purchase from 3Com or its authorized reseller.

3Com's sole obligation under this express warranty shall be, at 3Com's option and expense, to repair the defective product or part, deliver to Customer an equivalent product or part to replace the defective item, or if neither of the two foregoing options is reasonably available, 3Com may, in its sole discretion, refund to Customer the purchase price paid for the defective product. All products that are replaced will become the property of 3Com. Replacement products may be new or reconditioned. 3Com warrants any replaced or repaired product or part for ninety (90) days from shipment, or the remainder of the initial warranty period, whichever is longer.

---

### SOFTWARE

3Com warrants to Customer that each software program licensed from it will perform in substantial conformance to its program specifications, for a period of ninety (90) days from the date of purchase from 3Com or its authorized reseller. 3Com warrants the media containing software against failure during the warranty period. No updates are provided. 3Com's sole obligation under this express warranty shall be, at 3Com's option and expense, to refund the purchase price paid by Customer for any defective software product, or to replace any defective media with software which substantially conforms to applicable 3Com published specifications. Customer assumes responsibility for the selection of the appropriate applications program and associated reference materials. 3Com makes no warranty or representation that its software products will meet Customer's requirements or work in combination with any hardware or applications software products provided by third parties, that the operation of the software products will be uninterrupted or error free, or that all defects in the software products will be corrected. For any third-party products listed in the 3Com software product documentation or specifications as being compatible, 3Com will make reasonable efforts to provide compatibility, except where the noncompatibility is caused by a "bug" or defect in the third party's product or from use of the software product not in accordance with 3Com's published specifications or user manual.

THIS 3COM PRODUCT MAY INCLUDE OR BE BUNDLED WITH THIRD-PARTY SOFTWARE, THE USE OF WHICH IS GOVERNED BY A SEPARATE END-USER LICENSE AGREEMENT. THIS 3COM WARRANTY DOES NOT APPLY TO SUCH THIRD-PARTY SOFTWARE. FOR THE APPLICABLE WARRANTY, PLEASE REFER TO THE END-USER LICENSE AGREEMENT GOVERNING THE USE OF SUCH SOFTWARE.

---

### YEAR 2000 WARRANTY

In addition to the Hardware Warranty and Software Warranty stated above, 3Com warrants that each product sold or licensed to Customer on and after January 1, 1998, that is date sensitive will continue performing properly with regard to such date data on and after January 1, 2000, provided that all other products used by Customer in connection or combination with the 3Com product, including hardware, software, and firmware, accurately exchange date data with the 3Com product, with the exception of those products identified at 3Com's Web site, <http://www.3com.com/products/yr2000.html>, as not meeting this standard. If it appears that any product that is stated to meet this standard does not perform properly with regard to such date data on and after January 1, 2000, and Customer notifies 3Com before the later of April 1, 2000, or ninety (90) days after purchase of the product from 3Com or its authorized reseller, 3Com shall, at its option and expense, provide a software update which would effect the proper performance of such product, repair such product, deliver to Customer an equivalent product to replace such product, or, if none of the foregoing is feasible, refund to Customer the purchase price paid for such product.

Any software update or replaced or repaired product will carry a Year 2000 Warranty for ninety (90) days after purchase or until April 1, 2000, whichever is later.

---

### OBTAINING WARRANTY SERVICE

Customer must contact a 3Com Corporate Service Center or an Authorized 3Com Service Center within the applicable warranty period to obtain warranty service authorization. Dated proof of purchase from 3Com or its authorized reseller may be required. Products returned to 3Com's Corporate Service Center must be preauthorized by 3Com with a Return Material Authorization (RMA) number or User Service Order (USO) number marked on the outside of the package, and sent prepaid and packaged appropriately for safe shipment, and it is recommended that they be insured or sent by a method that provides for tracking of the package. Responsibility for loss or damage does not transfer to 3Com until the returned item is received by 3Com. The repaired or replaced item will be shipped to Customer, at 3Com's expense, not later than thirty (30) days after 3Com receives the defective product.

3Com shall not be responsible for any software, firmware, information, or memory data of Customer contained in, stored on, or integrated with any products returned to 3Com for repair, whether under warranty or not.

*Dead- or Defective-on-Arrival.* In the event a product completely fails to function or exhibits a defect in materials or workmanship within the first forty-eight (48) hours of installation but no later than thirty (30) days after the date of purchase, and this is verified by 3Com, it will be considered dead- or defective-on-arrival (DOA) and a replacement shall be provided by advance replacement. The replacement product will normally be shipped not later than three (3) business days after 3Com's verification of the DOA product, but may be delayed due to export or import procedures. The shipment of advance replacement products is subject to local legal requirements and may not be available in all locations. When an advance replacement is provided and Customer fails to return the original product to 3Com within fifteen (15) days after shipment of the replacement, 3Com will charge Customer for the replacement product, at list price.

*Advance Replacement* is provided for ninety (90) days, after which time it may be available for a specified fee. 3Com will make commercially reasonable efforts to ship the replacement product not later than five (5) business days after receiving the request for advance replacement, but may be delayed due to product availability or export or import procedures. The shipment of advance replacement products is subject to local legal requirements and may not be available in all locations. When an advance replacement is provided and Customer fails to return the original product to 3Com within fifteen (15) days after shipment of the replacement, 3Com will charge Customer for the replacement, at list price. This advance replacement is different from the fee-based Advance Hardware Replacement Service, which is available as a contracted service offering.

**INCLUDED SERVICES:**

*Telephone Support*, with coverage for basic troubleshooting only, will be provided for ninety (90) days from the date of purchase, on a commercially reasonable efforts basis. Please refer to the Technical Support appendix in the Getting Started Guide for telephone numbers.

*3Com's Web and Bulletin Board Services* provide 3Knowledgebase, bug tracking, documentation, release notes, and some software maintenance releases at no charge.

---

**WARRANTIES EXCLUSIVE**

IF A 3COM PRODUCT DOES NOT OPERATE AS WARRANTED ABOVE, CUSTOMER'S SOLE REMEDY FOR BREACH OF THAT WARRANTY SHALL BE REPAIR, REPLACEMENT, OR REFUND OF THE PURCHASE PRICE PAID, AT 3COM'S OPTION. TO THE FULL EXTENT ALLOWED BY LAW, THE FOREGOING WARRANTIES AND REMEDIES ARE EXCLUSIVE AND ARE IN LIEU OF ALL OTHER WARRANTIES, TERMS, OR CONDITIONS, EXPRESS OR IMPLIED, EITHER IN FACT OR BY OPERATION OF LAW, STATUTORY OR OTHERWISE, INCLUDING WARRANTIES, TERMS, OR CONDITIONS OF MERCHANTABILITY, FITNESS FOR A PARTICULAR PURPOSE, SATISFACTORY QUALITY, CORRESPONDENCE WITH DESCRIPTION, AND NONINFRINGEMENT, ALL OF WHICH ARE EXPRESSLY DISCLAIMED. 3COM NEITHER ASSUMES NOR AUTHORIZES ANY OTHER PERSON TO ASSUME FOR IT ANY OTHER LIABILITY IN CONNECTION WITH THE SALE, INSTALLATION, MAINTENANCE, OR USE OF ITS PRODUCTS.

3COM SHALL NOT BE LIABLE UNDER THIS WARRANTY IF ITS TESTING AND EXAMINATION DISCLOSE THAT THE ALLEGED DEFECT OR MALFUNCTION IN THE PRODUCT DOES NOT EXIST OR WAS CAUSED BY CUSTOMER'S OR ANY THIRD PERSON'S MISUSE, NEGLIGENCE, IMPROPER INSTALLATION OR TESTING, UNAUTHORIZED ATTEMPTS TO OPEN, REPAIR, OR MODIFY THE PRODUCT, OR ANY OTHER CAUSE BEYOND THE RANGE OF THE INTENDED USE, OR BY ACCIDENT, FIRE, LIGHTNING, POWER CUTS OR OUTAGES, OTHER HAZARDS, OR ACTS OF GOD.

---

**LIMITATION OF LIABILITY**

TO THE FULL EXTENT ALLOWED BY LAW, 3COM ALSO EXCLUDES FOR ITSELF AND ITS SUPPLIERS ANY LIABILITY, WHETHER BASED IN CONTRACT OR TORT (INCLUDING NEGLIGENCE), FOR INCIDENTAL, CONSEQUENTIAL, INDIRECT, SPECIAL, OR PUNITIVE DAMAGES OF ANY KIND, OR FOR LOSS OF REVENUE OR PROFITS, LOSS OF BUSINESS, LOSS OF INFORMATION OR DATA, OR OTHER FINANCIAL LOSS ARISING OUT OF OR IN CONNECTION WITH THE SALE, INSTALLATION, MAINTENANCE, USE, PERFORMANCE, FAILURE, OR INTERRUPTION OF ITS PRODUCTS, EVEN IF 3COM OR ITS AUTHORIZED RESELLER HAS BEEN ADVISED OF THE POSSIBILITY OF SUCH DAMAGES, AND LIMITS ITS LIABILITY TO REPAIR, REPLACEMENT, OR REFUND OF THE PURCHASE PRICE PAID, AT 3COM'S OPTION. THIS DISCLAIMER OF LIABILITY FOR DAMAGES WILL NOT BE AFFECTED IF ANY REMEDY PROVIDED HEREIN SHALL FAIL OF ITS ESSENTIAL PURPOSE.

---

**DISCLAIMER**

Some countries, states, or provinces do not allow the exclusion or limitation of implied warranties or the limitation of incidental or consequential damages for certain products supplied to consumers, or the limitation of liability for personal injury, so the above limitations and exclusions may be limited in their application to you. When the implied warranties are not allowed to be excluded in their entirety, they will be limited to the duration of the applicable written warranty. This warranty gives you specific legal rights which may vary depending on local law.

---

**GOVERNING LAW**

This Limited Warranty shall be governed by the laws of the State of California, U.S.A., excluding its conflicts of laws principles and excluding the United Nations Convention on Contracts for the International Sale of Goods.

**3Com Corporation**, 5400 Bayfront Plaza, P.O. Box 58145, Santa Clara, CA 95052-8145 (408) 326-5000

---

## EMISSIONS COMPLIANCE STATEMENTS FOR CLASS A PRODUCTS

- Federal Communications Commission Notice This equipment has been tested and found to comply with the limits for a Class A digital device, pursuant to part 15 of the FCC rules. These limits are designed to provide reasonable protection against harmful interference when the equipment is operated in a commercial environment. This equipment generates, uses, and can radiate radio frequency energy and, if not installed and used in accordance with the instruction manual, may cause harmful interference to radio communications. Operation of this equipment in a residential area is likely to cause harmful interference, in which case the user will be required to correct the interference at his or her own expense.
- Canadian Emissions Requirements This Class A digital apparatus meets all requirements of the Canadian Interference-Causing Equipment Regulations. Cet appareil numérique de la classe A respecte toutes les exigences du Règlement sur le matériel brouilleur du Canada.
- VCCI Class A Compliance

この装置は、情報処理装置等電波障害自主規制協議会（VCCI）の基準に基づくクラスA情報技術装置です。この装置を家庭環境で使用すると電波妨害を引き起こすことがあります。この場合には使用者が適切な対策を講ずるよう要求されることがあります。

This is a Class A product based on the standard of the Voluntary Control Council for Interference by Information Technology Equipment (VCCI). If this equipment is used in a domestic environment, radio disturbance may arise. When such trouble occurs, the user may be required to take corrective actions.

---

## EMC DIRECTIVE STATEMENT

- EMC Directive Compliance This equipment was tested and found to conform to the Council Directive 89/336/EEC for electromagnetic compatibility. Conformity with this Directive is based upon compliance with the following harmonized standards:
- |            |   |
|------------|---|
| EN 55022   | Limits and Methods of Measurement of Radio Interference   |
| EN 50082-1 | Electromagnetic Compatibility Generic Immunity Standard:<br>Residential, Commercial, and Light Industry |

**Warning:** This is a Class A product. In a domestic environment, this product may cause radio interference, in which case you may be required to take adequate measures.

---

## LOW VOLTAGE DIRECTIVE STATEMENT

- Low Voltage Directive Compliance This equipment was tested and found to conform to the Council Directive 72/23/EEC for safety of electrical equipment. Conformity with this Directive is based upon compliance with the following harmonized standard:
- |          |  |
|----------|--|
| EN 60950 | Safety of Information Technology Equipment |
|----------|--|

---

## GENERAL APPROVAL STATEMENT FOR UK

- UK General Approval Statement This equipment is manufactured to the international Safety Standard EN60950 and is approved in the UK under the General Approval Number NS/G/12345/J/100003 for indirect connection to the public telecommunication network.

---

## AUSTRALIAN EMC FRAMEWORKS STATEMENT

- Australian EMC Frameworks Compliance This product conforms to the EMC Frameworks and meets the Class A limits of AS3548.

---

**3Com Corporation**  
**5400 Bayfront Plaza**  
**Santa Clara, California**  
**95052-8145**

Copyright © 1999, 3Com Corporation. All rights reserved. No part of this documentation may be reproduced in any form or by any means or used to make any derivative work (such as translation, transformation, or adaptation) without written permission from 3Com Corporation. 3Com Corporation reserves the right to revise this documentation and to make changes in content from time to time without obligation on the part of 3Com Corporation to provide notification of such revision or change.

3Com Corporation provides this documentation without warranty, term, or condition of any kind, either implied or expressed, including, but not limited to, the implied warranties, terms, or conditions of merchantability, satisfactory quality, and fitness for a particular purpose. 3Com may make improvements or changes in the product(s) and/or the program(s) described in this documentation at any time.

3Com registered trademarks are registered in the United States and may or may not be registered in other countries. 3Com, the 3Com logo, and CoreBuilder are registered trademarks of 3Com Corporation.

All other company and product names may be trademarks of the respective companies with which they are associated.