



7600 Fast Ethernet Card

User Guide

<http://www.3com.com/>

Part No. DUA7600-0AAA01
Published November 1997

P
r

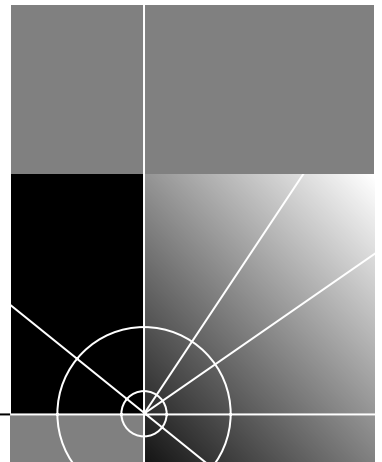

3Com Corporation ■ 5400 Bayfront Plaza ■ Santa Clara, California ■ 95052-8145

© 3Com Corporation, 1996. All rights reserved. No part of this documentation may be reproduced in any form or by any means or used to make any derivative work (such as translation, transformation, or adaptation) without permission from 3Com Corporation.

3Com Corporation reserves the right to revise this documentation and to make changes in content from time to time without obligation on the part of 3Com Corporation to provide notification of such revision or change.

3Com Corporation provides this documentation without warranty of any kind, either implied or expressed, including, but not limited to, the implied warranties of merchantability and fitness for a particular purpose. 3Com may make improvements or changes in the product(s) and/or the program(s) described in this documentation at any time.

UNITED STATES GOVERNMENT LEGENDS:

If you are a United States government agency, then this documentation and the software described herein are provided to you subject to the following restricted rights:

For units of the Department of Defense:

Restricted Rights Legend: Use, duplication or disclosure by the Government is subject to restrictions as set forth in subparagraph (c) (1) (ii) for restricted Rights in Technical Data and Computer Software clause at 48 C.F.R. 52.227-7013. 3Com Corporation, 5400 Bayfront Plaza, Santa Clara, California 95052-8145.

For civilian agencies:

Restricted Rights Legend: Use, reproduction or disclosure is subject to restrictions set forth in subparagraph (a) through (d) of the Commercial Computer Software - Restricted Rights Clause at 48 C.F.R. 52.227-19 and the limitations set forth in 3Com Corporation's standard commercial agreement for the software. Unpublished rights reserved under the copyright laws of the United States.

If there is any software on removable media described in this documentation, it is furnished under a license agreement included with the product as a separate document, in the hard copy documentation, or on the removable media in a directory file named LICENSE.TXT. If you are unable to locate a copy, please contact 3Com and a copy will be provided to you.

Unless otherwise indicated, 3Com registered trademarks are registered in the United States and may or may not be registered in other countries.

3Com, Boundary Routing, CardFacts, LanScanner, LinkBuilder, NETBuilder, NETBuilder II, NetFacts, Parallel Tasking, ViewBuilder, EtherDisk, EtherLink, EtherLink Plus, EtherLink II, TokenLink, TokenLink Plus, and TokenDisk are registered trademarks of 3Com Corporation. 3TECH, CacheCard, FDDLlink, FMS, NetProbe, SmartAgent, Star-Tek, and Transcend are trademarks of 3Com Corporation. 3ComFacts, Ask3Com, and CardBoard are service marks of 3Com Corporation.

CompuServe is a registered trademark of CompuServe, Inc.

Other brand and product names may be registered trademarks or trademarks of their respective holders.

Guide written by Joel Harband. Edited by Patricia Carmel. Technical illustration by Yael Scherzer. Supervised by Marvin Rabinovitch. Production by 3Com.

CONTENTS

ABOUT THIS GUIDE

- Who Should Use This Guide 1
- How to Use This Guide 1
- Conventions 2
 - Informational and Warning Conventions 2
 - Typographical Conventions 2
- Related Manuals 2
 - Documentation Road Map 3

1 OVERVIEW OF THE 7600 CARD

- About the 7600 Card 1-1
 - A Look at the 7600 Card 1-1
 - Port Configurations 1-1
 - Connectors 1-3
 - LEDs 1-3
- 7600 Card Capabilities 1-3
 - 7600 Card Benefits 1-4
 - Ethernet-switching Features 1-4
 - Virtual LANs 1-4
 - Traffic Management 1-5
 - Device Management 1-5
- Typical Applications of the 7600 Card 1-5
 - Fast Ethernet Backbone 1-5
 - Server Farm 1-7

2 INSTALLATION AND POWER-UP

- Safety Precautions 2-1
- Mesures de sécurité 2-2
- Vorsichtsmaßnahmen 2-3
- Installing and Removing the 7600 Card Modules 2-4

Installing the 7600 Card Module	2-4
Removing the 7600 Card Module	2-4
Installing a Fast Ethernet Physical Module	2-5
Connecting to Network Devices	2-5
Connecting to a Local Management Terminal	2-6
7600 Card System States	2-7
System States and LEDs	2-7
Power-Up	2-8
Power-on Self-Test	2-8
Normal operation	2-8
Fast Ethernet Status Indicators	2-8

3 FAST SETUP

Rapid Configuration	3-1
CELLplex 7000 Integrated Fast Setup	3-2
Setup Modes	3-2
Setup Procedure Sections	3-4
Navigation Aids	3-4
Integrated Fast Setup Operation	3-5
Example Dialog	3-6
Multi-context Fast Setup	3-10
Setup Procedure Sections	3-10
Editing Guidelines	3-11
Navigation Aids	3-11
Multi-context Setup Operation	3-12
Sample Screen Dialog	3-12

4 LOCAL MANAGEMENT BASICS

Management Capabilities	4-1
Menu Hierarchy	4-1
Main Menu	4-2
Selecting Menu Options	4-3
Direct Access to Submenus	4-4
Parameter Entry	4-4
Quick Key Functions	4-4
Menu Index	4-6

5 CONFIGURING VIRTUAL LANs

- Display Current Bridge Configuration 5-1
- Attach Fast Ethernet Port to Bridge 5-2
- Attach Internal ATM Port to Bridge 5-3

6 FAST ETHERNET AND BRIDGE MANAGEMENT TASKS

- Fast Ethernet Port Attributes and Statistics 6-2
- Disable a Fast Ethernet Port 6-5
- Display Broadcast Throttling Attributes 6-5
- Update Broadcast Threshold 6-6
- Enable/Disable Broadcast Throttling 6-6
- Update Fast Ethernet Port 6-7
- Bridge Attributes and Statistics 6-8
- Update Bridge-aging-time 6-10
- Bridge-port Attributes and Statistics 6-10
- Display All Entries in Forwarding Database 6-12
- Display Learned Entries in Forwarding Database 6-14
- Display Static Entries in Forwarding Database 6-15
- Enter or Modify a Static Address in FDB 6-19
- Block a Static Address 6-19
- Remove a Static Address from FDB 6-20
- Display STP Enable Status 6-21
- Disable STP on Bridge 6-21
- Display Bridge STP Attributes 6-22
- Update Bridge-wide STP Parameters 6-24
 - Update Bridge-priority 6-24
 - Update Bridge-max-age 6-24
 - Update Bridge-hello-time 6-24
 - Update Bridge-forward-delay 6-25
- Display Bridge-port STP Attributes 6-26
- Disable Bridge-port 6-27
- Update Bridge-port STP parameters 6-27
 - Update Bridge-port-priority 6-27
 - Update Bridge-path-cost 6-28

7 MANAGING ATM RESOURCES

- Display ATM Port Attributes and Statistics 7-2
- Display Bridge ATM address 7-3
- Update Bridge ATM Address 7-4
- Display TM Configuration 7-5
- Enable TM 7-6
- Display TM Clients 7-6
- Add TM Client 7-8
- Remove TM Client 7-8
- Update UNI Version 7-9
- Enable/Disable ATM Port Admin Status 7-9

8 MANAGING LAN EMULATION CLIENTS

- Display LEC Statistics 8-2
- Display Current LEC Configuration 8-4
- Update LECS Address 8-6
- Update ELAN Name 8-6
- Update LES Address 8-7
- Enable LECS Address via ILMI 8-7
- Display LEC Operational Parameters 8-8
- Update LEC Operational Parameters 8-9
 - Control-timeout 8-9
 - VCC-timeout-period 8-10
 - Aging-time 8-10
 - Forward-delay-time 8-11
 - Topology-change-flag 8-11
 - Expected LE_ARP response-time 8-11
 - Flush-timeout 8-12
 - Path-switching-delay 8-12
 - Connection-completion-timer 8-13
- Display LEC Control-frame Statistics 8-14
- Reset LEC Control-frame Statistics 8-17
- Update Unknown Unicast-flood-Mode 8-17

9 SETTING NETWORK PARAMETERS

- Display Current IP Configuration 9-2
- Update IP Address 9-2
- Update Default Gateway 9-3
- Update Subnet Mask 9-4
- Display SNMP Configuration 9-4
- Update NMS IP Address 9-5

10 MANAGING SYSTEM FUNCTIONS

- Display Software Version 10-2
- Display Software Download Status 10-3
- Download Software from Network 10-3
- Erase Software from Flash 10-4
- Download Software from Local 10-4
- Display Hardware Configuration 10-5
- Set System Configuration Mode 10-6
- Set Store-and-Forward Mode 10-7
- Display Timeout Parameters 10-8
- Display Timeout Delays 10-11
- Update Hardware Timeout Delay 10-11
- Update Software Timeout Delay 10-12
- Reset Flash Memory 10-12
- Update Read-access Password 10-13
- Update Write-access Password 10-13
- Update Admin-access Password 10-14
- Enable/Disable Event Messages 10-14
- Reset and Reboot 10-15

11 ETHERNET LANs AND BRIDGES IN THE 7600 CARD

- Overview of Ethernet 11-1
- Fast Ethernet 11-2
 - Capabilities 11-2
 - Cabling 11-4
- Fast Ethernet Ports 11-5
 - Disabling Ports 11-5

Monitoring Ports	11-5
Transparent Bridges	11-6
Store-and-Forward	11-6
Forwarding Database	11-7
Learning Station Addresses	11-7
Static Addresses	11-8
Spanning Tree Protocol	11-8
Re-configuring the Spanning Tree	11-10
Disabling the STP	11-10
Management Bridge Parameters	11-11
Bridged-LAN Environments in the 7600 Card	11-11
Local Bridged-LAN Environment	11-12
Connection to the ATM Network	11-12

12 ATM, LAN EMULATION, AND VIRTUAL LANs

ATM Overview	12-1
ATM Basics	12-2
Cell Switching	12-2
Virtual Channels	12-3
Virtual Channel Connection	12-3
Virtual Path Connection	12-3
Permanent Virtual Channels	12-3
Switched Virtual Channels	12-4
Interim Local Management Interface (ILMI)	12-4
ILMI Management Information Base (MIB)	12-4
ATM Address Registration	12-5
LAN Emulation Overview	12-5
Emulated LAN Components	12-5
LAN Emulation Client	12-6
LAN Emulation Server	12-6
Broadcast and Unknown Server (BUS)	12-6
LAN Emulation Configuration Server (LECS)	12-7
Emulated LAN Connections	12-7
Control VCCs	12-7
LEC Control Frame Statistics Display	12-8
Data VCCs	12-8
LEC Configuration and Status Information	12-9

Bridges in the 7600 Card	12-10
Bridge Forwarding Database	12-12
Address Resolution	12-12
Learning Addresses	12-13
LES Address Registration in the 7600 Card	12-13
Aging in the LE_ARP Cache	12-14
Bridge Frame Forwarding Logic	12-14
Data Transmission over an ELAN	12-15
Unicast Frames	12-15
Unknown Unicast Frames	12-15
Multicast Frames	12-16
Control Information on Data VCs	12-16
LEC Statistics	12-16
LEC Parameters	12-16
Virtual LANs Overview	12-17
Virtual LANs in the 7600 Card	12-18
Connecting Local Segments to a vLAN	12-18
Virtual LANs for three Workgroups	12-21

13 TRAFFIC MANAGEMENT IN THE ATM NETWORK

Overview	13-1
Flow Control Model for ABR	13-2
Traffic Management Concepts	13-3
Explicit Forward Congestion Indication	13-3
Cell Loss Priority	13-3
Implicit Rate Control	13-3
Explicit Rate Control	13-4
Traffic and Congestion Control Functions	13-4
Traffic Rates Shaping in the 7600 Card	13-5
RM Cell Usage	13-5
Flow Rate Adjustment	13-6
Transmission Rate Profiles	13-6
Dual-Rate Mechanism	13-6
Static and Dynamic TM	13-6
TM Remote Client Database	13-6
Traffic Management in the Network	13-7

14 DEVICE MANAGEMENT

- User Interfaces and Protocols 14-1
- In-Band & Out-of-Band Management 14-2
- 7600 Card Management 14-3
 - Local Management (LM) 14-3
 - Simple Network Management Protocol (SNMP) 14-4
 - Virtual Terminal Protocols 14-7

15 SYSTEM MODES, ATTRIBUTES, AND TUNING

- Forwarding Modes 15-1
- Timeout Tuning 15-2
- Console Passwords 15-3

A TECHNICAL SUPPORT

- On-Line Technical Services A-1
 - 3Com Bulletin Board Service A-1
 - Ask3Com on CompuServe A-2
 - 3ComFacts Automated Fax Service A-2
- Telephone Support A-2
 - Support from 3Com A-3
 - Support from Your Network Supplier A-3
 - Returning Products for Repair A-4

B TROUBLESHOOTING

- Solving Common Problems B-1
 - Terminal Does Not Show Anything B-1
 - ACT LED Not Blinking B-1
 - Ethernet Forwarding Failures (Fx port) B-1
- Related Diagnostic Procedures B-2
 - Cleaning Dirty Fiber Optic Cables B-2

C 7600 FAST ETHERNET CARD SPECIFICATIONS

- Physical C-1
- Interfaces C-1
- Fast Ethernet Switching C-1

Environmental	C-2
Indicators	C-2
Management	C-2
Standards Compliance	C-3
Safety	C-3
Electromagnetic Emissions (Agency Certifications)	C-3
Communications Protocols	C-3
Management Protocols	C-3

GLOSSARY

ABOUT THIS GUIDE

The *7600 Fast Ethernet Card User Guide* provides the information required to understand how the 7600 Card works in ATM and Ethernet environments.



If the information in the Release Notes shipped with your product differs from the information in this guide, follow the Release Notes.

Who Should Use This Guide

This guide is intended for the System or Network Administrator responsible for configuring and managing the 7600 Card. It assumes a working knowledge of Local Area Network (LAN) operation and communication protocols.

How to Use This Guide

The following table shows where to find specific information.

If you are looking for information about:	Turn to:
An overview of the 7600 Card key features and technologies.	Chapter 1
Installation and Power-Up of the 7600 Card	Chapter 2
Setting up the 7600 Card	Chapter 3
Local Management Basics	Chapter 4
Configuring Virtual LANs	Chapter 5
Ethernet and Bridge Management Tasks	Chapter 6
Managing ATM Resources	Chapter 7
Managing LAN Emulation Clients	Chapter 8
Setting Network Parameters	Chapter 9
Managing System Functions	Chapter 10
An overview of Ethernet LANs and Bridges	Chapter 11
An overview of ATM, LAN Emulation and Virtual LANs.	Chapter 12
An overview of Traffic Management.	Chapter 13
An overview of Device Management	Chapter 14

If you are looking for information about: (continued)	Turn to:
An overview of system Modes, Attributes and Tuning	Chapter 15
Technical support available for the 7600 Card	Appendix A
Troubleshooting the 7600 Card	Appendix B
Specifications of the 7600 Card	Appendix C



Conventions

Tables 1 and 2 list conventions used throughout this guide.

Informational and Warning Conventions

Table 1 lists informational and warning conventions.

Table 1 Notice Icons

Icon	Type	Description
	Information Note	Information notes call attention to important features or instructions.
	Caution	Cautions alert you to personal safety risk, system damage, or loss of data.
	Warning	Warnings alert you to the risk of severe personal injury.

Typographical Conventions

Table 2 lists the typographical conventions used by this guide.

Table 2 Typographical Conventions

Type	Description
<code>Courier</code>	Used for sample displays to show what appears on your terminal screen.

Related Manuals

Table 3 lists the 7600 Card documentation set and other related manuals.

Table 3 7600 Card Documentation and Related Manuals

Manual Name	3COM Part No.
7600 Fast Ethernet Card User Guide	DUA7600-0AAA01
7600 Fast Ethernet Card System Release Notes	
CELLplex 7000 Operation Guide	DUA3700-0CAA02
CELLplex 7000 Administration Guide	DUA3700-0CAA02
CELLplex 7000 Installation and Setup Guide	DUA3700-0BAA02

Table 3 7600 Card Documentation and Related Manuals (continued)

Manual Name	3COM Part No.
Transcend Enterprise Manager, ATM and VLAN Management	DUA2785-0NAA03

Documentation Road Map

The Documentation Road Map in Table 4 helps you locate specific information in the 7600 Card documentation set.

Table 4 7600 Card Documentation Road Map

If you want to...	Read...
Learn about new features or bug fixes in the 7600 Card software	Release Notes
Learn about changes to the 7600 Card's documentation	Release Notes
Get an overview of the 7600 Card, including system components	User Guide
Learn about various configurations in which you can install your 7600 Card	User Guide
Learn about how you administer and manage the 7600 Card	User Guide
Learn about ATM and how it is implemented in the 7600 module	User Guide
Learn about Ethernet Switching and how it is implemented in the 7600 Card	User Guide
Learn about LAN Emulation and how it is implemented in the 7600 Card	User Guide
Find out what type of configuration tasks you can perform on the 7600 Card	User Guide
Quickly set up your 7600 Card for management access	User Guide
Perform configuration or administration tasks using the Administration Console	User Guide
Get assistance	Technical Support Appendix in any guide

1

OVERVIEW OF THE 7600 CARD

This chapter provides an overview of the 7600 Fast Ethernet Interface Card and its major features and components.

About the 7600 Card

The 7600 Card provides up to 16 Fast Ethernet fiber optic or copper ports and is based on multiple ASIC *ZipChip* technology. Featuring a full or half duplex capability, the 7600 includes fully modular physical interfaces which can be upgraded in the field with a mixture of 100BASE-Fx and Tx ports.

A Look at the 7600 Card

The 7600's front panel includes:

- 16 Fast Ethernet ports
- LED indicators
- Port position indicators

Port Configurations

The 7600 Card provides a base card comprising eight Fast Ethernet 100BASE-Fx (fiber) or 100BASE-Tx (copper) connectors and four optional Fast Ethernet physical modules, which can be installed in configurations of two 100BASE-Fx or 100BASE-Tx ports per module.

Fast Ethernet ports on the base card are numbered 1 to 8, left to right; Fast Ethernet ports on the upper layer physical modules are numbered 9 to 16, left to right. Figure 1-1 shows the front panel of the 7600 Card with the maximum number of Fast Ethernet physical modules installed. Figure 1-2 shows the front panel of the 7600 Card with only the base configuration installed.

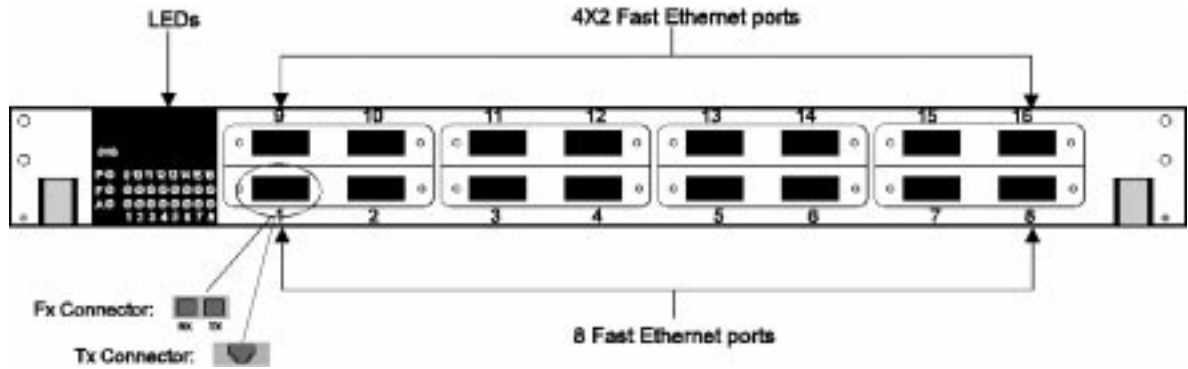

Figure 1-1 Front Panel of the 7600 Card with full configuration

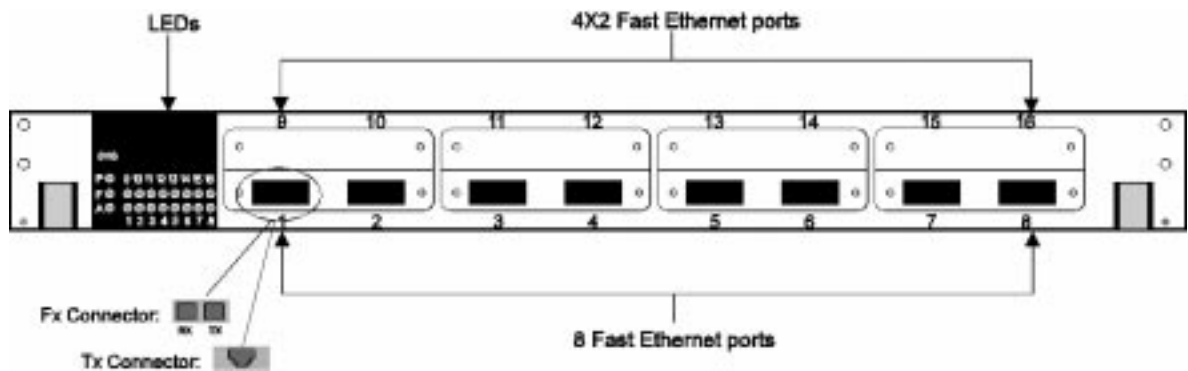

Figure 1-2 Base card with plates covering ports 9-16 (optional modules)

Connectors Fast Ethernet 100BASE-Fx interface connections are made through SC connectors; Fast Ethernet 100BASE-Tx interface connections are made through RJ-45 connectors. These are shown in Figure 1-3 and Figure 1-4 respectively.

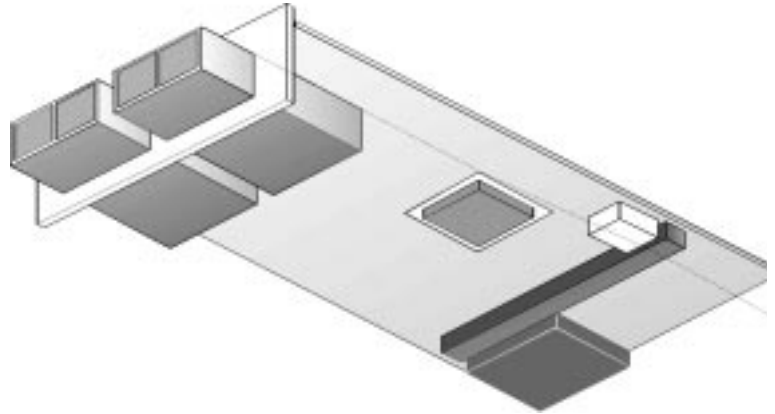

Figure 1-3 Physical module with SC connector for fiber ports

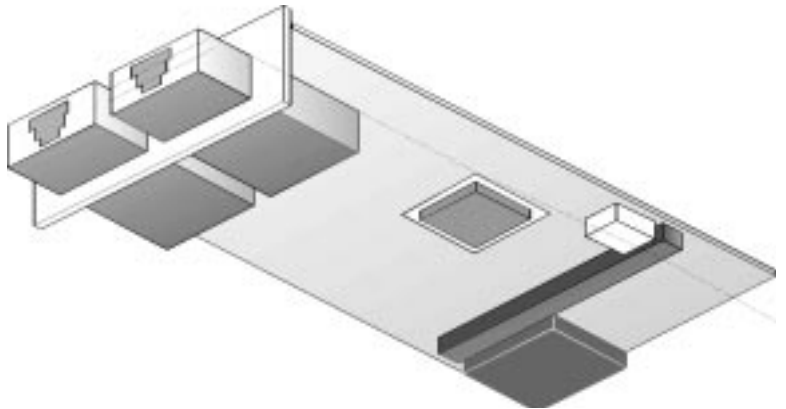

Figure 1-4 Physical module with RJ-45 connector for copper ports

LEDs LEDs at the left side of the front panel indicate the operational status of the 7600 Card and each of the Fast Ethernet ports.

7600 Card Capabilities

The 7600 Card, an integrated 16-port Fast Ethernet card, is part of a series of Ethernet interface cards developed for the CELLplex 7000 ATM

switch and is similar in functionality to the 7200 Ethernet/ATM Interface Card.

7600 Card Benefits

Fast Ethernet switching works with Virtual LANs and management to ensure that information flow does not cross Virtual LAN boundaries. The 7600 Card provides the following benefits:

- Boosts performance for individual workstations where bandwidth demands are high.
- Establishes Virtual LANs across the enterprise.
- Enables Fast Ethernet backbones to downlink from the Super-Stack II Switch 1000 on the desktop to the Fast Ethernet in the basement (see Figure 1-5).
- Relieves traffic bottlenecks for workgroup servers and server farms (see Figure 1-6).

Ethernet-switching Features

The 7600 Card, which implements Fast Ethernet standards 802.3u and Bridging standard 802.1d, includes the following key features:

- Auto-sensing full duplex/half duplex, supported by the TX interface
- Auto-sensing 10/100 Mbps, supported by the TX interface
- Rate-based flow control
- Full rate multicast support
- Address table capacity of up to 32k entries
- Full rate forward/filter
- IEEE 802.1d Spanning Tree Protocol (STP) support
- Virtual LAN support
- LAN Emulation Client (LEC) support
- Local management via the CELLplex 7000's RS-232 port
- Congestion management
- MIBs supported: MIB2, Bridge MIB, AToM MIB, LEC MIB, RMON MIB, Interface Evolution MIB, NCDCHASS MIB (private)

Virtual LANs

Virtual LANs are Ethernet segments grouped together to form a common broadcast domain across the enterprise. Using the 7600 Card, you can establish Virtual LANs using ATM and LAN Emulation. Segments in a

Virtual LAN can incorporate both legacy LANs and ATM devices. Virtual LANs allow the establishment of logical workgroups, independent of physical connections, to achieve more flexible management. Using this feature, you can dynamically set up and manage workgroups composed of members from various departments or business units around the enterprise, regardless of their physical location.

Traffic Management Traffic Management optimizes use of system resources to ensure optimum control of traffic and congestion. The 7600 Card makes use of the ATM Forum Traffic Management standard to expedite traffic to Ethernet workgroup servers and server clusters by providing dynamic traffic rate shaping.

Device Management The 7600 Card can be managed in a number of ways:

- LMA terminal connected by serial line to the local management terminal port on the host CELLplex 7000 switch.
- Telnet over the network via IP connectivity to host CELLplex 7000 switch from a PC or a work station connected in-band.
- *Transcend Enterprise Manager* (or any other SNMP-based network management application) connected over the network to the 7600 Card's IP.

For more information see "Connecting to a Local Management Terminal" on page 2-6 and Chapter 14.

Typical Applications of the 7600 Card

The 7600 Card can be used to advantage in many different locations and configurations. See the following two examples:

Fast Ethernet Backbone

Figure 1-5 shows the 7600 Card used in a Fast Ethernet backbone where the host CELLplex 7000 is located in the data center and each floor is served by a Super-Stack II Switch 1000. The Fast Ethernet downlink from the Switch 1000 units connect to the Fast Ethernet ports of the 7600 Card. Each 7600 Card can handle 16 Switch 1000 units.

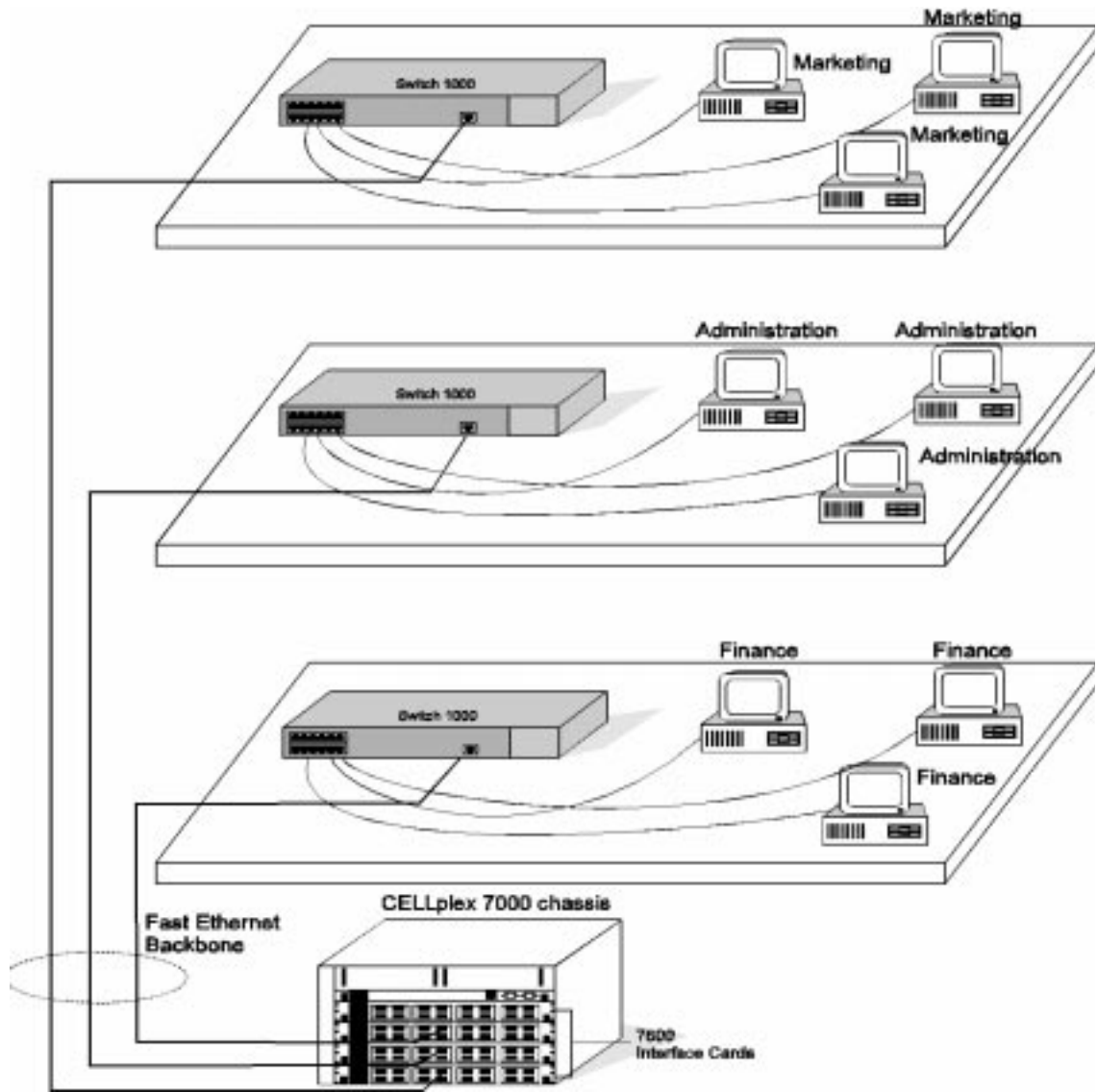

Figure 1-5 Fast Ethernet backbone

Server Farm Figure 1-6 shows the 7600 Card used in a "server farm". Up to 16 servers can be connected through Fast Ethernet links to the 7600 Card. The host CELLplex 7000 is shown connected through ATM links to the Super-Stack II Switch 2700 units located on different floors.

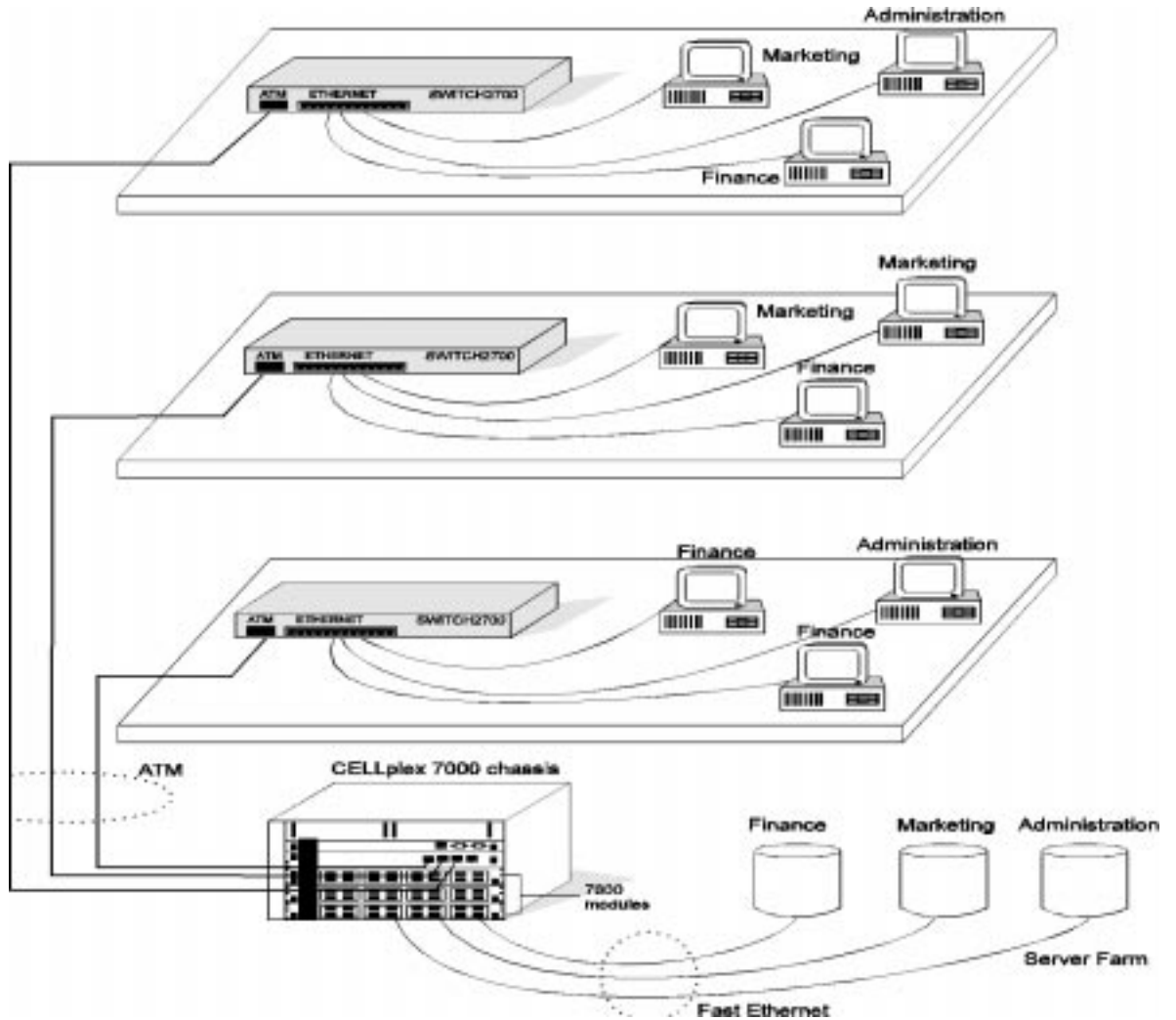

Figure 1-6 Server farm



STARTING UP

Chapter 2 Installation and Power-up

Chapter 3 Fast Setup

2

INSTALLATION AND POWER-UP

This chapter describes the installation of the 7600 Card in a CELLplex 7000 ATM switch, the physical connections to the 7600 Card, and the 7600 Card power-up procedure. It also includes a summary of system states.

The following topics are discussed:

- Safety Precautions
- Installing the 7600 Card
- Installing a Fast Ethernet physical module
- Connecting to network devices
- Connecting to a local management terminal
- 7600 Card System States
- Power-up

Safety Precautions



All servicing should be undertaken ONLY by qualified service personnel.

Read the following safety precautions carefully to reduce the risk of electric shock and fire.

3Com recommends that you use a wrist strap connected to a proper ground when handling replacement parts. This helps prevent the module from being damaged by electrostatic discharge. Additionally, when not in use, the module should be stored in an antistatic bag.

DO NOT insert any metal objects, such as a screwdriver or a ring on a finger, in the open slot when replacing a module while the system is

powered on, This could cause burns or other bodily harm, as well as system damage.

DO NOT operate the unit in a location where the maximum ambient temperature exceeds 40 degrees C.

DO NOT plug in, turn on or attempt to operate an obviously damaged unit.

Ensure that the chassis ventilation openings in the unit are NOT BLOCKED.

Mesures de sécurité



Le service après-vente ne devra être effectué que par un personnel qualifié.

Lire attentivement les mesures de sécurité afin de réduire les risques d'électrocution et d'incendie.»

Lors de la manipulation des pièces de rechange, 3 Com recommande de toujours utiliser une bande attachée au poignet et reliée à la terre. Cela aidera à éviter que la pièce ne soit endommagée par une décharge électrostatique. De plus, lorsqu'il n'est pas utilisé, le module doit être conservé dans un emballage antistatique.

Si le système est alimenté lors de l'installation ou du remplacement d'un module, ne jamais insérer d'objet métallique tel qu'un tourne-vis ou un doigt portant un bijou dans la fente. Cela est susceptible de provoquer brûlures ou autres dommages corporels, et d'endommager le système.

Ne pas faire fonctionner l'unité dans un endroit où la température ambiante maximale dépasse 40 degrés C.

S'assurer que les orifices de la ventilation du châssis de l'unité ne sont pas obstrués.

Ne jamais essayer de brancher, allumer ou faire fonctionner une unité apparemment endommagée.

Vorsichtsmaßnahmen



Jede Wartung sollte NUR von befugtem Wartungspersonal durchgeführt werden.

Lesen Sie die folgenden Vorsichtsmaßnahmen sorgfältig, um das Risiko von Stromschlag oder Brandgefahr zu vermeiden.

Wenn Sie Ersatzteile handhaben, benutzen Sie immer ein Band am Handgelenk, daß gut geerdet ist. Das hilft vermeiden, daß das Ersatzteil durch elektrostatische Entladung beschädigt wird. Darüber hinaus sollte ein Modul, wenn nicht in Gebrauch, in einem antistatischen Beutel aufbewahrt werden.

Steht das System unter Strom, wenn sie ein Modul installieren oder auswechseln, führen Sie keine Metallgegenstände, wie einen Schraubenzieher oder einen Finger mit Schmuck in den offenen Schlitz ein. Das könnte zu Verbrennungen oder anderen Körperschäden führen, sowie auch zu Schäden am System.

Nehmen Sie das Gerät NICHT in Betrieb, falls die Temperatur der Umgebung 40 Grad C übersteigt.

Gehen Sie sicher, daß die Lüftungsöffnungen am Gehäuse NICHT BLOCKIERT sind.

Eine offensichtlich schadhafte Einheit sollte weder angeschlossen, eingeschaltet noch in Betrieb genommen werden.

Installing and Removing the 7600 Card Modules

The following section discusses how to install and remove the 7600 Card and its optional modules.

Installing the 7600 Card Module

To install the 7600 Card module into the CELLplex 7000 chassis, perform the following steps:

- 1 Pull the ejector tabs on each side of the front panel to their outermost position and orient the 7600 Card in front of the selected slot of the CELLplex 7000.
- 2 Place the module between the runners of the selected slot and slide it into the CELLplex 7000 chassis until it reaches the backplane and can go no further.



While sliding the 7600 Card into chassis, make sure that the loose hex spacers on the card do not interfere with inserting the module.

- 3 Make sure the ejector tabs are still in their outermost position and give the module a firm push to ensure that the card has fit snugly into the connectors on the backplane.
- 4 Push the ejector tabs to their innermost position to lock the module in place.



You may have to apply pressure on the tabs in order to ensure that the board is firmly in place in the connectors in the backplane. An audible click indicates that the connectors have engaged.

- 5 Pull the ejector tabs to the middle position.
- 6 Tighten the module's securing screws on the front panel.

Removing the 7600 Card Module

To remove the 7600 Card from the CELLplex 7000 chassis perform the following steps:

- 1 Release the screws on the front panel.
- 2 Pull the ejector tabs to their outermost position and carefully slide the module out.



The 7600 Card module can be inserted into or removed from the chassis of the CELLplex 7000 ATM switch while the switch is powered up (i.e., hot-swapped).

Installing a Fast Ethernet Physical Module

You can install up to four, 2-port Fast Ethernet physical modules on to the 7600 Card. Each module can be configured for either 100BASE-Fx or 100BASE-Tx connections.

The 7600 Card is supplied with 12 male/female spacers with which to attach the physical modules.

To install a physical module on to the 7600 Card module, perform the following steps:

- 1 Remove the 7600 Card module from the CELLplex 7000 chassis if it is already installed.
- 2 Remove the plate covering the cutout for the connector from the front panel.
- 3 Hold the physical module at an angle behind the front panel so the connectors on the physical module are aligned with the unoccupied cutout on the front panel, and insert the connector into the cutout. (See 1 in Figure 2-1).

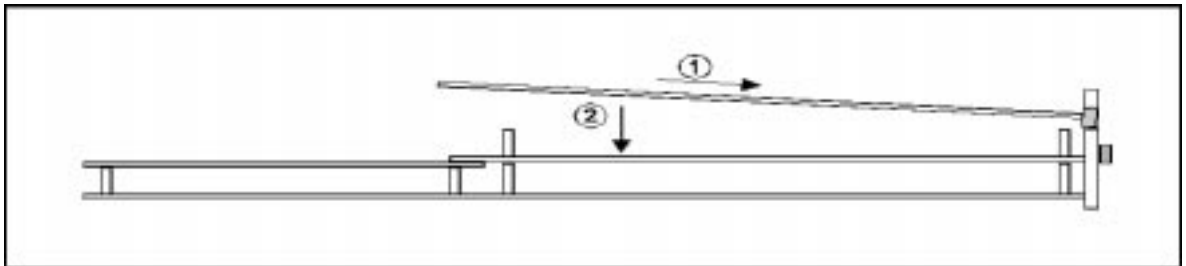

Figure 2-1 Installing a Fast Ethernet physical module

- 4 Lower the card on to the spacers located on the 7600 Card, making sure that the screws on the physical module fit into the spacers. (See 2 in Figure 2-1).
- 5 Tighten the screws to fix the module in place.

Connecting to Network Devices

Fast Ethernet TX ports (RJ-45) use CAT-5 STP (shielded twisted pair); Fast Ethernet FX ports (SC connectors) use multi-mode, fiber cable. The connectors TP or TX are configured as MDIX, suitable for direct connection to a workstation or other DTE, using a normal, straight-through twisted-pair cable. To connect a 7600 Card to another 10/100BASE-T switch, you can use either a crossover cable or, if

applicable, set the port on the connected device to MDI and use a straight-through cable.

Connecting to a Local Management Terminal

The following section describes the physical connection of the 7600 Card to a local terminal via the CELLplex 7000 switch.

All interface cards in the CELLplex 7000 can be managed via the serial port, using an RS-232 connection through a female 9-pin D-type connector.

During installation, use a shielded cable for the management connector.

The CELLplex 7000 switch module's serial port is set to function with the connected equipment according to the following values:

Table 2-1 Serial Port Settings

Serial Port Setting	Value
Baud Rate	19200
Character Size	8 Bit
Stop Bit	1
Parity	No Parity
Flow Control	Xon/Xoff

7600 Card System States

This section describes the different system states of the 7600 Card and how they are indicated on the LED display.

System States and LEDs

The following Table 2-2 lists the system states of the 7600 Card module in the first column. The state in which the 7600 Card is currently operating is displayed by the system status LEDs. Referring to Figure 2-2, these are the three LEDs: P(ower), F(ail), and A(ctive) under the label "SYS" on the left side of the LED panel. Table 2-2 shows the correlation between the current system state and SYS LEDs.

Table 2-2 7600 Card System States

System State	SYS LED		
	Power (green)	Fail (red)	Active (orange)
Power-up	On	Random	Random
Normal operation	On	Off	Flashing
Hardware fault	On	On	Off
Software fault	On	Off	Not flashing
No power to unit	Off	Off	Off

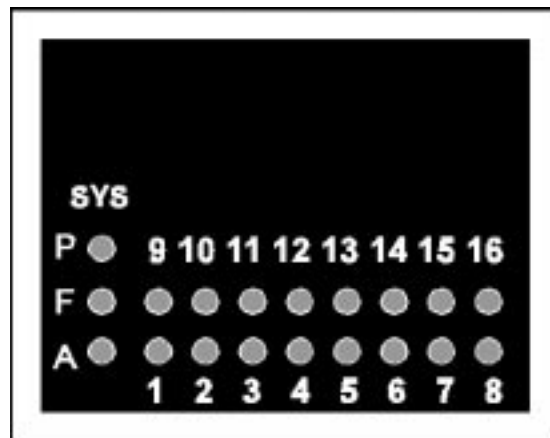

Figure 2-2 7600 Card LEDs

Table 2-3 also provides information about the system states but is organized by system status LED. The meaning of each SYS LED mode is described.

Table 2-3 System Status LEDs

SYS LED	Mode	Meaning and User Action
Power (green)	On	Unit is functioning properly.
	Off	If the unit is not functioning, contact your supplier.
Fail (red)	On	A hardware fault in the unit has been detected. If possible, extract the 7600 Card from the chassis and plug it back in. If this fails to rectify the problem, contact your supplier.
	Off	No hardware fault detected.
Active (orange)	Flashing	Normal operation.
	Steady	A software problem has been detected. If possible, extract the 7600 Card from the chassis and plug it back in. If this fails to rectify the problem, contact your supplier.

Power-Up

When the 7600 Card is powered-up, it automatically begins the power-up phase and initiates the Power-On Self-Test.

Power-on Self-Test

The 7600 Card's automatic Power-On Self-Test verifies that every component in the system is fully functional.

While the Power-On Self-Test is in progress, the Power LED is green. When the Power-On Self-Test is completed, the Power LED maintains a steady green and the Active orange LED flashes to indicate that the unit is functioning. If the unit is not functioning, the light goes off; in such a case, contact your supplier.

The Power-On Self-Test should take a maximum of sixty seconds.

Normal operation

After completion of the Power-on Test, the 7600 begins normal operation automatically. The LEDs continue to display the system status of the 7600 Card module as well as the individual data connections of each Fast Ethernet LED display.

Fast Ethernet Status Indicators

Referring to Figure 2-2, each of the 16 multi-color LEDs corresponds to the 16 Fast Ethernet ports in each connector on the front panel, according to the same geometrical configuration. Each multi-color LED can appear in one of three states: green, orange or off.

The purpose of the Fast Ethernet LEDs is to display the connection status and traffic status on the corresponding Fast Ethernet port. These are displayed according to the following table:

Table 2-4 Fast Ethernet Port LEDs

LED (Color)	Meaning
Link status (Green)	The port is connected.
Packet status (*Orange)	There is active traffic on the port.
Link and Packet (Green and Orange)	The port is connected and traffic is flowing into the port.
Off	The port is not connected.

* The orange light intensity indicates the traffic percentage

3

FAST SETUP

This chapter describes two methods of configuring the 7600 Card which allow it to function in the network almost immediately.

The following methods are discussed:

- Integrated Fast Setup of the host CELLplex 7000
- Multi-context Fast Setup of the 7600 Card

Rapid Configuration

After the 7600 Card has been physically connected to your site network devices and power has been applied, you must make the logical connections that enable the 7600 Card and its attached devices to function as a networked whole.

There are two ways to perform a “Fast Setup” that will enable the 7600 Card to begin functioning almost immediately:

- Performing the Integrated Fast Setup procedure of the host CELLplex 7000, which configures all its interface cards in one session.
- Accessing the 7600 Card separately and performing its Multi-context Fast Setup procedure.



The Integrated Fast Setup is recommended for most users.

CELLplex 7000 Integrated Fast Setup

The CELLplex 7000 Switch local management software features an Integrated Fast Setup procedure which configures both the Switch and all Interface Cards installed in it in one continuous dialog.

Box-oriented setup

The Integrated Fast Setup procedure is based on a concept in which the CELLplex 7000 Switch together with its installed interface cards is viewed as an integrated unit or *box*. The advantage of this point of view is its simplicity: it is not necessary to remember into which slot each Interface Card is installed or even which type of Interface Card is installed. Rather, attention is focussed on configuring the ports of the box. The procedure automatically determines the ports that are available in the box and presents them by type (Ethernet, Fast Ethernet, ATM) for configuration. The port location is displayed by the notation <slot.port>. For example <3.1> refers to slot #3, port #1.

Box-wide VLANs

With the Integrated Fast Setup, Virtual LANs (VLANs) are created box-wide. Each VLAN is defined for both the Switch and all the Interface Cards installed in the box. There is only one admin VLAN for the box.

VLANs are set up in two stages. First, in the LE Client section, a number of *potential* VLANs are created according to the requirement of the network. Next, in the Virtual Network Configuration section, the potential VLANs become actual VLANs by having ports assigned to them.

Setup Modes

The Integrated Fast Setup provides two setup modes: the "Full" setup mode and the "Switch" setup mode.

Full Setup Mode

The Full setup mode configures both the CELLplex 7000 Switch and the installed Interface Cards. It sets the required parameter values in all the installed Interface Cards and is the preferred setup mode for most users. In order to facilitate a more efficient procedure, the Full setup mode presents only the most critical parameters; default values are assumed for the remaining parameters.

Only those systems that require specific parameter settings in one or more of the installed Interface Cards will need to use the Switch setup mode as described in the next section.

Switch Setup Mode

The Switch setup mode focusses only on the CELLplex 7000 Switch and its ATM ports without altering Interface Card configuration. The Switch setup mode is provided to allow you to retain special settings in the Interface Cards.

Setup Mode Selection

If any of the settings in the following list are present in any Interface Card, the operator is prompted to choose between the Switch and Full setup modes:

- A Subnet Mask, Default Gateway or NMS Address different from that of the CELLplex 7000 Switch
- A vLAN whose ATM connection is set to "No"
- The name of the ELAN that the default admin port (Port #1 in each slot) is attached to differs from the name "admin"

If Full setup is selected, the parameters in the Interface Cards revert to their default values.

If none of these situations are detected the Full setup mode is executed automatically.

Setting Special Parameters

In case one or more individual Interface Cards requires one of the special situations referred to in the previous section or needs to remain unaltered, you will need to do one of the following:

- Use the Switch setup mode of the Integrated Fast Setup to set up the CELLplex 7000 Switch only and then use the Multi-context Fast Setup of each installed Interface Card separately (see "Multi-context Fast Setup" on page 3-10).
- Use the Full setup mode of the Integrated Fast Setup to configure the CELLplex 7000 Switch and all installed Interface Cards and then use the Multi-context Fast Setup for the particular Interface Card in order to restore its special parameter values.

Setup Procedure Sections

The Integrated Fast Setup consists of the following steps or sections:

Table 3-1 Integrated Fast Setup Procedure Sections

Setup Section	Description
Network Prefix	See CELLplex 7000 Manual.
LE Parameters	See CELLplex 7000 Manual.
LECS Address	See CELLplex 7000 Manual.
UNI/NNI parameters	See CELLplex 7000 Manual.
LE Client Configuration	Potential vLANs are defined by assigning names to ELANs. Exit this section by pressing Enter only.
Virtual Network Configuration	Box ports are assigned to potential vLANs.
Admin VN Management Configuration	Sets up admin vLAN in all modules including setting IP address. See CELLplex 7000 Manual.
Confirmation	Setup is confirmed by operator.

Navigation Aids

The following short-cut characters are provided to move between sections of the setup procedure:

Table 3-2 Setup Procedure Navigation Aids

Type:	To perform:
<	Jump to previous section.
>	Jump to next section.
>S	Jump to section according to double underlined ID letter in section title.
\	Jump to beginning of setup.
\$	Jump to end of setup.
}G	Jump to slot #G (in VN Configuration section).
+I	Jump to port #I (in VN Configuration section).
*	Update and duplicate to all slot items (in VN Configuration section).
**	Update and duplicate to all section items (in VN Configuration section).

Integrated Fast Setup Operation The Integrated Fast Setup is initiated from the LMA Main Menu of the CELLplex 7000. The CELLplex Main Menu appears as follows:

```

CP7000 switch module - Main Menu:
  (1) SYS: Platform config ->
  (2) LEM: Lan Emulation ->
  (3) CON: Connections ->
  (4) STS: Statistics ->
  (5) DIA: Testing & Diagnostics ->
  (6) FTR: ATM features
  (7) LOG: Logout
  (8) VER: Version
  (9) FST: Fast Setup
(10) DBG: Debug ->
[ '\ ' -Main,      '- ' -Back in menus]
[ '=0'-To switch, '=n'-To i/f card n (1-4)]

```

Select the menu item: (9) FST: Fast Setup



Note that the Integrated Fast Setup "Full" setup mode may override any specific configurations that have previously been carried out in any of the installed Interface Cards. The following warning message is displayed when this is about to occur:

```

***Note: Full fast setup, special module configuration will
be overridden.

```

Example Dialog The following dialog appears on the screen:

```

Now reading the modules configuration, please wait ...

Special module configuration will be overridden by fast setup.
continue full fast setup or only switch fast setup (S<witch>, F<ull>): F

***Note: Full fast setup, special module configuration will be overridden.

Fast Setup Utility
=====

The flash configuration will be displayed below;
Update if needed, and then hit Enter.

To move between sections, enter the following characters at end of line:
< > - Back and forth in sections      >S - Jump to section ID S
\   - Back to beginning of setup      $   - To end of setup

Only in Virtual Network Configuration section (group=slot; item=port):
}G - Jump to group #G                  +I - Jump to item #I
*   - Update all group items           ** - Update all section items

```

Network Prefix Section

```

Network Prefix
=====

*** Note: Recommended Network Prefix ->
                47.00.00.00.00.00.3c.00.00.a*
Network Prefix(In HEX): 47.00.00.00.00.00.3c.00.00.a*

```

LE Parameters Section

```
LE parameters
=-----
Resident LECS state (1-Enable, 0-Disable): 0
LES state (1-Enable, 0-Disable): 0
```

LECS Address Section

```
LECS Address
--=-----
Active LECS addr - net prefix: 47.00.00.00.00.00.3c.00.00.a*
Active LECS addr - user part: 00.a0.3e.00.00.01.00
```

UNI/NNI Parameters Section

```
UNI/NNI parameters
=-----
NNI max hops (0 - 120): 7
NNI type of port <3.1> (U<NI>, N<NI>, G<ateway>): U
NNI type of port <3.2> (U<NI>, N<NI>, G<ateway>): U
NNI type of port <3.3> (U<NI>, N<NI>, G<ateway>): U
NNI type of port <3.4> (U<NI>, N<NI>, G<ateway>): U
NNI type of port <4.1> (U<NI>, N<NI>, G<ateway>): U
NNI type of port <4.2> (U<NI>, N<NI>, G<ateway>): U
NNI type of port <4.3> (U<NI>, N<NI>, G<ateway>): U
NNI type of port <4.4> (U<NI>, N<NI>, G<ateway>): U
NNI type of port <5.1> (U<NI>, N<NI>, G<ateway>): U
NNI type of port <5.2> (U<NI>, N<NI>, G<ateway>): U
NNI type of port <5.3> (U<NI>, N<NI>, G<ateway>): U
NNI type of port <5.4> (U<NI>, N<NI>, G<ateway>): U
NNI type of port <6.1> (U<NI>, N<NI>, G<ateway>): U
NNI type of port <6.2> (U<NI>, N<NI>, G<ateway>): U
NNI type of port <6.3> (U<NI>, N<NI>, G<ateway>): U
NNI type of port <6.4> (U<NI>, N<NI>, G<ateway>): U
```

LE Client Configuration Section

```

LE Client Configuration
-----
*** Hit Enter after VN #7 for end of potential ELAN names list.

VN #1 ELAN Name: admin    < Admin VN >
VN #2 ELAN Name: finance
VN #3 ELAN Name: engineering
VN #4 ELAN Name: engineering2
VN #5 ELAN Name: marketing
VN #6 ELAN Name: sales
VN #7 ELAN Name: office
VN #8 ELAN Name: foreign
VN #9 ELAN Name: reserve
VN #10 ELAN Name: marketing
*** VN #5 already has this ELAN name.

VN #10 ELAN Name: secret
VN #11 ELAN Name:

```

Virtual Network Configuration Section

```

Virtual Network Configuration
-----
Fast Ethernet <3.1> belongs to VN # (1-6): 1 < Admin VN >
Fast Ethernet <3.2> belongs to VN # (1-6): 2
Fast Ethernet <3.3> belongs to VN # (1-6): 2
Fast Ethernet <3.4> belongs to VN # (1-6): 3
Fast Ethernet <3.5> belongs to VN # (1-6): 3
Fast Ethernet <3.6> belongs to VN # (1-6): 4
Fast Ethernet <3.7> belongs to VN # (1-6): 4
Fast Ethernet <3.8> belongs to VN # (1-6): 5
Fast Ethernet <3.9> belongs to VN # (1-6): 5
Fast Ethernet <3.10> belongs to VN # (1-6): 5
Fast Ethernet <3.11> belongs to VN # (1-6): 6
Fast Ethernet <3.12> belongs to VN # (1-6): 6
Fast Ethernet <3.13> belongs to VN # (1-6): 6
Fast Ethernet <3.14> belongs to VN # (1-6): 6
Fast Ethernet <3.15> belongs to VN # (1-6): 6
Fast Ethernet <3.16> belongs to VN # (1-6): 6
*** Note: no ports assigned to VN #6 - ELAN : sales

```

Admin VN Management Configuration Section

```
Admin VN Management Configuration
-----
```

```
Switch IP address: 100.0.0.1
Slot #3 IP address: 100.0.0.100
NMS address: 255.255.255.0
Default Gateway: 255.255.255.255
Subnet Mask: 255.255.255.0
```

Confirmation Dialog Section

```
Accept Changes
-----
```

```
*** Note: Change of some parameters will take affect now!!
```

```
Save changes (Y/N)? Y
Are you sure (Y/N)? y
Saving NMS parameters...
Saving LE parameters...
Saving Network Prefix...
Saving resident LECS Address...
Saving active LECS Address...
Saving NNI parameters...
The switch new configuration has been saved.
```

```
Now applying the module in slot #4 ...
```

```
Due to new VN configuration, some saved static
entries in slot #4 have been invalidated.
```

```
The new VN configuration in slot #4 has been applied and saved.
```

```
Now applying the module in slot #5 ...
```

```
Due to new VN configuration, some saved static
entries in slot #5 have been invalidated.
```

```
The new VN configuration in slot #5 has been applied and saved.
```

```
All the modules new configuration has been applied.
```

Multi-context Fast Setup

This section describes how to perform the card-specific Multi-context Fast Setup to perform a rapid configuration of the 7600 Card.

Port Context

For the purpose of management, the 16 Fast Ethernet ports of the 7600 Card are divided into four *contexts*. These are displayed in the following table:

Table 3-3 Port Context

Context t	#0	Context t	#1	Context t	#2	Context t	#3
9	10	11	12	13	14	15	16
1	2	3	4	5	6	7	8

The management menus and commands focus on one context at a time. Each menu displays the currently active context. To work with a certain port, first use the table to ascertain to which context the port belongs. For example, ports 1, 2, 9, 10 belong to Context #1. Then change to that context by entering ".n" where n is the context number. From that point on, the menus related to the ports in that context are displayed.

The Multi-context Fast Setup procedure described in the next section runs through all contexts automatically so that you can set up all the ports in the device in one continuous dialog.

Setup Procedure Sections

The following describes the main steps of the Multi-context Fast Setup:

- Virtual Network Configuration. Each Fast Ethernet port is assigned to a logical bridge. Initially, all ports default to the "admin" vLAN. Bridge 0 is the default bridge to which port 1 is always initially assigned for ease of management setup.
- Emulated LAN (ELAN) Configuration. The ELAN name and LES address can be assigned for each logical bridge specified in the virtual network configuration with an ATM connection. This information is necessary for communication within virtual networks. All logical bridges assigned to the same LES address or ELAN name, are defined as being in the same ELAN.
- Management Configuration. The IP address and Network Management Station (NMS) address, with their default gateways and

subnet masks, can be assigned to each logical bridge defined in the Virtual Network Configuration.

- System Mode Configuration. The 7600 Card can be configured to operate in one mode: LAN Emulation (LE).

Editing Guidelines

The following are the editing rules for Fast Setup values:

- The current value of each parameter is displayed as though it has already been typed and may be either altered and entered or immediately entered as is.
- The parameters may be edited as detailed in Chapter 4.

Navigation Aids

The following short-cut characters are provided to move between sections of the setup procedure:

Table 3-4 Setup Procedure Navigation Aids

Type:	To go to:
<	Previous section
>	Next section
+	Next parameter
-	Last parameter
\$	'Accept Changes' section (if no changes have been made, you quit Fast Setup and return to the Main Menu)
\	Beginning of setup

**Multi-context Setup
Operation**

From the CELLplex 7000 Main Menu enter = <slot #> where <slot #> is the number of the slot in which the 7600 Card is installed. The 7600 Card admin Main Menu appears as in the following example:

```
Context #0 - main menu:
=====
[1] system - Administer System level functions ->
[2] ethernet - Administer Ethernet ports ->
[3] bridge - Administer Bridging ->
[4] atm - Administer ATM resources ->
[5] le - Administer LAN Emulation Clients ->
[6] vns - Administer Virtual Networks configuration ->
[7] management - Administer IP and SNMP ->
[8] quit - Logout of the administration console
[9] fast - Fast Setup
```

To perform the Multi-context Fast Setup use menu item [9]fast from the main menu.

Sample Screen Dialog

The Multi-context Fast Setup appears as follows:

```
Multi-context Fast Setup Utility
=====

Answer Y(es) or N(o), and then hit Enter.

To move between question, enter the following characters at end of line:
< > - Back and forth in sections \ - Back to beginning of setup
$ - To end of setup

Do you want to enter Fast Setup for context #0 (Y/N)?Y
```

Virtual Network Configuration Section

```

Virtual Network Configuration
-----
Fast Ethernet port #1 belongs to Bridge No.(0-3): 0 <Admin VN>
Fast Ethernet port #2 belongs to Bridge No.(0-3): 0
Fast Ethernet port #3 belongs to Bridge No.(0-3): 1
.
.
.
#4
Bridge #0 ATM connection (Y/N)? Y <Admin VN>
Bridge #1 ATM connection (Y/N)? Y

```

ELAN Configuration Section

```

Emulated LAN (ELAN) Configuration
-----
Enable get LECS address via ILMI (Y/N)?
Bridge #0 ELAN name: elan156_0
Bridge #0 LES: 11.22.33.44.55.66.77.88.99.0.aa.bb.cc.dd.ee.ff.11.22.33.44

```

Management Configuration Section

```

Management Configuration
-----
Bridge #0 IP Addr: 140.204.140.177
Bridge #0 Default Gateway: 140.204.140.99
Bridge #0 Subnet Mask: 255.255.0.0
Bridge #0 NMS Addr: 140.204.140.165
Bridge #1 IP Addr: 140.204.140.178
Bridge #1 Default Gateway: 140.204.140.99
Bridge #1 Subnet Mask: 255.255.0.0
Bridge #1 NMS Addr: 140.204.140.166

```

System Mode Configuration Section

```
System Mode Configuration
```

```
-----
```

```
Enter system mode (L<E>): L
```

The new configuration is displayed for this context.

Confirmation Dialog Section

```
Accept Changes (if changes have been made)
```

```
-----
```

```
Save changes (Y/N)? Y
```

```
This will apply the changes and reset the affected bridges only! Are you sure  
(Y/N)?
```

At this point you are asked if you want to enter Fast Setup for contexts 1, 2, and 3.

II

7600 CARD MANAGEMENT TASKS

- Chapter 4 Local Management Basics
- Chapter 5 Configuring Virtual LANs
- Chapter 6 Fast Ethernet and Bridge Management Tasks
- Chapter 7 Managing ATM Resources
- Chapter 8 Managing LAN Emulation Clients
- Chapter 9 Setting Network Parameters
- Chapter 10 Managing System Functions

4

LOCAL MANAGEMENT BASICS

This chapter describes the use of the 7600 Fast Ethernet Interface Card Administration Console, its Main menu display and its controls. A Menu Index is also included which provides a reference to the command description for each menu command.

Management Capabilities

The administration console configures your 7600 Card. It also provides some network management capabilities. To augment network management, you can use an external application, such as 3Com's Transcend™ Enterprise Manager ATMvLAN Manager.

Administration Console functions include:

- System functions administration
- Ethernet ports administration
- Basic bridge and port features administration
- ATM resources configuration
- LAN Emulation Clients administration
- Virtual Networks management
- IP address configuration for system access by Telnet, SNMP, or FTP

Menu Hierarchy

The management commands are organized in a hierarchical menu system. At first, the Main menu is displayed showing the main topics for management such as "system", "ethernet" and "bridge". Under each main topic is a submenu which shows more specific command topics. These submenus may themselves have submenus and so on until the actual management commands are displayed. The menu structure appears in Figure 4-1 below.

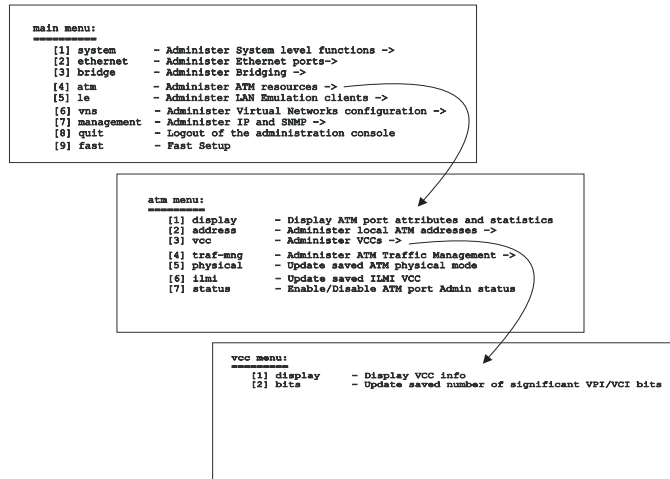

Figure 4-1 Hierarchic menu structure

Main Menu The Main menu is accessed from the CELLplex 7000 Main menu by typing = <slot #> where “<slot #>” is the number of the slot in which the 7600 Card is installed. Figure 4-2 shows the Main menu.

```

7600 Card in slot # 2 Context #0 - main menu:
=====
[1] system - Administer System level functions ->
[2] ethernet - Administer Ethernet ports ->
[3] bridge - Administer Bridging ->
[4] atm - Administer ATM resources ->
[5] le - Administer LAN Emulation Clients ->
[6] vns - Administer Virtual Networks configuration ->
[7] management - Administer IP and SNMP ->
[8] quit - Logout of the administration console
[9] fast - Fast Setup
    
```

Figure 4-2 Main menu

The arrow symbol (->) indicates that the menu option branches off into one or more submenus.

Port Context

For the purpose of management, the 16 Fast Ethernet ports of the 7600 Card are divided into four *contexts* as follows:

Table 4-1 Port Context

Context t	#0	Context t	#1	Context t	#2	Context t	#3
9	10	11	12	13	14	15	16
1	2	3	4	5	6	7	8

The management menus and commands focus on one context at a time. Each menu has the currently active context displayed above it. To work with a certain port, use the above table to ascertain which context it is in. For example, ports 1, 2, 9, 10 belong to context #1. Then change to context n, by entering ".n" at the command prompt as discussed below. From then on, the menus related to the ports in that context will be displayed.

Selecting Menu Options

The angle bracket symbol (>) is displayed below each menu and prompts the keyboard entry of a menu option. A menu option can be entered either by option number or option name. Only the first unique character(s) of the menu option name needs to be entered.

For menu options below the Main menu, the menu option label precedes the angle bracket prompt. Successive submenu prompts define the hierarchical path from the most recently invoked (and most deeply embedded) submenu to the original (root) Main menu option. When there are no more submenus to call up, the last submenu option entered produces a double angle bracket prompt (>>). This prompt indicates that menu option parameters must now be entered.

Example

Thus, for example, entering 3 after the Main menu prompt produces the `bridge` submenu, with its various options, and a command line following the prompt:

```
(3)bridge>
```

Keying in this submenu's 4 option gives you the prompt:

```
(3)bridge\4)stp>
```

Entry of the stp submenu's 3 option produces the prompt:

```
(3)bridge\4)stp\3)port>.
```

Finally, entering 1 finalizes the prompt as:

```
(3)bridge\4)stp\3)port\1)display>>
```

Direct Access to Submenus

To select an embedded sub-menu or settings-option several levels deep in your current menu without having to step down through the sub-menus, type all the intervening menu numbers or initial characters with blanks in between. For example, if you wish to display the complete FDB table, type **b f d** from the Main menu. This is a shortcut to selecting **b** (bridge) on the Main menu, **f** (fdb) on the Bridging menu, and **d** (display) on the Forwarding Database menu. The number sequence for this example would be **3 3 1**. In Part II, each command description includes the menu sequence required to perform the command directly.

Should you enter an illegal character or string (such as an out-of-range parameter), the display will respond with an error message indicated by a three-asterisk (***) prefix.

Parameter Entry

When prompted for parameters, you can enter them all on the same command line with blanks in between or you can enter some or all of them on separate command lines. You are repeatedly prompted for the remaining parameter as follows:

```
Enter parameter(s): 'Bridge No. ' 'Bridge Priority'
```

All or some of the parameters may also be entered in the same command line immediately following the selected menu option or sequence of menu options. In some instances separate prompts call for additional parameters which must be entered in their individual prompt line.

Once all the parameters at the lowest submenu level have been entered, the option is activated and the output is displayed.

Quick Key Functions

The following quick key functions are available when working with the management menus. Table 4-2 covers navigating functions in the menu system; Table 4-3 covers aids for editing parameters.

Table 4-2 Menu Navigation Functions

Type:	To go to:
\	Main menu from any point.
-	Previous menu.
Left/Right Arrows	Back and forth within the command line.
Home	Beginning of the command line.
End	End of the command line.
.n	Context n (0-3)
=n	Another module n=0: Switch module n=1-4: Interface Card module 1-4

Table 4-3 Editing Aids

Type:	To perform:
<	Clear the value of the parameter last entered.
>	Clear the values of all the parameters in the list just entered.
Up arrow	Retrieve a previous command.
Down arrow	Get the next command.
Backspace	Delete the character preceding the insertion point
Del	Delete the character following the insertion point.
Ins	Toggle between Insert and Overwrite modes.
5	Clear the command line.
\$	Escape from prompt

Menu Index

The following index shows where to find the description of each menu action in the following chapters. The index has the same structure as the menu hierarchy.

System Management Menu

- [1] system
 - [1] display..... 10--2
 - [2] status..... 10--3
 - [3] update..... 10-3
 - [5] mode..... 10-6
 - [6] s&f..... 10-7
 - [7] tuning..... 10-7
 - [8] timeout
 - [1] info..... 10-8
 - [2] display..... 10-11
 - [3] hardware..... 10-11
 - [4] software..... 10-12
 - [5] flash..... 10-12
 - [6] password
 - [1] read..... 10-13
 - [2] write..... 10-13
 - [3] admin..... 10-14
 - [7] event..... 10-14
 - [8] reset..... 10-15
 - [9] load
 - [1] display..... 10-3
 - [2] tftp..... 10-3
 - [3] local..... 10-4

Ethernet Menu

- [2] ethernet
 - [1] display..... 6-2
 - [2] status..... 6-5
 - [3] bcast
 - [1] display..... 6-5
 - [2] update..... 6-6

.....[3] state	6-6
.....[4] update.....	6-7

Bridge Menu

[3] bridge	
.....[1] display.....	6-8
.....[2] port.....	6-10
.....[3] fdb	
.....[1] display.....	6-12
.....[2] learned.....	6-14
.....[3] static.....	6-15
.....[4] allow.....	6-19
.....[5] block.....	6-19
.....[6] remove.....	6-20
.....[4] stp	
.....[1] display.....	6-21
.....[2] bridge	
.....[1] display.....	6-21
.....[2] priority.....	6-24
.....[3] max-age.....	6-24
.....[4] hello.....	6-24
.....[5] forward.....	6-25
.....[3] port	
.....[1] display.....	6-26
.....[2] priority.....	6-27
.....[3] cost.....	6-28
.....[4] status.....	6-27
.....[4] status.....	6-21
.....[5] aging.....	6-10

ATM Menu

[4] atm	
.....[1] display.....	7-2
.....[2] address	
.....[1] display.....	7-3
.....[4] change.....	7-4

- [3] vcc
- [4] tm
- [1] display..... 7-5
- [2] enable 7-6
- [3] client
- [1] display..... 7-6
- [2] add 7-8
- [3] remove 7-8
- [6] uni 7-9
- [8] status 7-9

LAN Emulation Menu

- [5] le
- [1] display..... 8-2
- [2] config
- [1] display..... 8-4
- [4] cs-addr..... 8-6
- [5] elan-name 8-6
- [6] les-addr 8-7
- [7] mode-lecs..... 8-7
- [3] operational
- [1] display..... 8-8
- [2] control..... 8-9
- [3] vcc..... 8-10
- [4] aging..... 8-10
- [5] forward 8-11
- [6] topology..... 8-11
- [7] arp..... 8-11
- [8] flush..... 8-12
- [9] path-switch 8-12
- [10] completion..... 8-13
- [4] lec-control 8-14
- [5] reset..... 8-17
- [6] flood..... 8-17

Virtual LAN Menu

[6] vns	
..... [1] display	5-1
..... [4] ethernet	5-2
..... [5] atm	5-3

Network Management Menu

[7] management	
..... [1] ip	
..... [1] display	9-2
..... [4] ip-addr	9-2
..... [5] gateway	9-3
..... [6] mask	9-4
..... [2] snmp	
..... [1] display	9-4
..... [2] nms-addr	9-5

5

CONFIGURING VIRTUAL LANs

This chapter contains detailed descriptions of common management tasks for Virtual LANs (vLANs) connected to the 7600 Card. Please see “Virtual LANs in the 7600 Card” on page 12-18 for general background material concerning vLANs and how they are defined in the 7600 Card.

Connecting local Fast Ethernet segments to a vLAN over ATM is accomplished by connecting them to the 7600 Card bridge and ensuring that there is an internal ATM connection to an ELAN. For general information about bridges see “Bridges in the 7600 Card” on page 12-10. The following bridge configuration tasks are covered:

Configuring Bridges

- Display current bridge configuration 5-1
- Attach Fast Ethernet port to bridge 5-2
- Attach internal ATM port to bridge 5-3

Display Current Bridge Configuration

Displays the bridge configuration information for all bridges defined in the 7600 Card. For general information about bridges see “Bridges in the 7600 Card” on page 12-10.

Table 5-1 Task Actions

Menu Sequence	Enter	Result
[6] vns [1] display	None	Current bridge configuration parameters are displayed

Table 5-2 Bridge Configuration Parameters

Parameter	Description
Bridge	The bridge number
Fast Ethernet Ports	The Fast Ethernet ports assigned to the bridge.
ATM	<ul style="list-style-type: none"> ■ Yes: The internal ATM downlink port is assigned to the bridge (i.e., the bridge is connected to an ELAN) ■ No: The internal ATM downlink port is not assigned to the bridge
ELAN name	The ELAN name (if connected).

Example

Enter: [6] [1]

The following is displayed:

```

-----
| Bridge |      Ethernet ports      | ATM |      ELAN name (ATM)
+-----+-----+-----+-----+
| 0      | 1-2                      | YES | elan3576_0
| 1      | 3-4                      | YES | elan3576_1

```

Figure 5-1 Bridge Configuration Display

Attach Fast Ethernet Port to Bridge

Enter the bridge number and a Fast Ethernet port to attach a specific Fast Ethernet port to the bridge. The initial default configuration is a single bridge that includes all Fast Ethernet ports and an ATM connection. For general information about bridges see “Bridges in the 7600 Card” on page 12-10.

Table 5-3 Task Actions

Menu Sequence	Enter	Result
[6]vns	1 Bridge Number {0-3}	Specified Fast Ethernet port is attached to specified bridge
[4] ethernet	2 Fast Ethernet Port Number {1-4}	

Example

Enter: [6] [4] 1 3

Fast Ethernet port #3 is attached to bridge #1.

Attach Internal ATM Port to Bridge

Enter the bridge number and Y/N to attach/detach the internal ATM downlink port to an bridge. The initial default configuration is a single bridge that includes all Fast Ethernet ports and an ATM connection. For general information about bridges see "Bridges in the 7600 Card" on page 12-10.



The ATM port in context #1 must always be attached to bridge #0.

Table 5-4 Task Actions

Menu Sequence	Enter	Result
[6] vns	1 Bridge Number {0-3}	<ul style="list-style-type: none"> ■ Y: ATM port is attached to specified bridge ■ N: ATM port is detached from specified bridge
[5] atm	2 Y/N	

Example

Enter: [6] [5] 0 Y

The internal ATM port is attached to bridge #0.

6

FAST ETHERNET AND BRIDGE MANAGEMENT TASKS

This chapter contains detailed descriptions of common management tasks for Fast Ethernet LANs connected to the 7600 Card. Refer to Chapter 11 “*Ethernet LANs and Bridges in the 7400 Card*” for general background material concerning Ethernet LANs. The following tasks are covered:

Managing Fast Ethernet Ports

- Fast Ethernet Port Attributes and Statistics
- Disable a Fast Ethernet Port
- Display Broadcast Throttling Attributes
- Update Broadcast Threshold
- Enable/Disable Broadcast Throttling
- Update Fast Ethernet Port

Managing Ethernet Bridges

- Display Broadcast Throttling Attributes
- Update Bridge-aging- time
- Bridge-port Attributes and Statistics

Managing the Bridge Forwarding Database

- Display All Entries in Forwarding Database
- Display Learned Entries in Forwarding Database
- Display Static Entries in Forwarding Database
- Enter or Modify a Static Address in FDB
- Block a Static Address
- Remove a Static Address from FDB

Managing the Spanning Tree Protocol - Bridge-wide

- Display STP Enable Status
- Disable STP on Bridge
- Display Bridge STP Attributes
- Update Bridge-wide STP Parameters
- Update Bridge-priority
- Update Bridge-max-age
- Update Bridge-hello-time
- Update Bridge-forward- delay

Managing the Spanning Tree Protocol - per Bridge-port

- Display Bridge-port STP Attributes
- Disable Bridge-port
- Update Bridge-port STP parameters
- Update Bridge-port- priority
- Update Bridge-path-cost

Fast Ethernet Port Attributes and Statistics

Displays the Fast Ethernet port attributes and statistics for a specified Fast Ethernet port (see “Fast Ethernet Ports” on page 11-5 for general information about Ethernet ports).

Table 6-1 Task Actions

Menu Sequence	Enter	Result
[2] ethernet [1] display	Fast Ethernet port number {1-4}	Port attributes and statistics are displayed

Table 6-2 Ethernet Port Attributes

Name	Description
MAC Address	The MAC address uniquely identifying the Ethernet port.
Admin Status	The Port administrative status. <ul style="list-style-type: none"> ■ Up: Port is enabled by management ■ Down: Port is disabled by management
Oper Status	The Port operational status. <ul style="list-style-type: none"> ■ Up: Port is connected and operational ■ Down: Port is not connected or not operational

Table 6-3 Fast Ethernet Port Characteristics

Name	Description
Installed	Indicates whether Fast Ethernet port is installed: Yes or No
Type	Type of Fast Ethernet Port: Fx (Fiber) or Tx (Copper)
Mode	Auto-negotiation mode: <ul style="list-style-type: none"> ■ No auto-negotiation ■ All auto-negotiation ■ Duplex auto-negotiation ■ Speed auto-negotiation
Duplex	Transmission mode: Full or half duplex
Speed	Transmission speed: 10M or 100M

Table 6-4 Ethernet Port Statistics

Name	Description
In Octets	All octets received on the port.
In Ucast	Unicast frames received on the port excluding discards.
In Mcast	Multicast frames received on the port excluding discards.
In Bcast	Broadcast frames received on the port excluding discards.
In Discards	All frames received on the port and discarded for internal reasons, for example, queues.
In Errors	All frames received on the port and discarded due to errors.

Table 6-4 Ethernet Port Statistics (continued)

Name	Description
In Unknown	All frames received on the port and discarded due to unknown protocols.
Out Octets	All octets transmitted out of the port.
Out Ucast	Unicast frames transmitted out of the port including discards.
Out Mcast	Multicast frames transmitted out of the port including discards.
Out Bcast	Broadcast frames transmitted out of the port including discards.
Out Discards	All frames not transmitted out of the port for internal reasons.
Out Errors	All frames not transmitted out of the port due to errors.

Example

Enter: [2] [1] 1

The following information for Port #1 is displayed:

```

-----
Ethernet port 1:
=====
Mac address   : 00c0da1803c0
Installed    : Yes
Type         : Fx
Mode         : Non-Autonegotiation
Duplex       : Full
Speed        : 100M
Admin Status : Up
Oper Status  : Up

Statistics:
-----
In Octets   : 1188250808  Out Octets   : 19034810
In Ucast    : 0          Out Ucast    : 419
In Mcast    : 0          Out Mcast    : 0
In Bcast    : 0          Out Bcast    : 1
In Discards : 130        Out Discards : 0
In Errors   : 0          Out Errors   : 0
In Unknown  : 0
-----

```

Figure 6-1 Fast Ethernet Port Attributes and Statistics Display

Disable a Fast Ethernet Port

Disable or enable the Admin status of a Fast Ethernet port (see “Fast Ethernet Ports” on page 11-5 for general information about Ethernet ports).

Table 6-5 Task Actions

Menu Sequence	Enter	Result
[2] ethernet [2] status	1 Ethernet port number {1-4} 2 U(p)/D(own)	Administrative Status of Port is enabled or disabled

Example

Enter: [2] [2] 4 u

Ethernet Port 4 is enabled.

The following message is displayed on the screen:

```
Context #0 Event: Ethernet port #4 is Link Up
```

Display Broadcast Throttling Attributes

Displays broadcast throttling attributes. Broadcast throttling can be set for each port. When the number of broadcast frames through the port exceeds the high threshold, frames are discarded. When the number of broadcast frames goes below the low threshold the frames are retained.

Table 6-6 Task Actions

Menu Sequence	Enter	Result
[2] ethernet [3] bcast [1] display	None	Broadcast throttling attributes are displayed

Table 6-7 Broadcast Throttling Attributes

Name	Description
High threshold	The broadcast transmission rate limit above which broadcast frames are discarded (in frames/second).
Low threshold	The broadcast transmission rate limit below which broadcast frames are not discarded (in frames/second).

Table 6-7 Broadcast Throttling Attributes (continued)

Name	Description
Enable status	Broadcast throttling enabled/disabled for this port.

Example

Enter: [2] [3] [1]

The following is displayed:

```

-----
Port #1: high threshold 500 low threshold 300 Enabled
Port #2: high threshold 500 low threshold 300 Enabled
Port #3: high threshold 500 low threshold 300 Enabled
Port #4: high threshold 500 low threshold 300 Enabled

Broadcast throttling feature is enabled.
-----
    
```

Figure 6-2 Broadcast Throttling Attributes Display.

Update Broadcast Threshold

Updates broadcast attributes.

Table 6-8 Task Actions

Menu Sequence	Enter	Result
[2] ethernet	1 Ethernet port number {1-4}	The high and low thresholds are updated
[3] bcast	2 High Threshold	
[2] update	3 Low Threshold	

Example

Enter: [2] [3] [2] 4 500 300

The high and low thresholds for port 4 are updated.

Enable/Disable Broadcast Throttling

Disable or enable broadcast throttling for a specific port (see “Fast Ethernet Ports” on page 11-5 for general information about Ethernet ports). Entering “Enable” returns the previous threshold values.

Table 6-9 Task Actions

Menu Sequence	Enter	Result
[2] ethernet	1 Ethernet port number {1-4}	Broadcast throttling for the port is (e)nabled or (d)isabled
[3] bcast	2 D(isable)/E(nable)	
[3] state		

Example

Enter: [2] [3] [3] 4 E

Broadcast throttling for Port 4 is enabled.

Update Fast Ethernet Port

Updates Fast Ethernet port attributes. For more information see “Fast Ethernet Port Characteristics” on page 6-3 and see “Fast Ethernet Ports” on page 11-5.

The parameter inputs differ between the Tx (copper) and Fx (fiber) port types due to their different capabilities. The Fx port type permits only the entry of a fixed parameter for the duplex mode. The Tx port type allows selection of autonegotiation for speed and duplex mode individually. If one of these is not selected for autonegotiation it must be given a fixed parameter manually.

Table 6-10 Task Actions for Fx Port Type

Menu Sequence	Enter	Result
[2] ethernet	1 Ethernet port number {1-4}	The Fast Ethernet Fx port attributes are updated
[4] update	2 Duplex (H<alf>, F<ull>)	

Table 6-11 Task Actions for Tx Port Type

Menu Sequence	Enter	Result
[2] ethernet [4] update	1 Ethernet port number {1-4} 2 Auto mode (N<on-Auto>, A<ll>, D<uplx>, S<peed>) 3 *Speed (10,100) 4 †Duplex (H<alf>, F<ull>)	The Fast Ethernet Tx port attributes are updated.

* If "D" or "N" was entered in Step 2
 † If "S" or "N" was entered in Step 2

Example 1 - for Tx port type

Enter: [2] [4] 1 H

The Fast Ethernet Tx port #1 is set to half duplex.

Example 2 - for Fx port type

Enter: [2] [4] 1 D 10

The Fast Ethernet Tx port #1 is set to automode for duplex and a fixed speed of 10 Mbps.

Bridge Attributes and Statistics

Display the mapping of the bridge-ports to the Fast Ethernet ports on the 7600 Card as well as other bridge attributes and statistics. For more information about bridges in Ethernet LANs see "Transparent Bridges" on page 11-6.

Table 6-12 Task Actions

Menu Sequence	Enter	Result
[3] bridge [1] display	Bridge Number {0-3}	Bridge attributes and statistics are displayed

Table 6-13 Bridge Attributes and Statistics

Name	Description
Bridge Address	The MAC address uniquely identifying the logical bridge.
Bridge-port	The logical bridge-port number within the bridge.
Physical Port	The physical Ethernet port to which the logical bridge-port is mapped.
Aging Time	The bridge aging time.
Learned Discards	Addresses that should have been learned, but were discarded because of lack of space in the bridge's Forwarding Database.

Example

Enter: [3] [1] 0

The following is displayed.

```

-----
Bridge #0:
=====
Bridge address: 00c0da1803c0

Bridge STP is Disabled

| Bridge-port | Physical          |
+-----+
|      1      | Ethernet port 1  |
|      2      | Ethernet port 2  |
|      3      | Ethernet port 3  |
|      4      | Ethernet port 4  |
|      5      |      ATM port    |

Aging Time      : 900
Learned Discards : 0
-----

```

Figure 6-3 Bridge Attributes and Statistics Display

Update Bridge-aging-time

Update the bridge FDB parameter bridge-aging-time for a specified bridge. For more information about bridges in Ethernet LANs see “Transparent Bridges” on page 11-6.

Table 6-14 Task Actions

Menu Sequence	Enter	Result
[3] bridge	1 Bridge number {0-3}	The bridge FDB parameter bridge-aging-time for this bridge is updated.
[5] aging	2 Bridge-aging-time (secs)	

Example

Enter: [3] [5] 0 900

Sets the bridge-aging-time to 900 secs on bridge #0.

Bridge-port Attributes and Statistics

Displays the frame traffic statistics for a bridge-port. For more information about bridges in Ethernet LANs see “Transparent Bridges” on page 11-6.

Table 6-15 Task Actions

Menu Sequence	Enter	Result
[3] bridge	1 Bridge number {0-3}	Bridge-port attributes and statistics are displayed
[2] port	2 Bridge-port Number {1-5}	

Table 6-16 Bridge-port Attributes and Statistics

Name	Description
Bridge	The number of the bridge.
Port	The number of the bridge-port within the specified bridge.
Physical	The physical port to which the bridge-port is mapped.
In Frames	All frames received on the port excluding discards.
Out Frames	All frames transmitted out of the port, including discards.
In Discards	The number of frames received on the port, that were filtered by the forwarding process.

Table 6-16 Bridge-port Attributes and Statistics (continued)

Name	Description
Delay Exceeded Discards	The number of frames discarded by the port, due to excessive transit delay through the bridge.
Maximum Transfer Unit (MTU) Exceeded Discards	The number of frames discarded by the port, due to an excessive size.

Example

Enter: [3] [2] 0 1

The following is displayed:

```

-----
Bridge #0 Port 1:
=====

Physical: Ethernet port 1

In Frames           : 2
Out Frames          : 4
In Discards         : 0
Delay Exceeded Discards : 0
MTU Exceeded Discards : 0
-----

```

Figure 6-4 Bridge Attributes and Statistics Display

Display All Entries in Forwarding Database

Displays the complete Forwarding Database (FDB) for the specified bridge, including all addresses, the ports they are mapped to and their status. Each database entry is identified by an address. For more information about the Forwarding Database see “Forwarding Database” on page 11-7.

Table 6-17 Task Actions

Menu Sequence	Enter	Result
[3] bridge [3] fdb [1] display	1 Bridge number {0-3}	The contents of all address tables in the bridge FDB are displayed.

Table 6-18 Forwarding Database Fields

Name	Description
Addr	The MAC address to which the entry relates.
Port	The bridge-port related to the entry.
Status	Status: <ul style="list-style-type: none"> ■ <i>Management</i> - The port will always be zero. ■ <i>Self</i> - The bridge-ports' self-address. ■ <i>Learned</i> - Learned address.

Example

Enter: [3] [3] [1] 0

The following is displayed:

```
-----  
Addr: 0180c2000000 Port: 0 Status: Management  
Addr: 01c0da000200 Port: 0 Status: Management  
Addr: 0180c2000001 Port: 0 Status: Management  
Addr: 0180c2000002 Port: 0 Status: Management  
Addr: 0180c2000003 Port: 0 Status: Management  
Addr: 0180c2000004 Port: 0 Status: Management  
Addr: 0180c2000005 Port: 0 Status: Management  
Addr: 0180c2000006 Port: 0 Status: Management  
Addr: 0180c2000007 Port: 0 Status: Management  
Addr: 0180c2000008 Port: 0 Status: Management  
Addr: 0180c2000009 Port: 0 Status: Management  
Addr: 0180c200000a Port: 0 Status: Management  
Addr: 0180c200000b Port: 0 Status: Management  
Addr: 0180c200000c Port: 0 Status: Management  
Addr: 0180c200000d Port: 0 Status: Management  
Addr: 0180c200000e Port: 0 Status: Management  
Addr: 0180c200000f Port: 0 Status: Management  
Addr: aabbccddeeff Port: 0 Status: Management  
Addr: 0020af8dcd78 Port: 1 Status: Learned  
Addr: 00c0da1803c0 Port: 1 Status: Self  
Addr: 00c0da1803c1 Port: 2 Status: Self  
Addr: 00c0da1803c2 Port: 3 Status: Self  
Addr: 00c0da1803c3 Port: 4 Status: Self  
Addr: 00c0da1803c4 Port: 3 Status: Self  
Addr: 00c0da1803c5 Port: 2 Status: Self  
Addr: 00c0da1803cc Port: 4 Status: Self  
Addr: ffffffff Port: 0 Status: Management  
-----
```

Figure 6-5 Forwarding Database Display

Display Learned Entries in Forwarding Database

Displays only the learned entries in the Forwarding Database for the specified bridge. Each entry is identified by an address. For more information about learned entries in the Forwarding Database see “Learning Station Addresses” on page 11-7.

Table 6-19 Task Actions

Menu Sequence	Enter	Result
[3] bridge [3] fdb [2] learned	1 Bridge number {0-3}	The contents of the learned address table in the bridge FDB are displayed.

Table 6-20 Learned Forwarding Database Fields

Name	Description
Addr	The MAC address to which the entry relates.
Port	The bridge-port related to the entry.
Status	Status: Learned - Learned address.

Example

Enter: [3] [3] [2] 0

The following is displayed:

```

-----
Total number of learned FDB entries: 1.

Addr: 0020af8dcd78 Port: 1 Status: Learned
-----

```

Figure 6-6 Learned Forwarding Database Display

Display Static Entries in Forwarding Database

Displays only the static entries in the Forwarding Database for the specified bridge. These entries are either predefined or have been configured via management. For more information about static entries in the Forwarding Database see "Static Addresses" on page 11-8.

Table 6-21 Task Actions

Menu Sequence	Enter	Result
[3] bridge [3] fdb [3] static	1 Bridge number {0-3}	The contents of the static address table in the bridge FDB are displayed.

Table 6-22 Static Table Fields

Name	Description
Addr	The MAC address to which the entry relates.
Rcv-P	Allowed receive (input) port for this address. A zero in this field means that all ports are allowed.
Alwd-to	Allowed output port(s) for this address. The allowed-to information is displayed in binary form, with each digit referring to 5 bridge-ports. Refer to Table 6-22 for the Allowed-To Binary Table mapping.
M-ID	Member ID. If one of the destination ports is the ATM port, an ATM Member ID which is used to identify the ATM destination must be provided.
Stat	<p>The status of the entry:</p> <ul style="list-style-type: none"> ■ <i>Read-Only</i> - Predefined entries that may not be removed or updated. ■ <i>Permanent</i> - Permanent entries that will remain across system resets. ■ <i>Delete-On-Reset</i> - Temporary entries that will be deleted when the device is reset. ■ <i>Delete-On-Timeout</i> - Temporary entries that will be deleted after a specified period of time (aging time). ■ <i>Other-Bridge</i> - An entry with this address exists for a different bridge, and also affects this bridge. Entries of this type will always be defined such that a frame is flooded to all ports. These entries may not be removed or updated via this bridge. However, they may be removed or updated via the bridge they were defined for.

Static Addresses Allowed-to Binary Table

The Allowed-to field specifies where the frames arriving on a given address and bridge port must be forwarded to. This field consists of two nibbles, each of which is a hexadecimal number whose binary value signifies the bridge ports to be forwarded to within the specified bridge. Five bits are used, corresponding to the 5 bridge ports - 4 Fast Ethernet ports and 1 internal ATM port as shown in the following table.

Table 6-23 Hexadecimal Codes for Displaying Multiple Bridge Ports

Bridge Ports	Hex Value	Bridge Ports	Hex Value
1 2 3 4		5 x x x	
0 0 0 1	1	0 0 0 1	1
0 0 1 0	2	0 0 1 0	2
0 0 1 1	3	0 0 1 1	3
0 1 0 0	4	0 1 0 0	4
0 1 0 1	5	0 1 0 1	5
0 1 1 0	6	0 1 1 0	6
0 1 1 1	7	0 1 1 1	7
1 0 0 0	8	1 0 0 0	8
1 0 0 1	9	1 0 0 1	9
1 0 1 0	a	1 0 1 0	a
1 0 1 1	b	1 0 1 1	b
1 1 0 0	c	1 1 0 0	c
1 1 0 1	d	1 1 0 1	d
1 1 1 0	e	1 1 1 0	e
1 1 1 1	f	1 1 1 1	f

If, for example, the Allowed-to field is "f800", then the frames will be forwarded to bridge ports 1, 2, 3, 4, and 5. If the Allowed-to field is "1800" then the frames will be forwarded to bridge ports 4 and 5.

Example

Enter: [3] [3] [3] 0

The following is displayed:

```

-----
Addr: 0180c2000000 Rcv-P: 0 Alwd-to: fe00 M-ID: Stat: Read-Only
Addr: 01c0da000200 Rcv-P: 0 Alwd-to: 0000 M-ID: ---- Stat: Read-Only
Addr: 0180c2000001 Rcv-P: 0 Alwd-to: 0000 M-ID: ---- Stat: Read-Only
Addr: 0180c2000002 Rcv-P: 0 Alwd-to: 0000 M-ID: ---- Stat: Read-Only
Addr: 0180c2000003 Rcv-P: 0 Alwd-to: 0000 M-ID: ---- Stat: Read-Only
Addr: 0180c2000004 Rcv-P: 0 Alwd-to: 0000 M-ID: ---- Stat: Read-Only
Addr: 0180c2000005 Rcv-P: 0 Alwd-to: 0000 M-ID: ---- Stat: Read-Only
Addr: 0180c2000006 Rcv-P: 0 Alwd-to: 0000 M-ID: ---- Stat: Read-Only
Addr: 0180c2000007 Rcv-P: 0 Alwd-to: 0000 M-ID: ---- Stat: Read-Only
Addr: 0180c2000008 Rcv-P: 0 Alwd-to: 0000 M-ID: ---- Stat: Read-Only
Addr: 0180c2000009 Rcv-P: 0 Alwd-to: 0000 M-ID: ---- Stat: Read-Only
Addr: 0180c200000a Rcv-P: 0 Alwd-to: 0000 M-ID: ---- Stat: Read-Only
Addr: 0180c200000b Rcv-P: 0 Alwd-to: 0000 M-ID: ---- Stat: Read-Only
Addr: 0180c200000c Rcv-P: 0 Alwd-to: 0000 M-ID: ---- Stat: Read-Only
Addr: 0180c200000e Rcv-P: 0 Alwd-to: 0000 M-ID: ---- Stat: Read-Only
Addr: 0180c200000f Rcv-P: 0 Alwd-to: 0100 M-ID: 21 Stat: Read-Only
Addr: 0180c2000010 Rcv-P: 0 Alwd-to: f100 M-ID: 0 Stat: Read-Only
Addr: 0180c2000011 Rcv-P: 0 Alwd-to: 1100 M-ID: 23 Stat: Other-Brg
Addr: 0180c2000012 Rcv-P: 0 Alwd-to: f100 M-ID: 0 Stat: Del-On-TO
Addr: 0180c2000013 Rcv-P: 0 Alwd-to: 1100 M-ID: 24 Stat: Permanent
Addr: 0180c2000014 Rcv-P: 0 Alwd-to: f100 M-ID: 0 Stat: Read-Only
-----

```

Figure 6-7 Static Table Display

Enter or Modify a Static Address in FDB

Add a new static address to the FDB or update an existing one. The static entry is added to the Forwarding Database or updated with new destinations if it exists. A new entry is given a permanent status. Other status values may be given using an SNMP manager. For more information about static entries in the Forwarding Database see "Static Addresses" on page 11-8.

Table 6-24 Task Actions

Menu Sequence	Enter	Result
[3] bridge	1 Bridge number {0-3}	If the station address does not exist in the static address table of the FDB, it is added to it and receives the permanent status. If the address already exists, the ports are updated if they are different from those specified.
[3] fdb	2 Station address (MAC address)	
[4] allow	3 Input bridge-port number {0-5, (0 for all ports)}	
	4 Output bridge-port number(s) {1-5} and Member ID (for the ATM port)	

Example

Enter: [3] [3] [4] 0 0180c2000000 1 2

In the static Forwarding Database of bridge #0, the MAC address 0180c2000000 is allowed for input bridge-port #1 and output bridge port #2.

Block a Static Address

Specify bridge-ports on which communication is blocked for a static address in the FDB. For more information about static entries in the Forwarding Database see "Static Addresses" on page 11-8.

The blocked input and output bridge ports are specified by single hexadecimal numbers as in Table 6-20.

Table 6-25 Task Actions

Menu Sequence	Enter	Result
[3] bridge	1 Bridge number {0-4}	Communication is blocked on the specified ports for the static station address specified.
[3] fdb	2 Station address (MAC address)	
[5] block	3 Input bridge-port number {0-5}, (0 for all ports)}	
	4 Output bridge-port number(s) {1-5} or Member ID (for the ATM port)	

Example

Enter: [3] [3] [5] 0 0180c2000000 1 4

In the static Forwarding Database of bridge #0, the MAC address 0180c2000000 is blocked for input bridge-port #1 and output bridge ports #4.

Remove a Static Address from FDB

Specify a bridge number, Ethernet MAC address, and bridge-port number of the static entry (address) that you want to remove from the Forwarding Database. For more information about static entries in the Forwarding Database see "Static Addresses" on page 11-8.

Table 6-26 Task Actions

Menu Sequence	Enter	Result
[3] bridge	1 Bridge number {0-3}	The station address is removed from the static address table of the FDB.
[3] fdb	2 Station address (MAC address)	
[6] remove	3 Input bridge-port number {0-5}, (0 for all ports)}	

Example

Enter: [3] [3] [6] 0 0180c2000000 1

In the static Forwarding Database of bridge #0, the MAC address **0180c2000000** is removed for input bridge-port #1.

Display STP Enable Status

Display STP enable status for all bridges. For general information about the STP see “Spanning Tree Protocol” on page 11-8. For more information about the STP enable status see “Disabling the STP” on page 11-10.

Table 6-27 Task Actions

Menu Sequence	Enter	Result
[3] bridge [4] stp [1] display	None	The STP enable/disable status is displayed for this bridge.

Example

Enter: [3] [4] [1]

The following is displayed:

```

      STP Status
      -----
      Bridge #0: STP is Disabled
  
```

Figure 6-8 STP Enable Status Display

Disable STP on Bridge

Disable and enable the STP on a specified bridge. For more information about the STP enable status see “Disabling the STP” on page 11-8.

Table 6-28 Task Actions

Menu Sequence	Enter	Result
[3] bridge [4] stp [4] status	1 Bridge number {0-3} 2 D(isable)/E(nable)	(D)isables or (E)nables STP on this bridge.

Example

Enter: [3] [4] [4] 0 D

Disables the STP on bridge 0 and produces the following message:

Bridge #0: STP is now disabled.

Display Bridge STP Attributes

Display all STP attributes for a specified bridge. For general information about the STP and about the STP parameters see “Spanning Tree Protocol” on page 11-6.

Table 6-29 Task Actions

Menu Sequence	Enter	Result
[3] bridge [4] stp [2] bridge [1] display	1 Bridge number {0-3}	The STP attributes are displayed for this bridge.

Table 6-30 Bridge STP Attributes

Parameter	Description
Bridge-Protocol	The STP version (as in IEEE 802.1D).
Bridge-Priority	A 2-octet value that allows the network manager to influence the choice of root bridge and the designated bridge.
Bridge-Topology-Changes	The number of topology changes which have occurred since the bridge was last reset.
Bridge-Designated-Root	The bridge assumed to be the root bridge.
Root-Cost	The cost of the path from this bridge to the root bridge.
Root-Port	The port that offers the lowest cost path to the root bridge.
Max-Age	The message age value at which a stored CBPDU is discarded.
Hello-Time	The time interval between the transmission of CBPDUs.
Forward-Delay	The time spent in the listening and the learning state while the Spanning tree is re-configuring.

Table 6-30 Bridge STP Attributes (continued)

Parameter	Description
Hold-Time	A fixed bridge parameter specifying the minimum time period elapsing between the transmission of <i>CBPDUs</i> through a given bridge-port. No more than two <i>CBPDUs</i> shall be transmitted in any Hold-Time period.
Bridge-Max-Age	The value of the Max-Age parameter when the bridge is, or is attempting to become, the Root.
Bridge-Hello-Time	The value of the Hello-Time parameter when the bridge is, or is attempting to become, the Root.
Bridge-Forward-Delay	The value of the Forward-Delay parameter when the bridge is, or is attempting to become, the root bridge.

Example

Enter: [3] [4] [2] [1] 0

The STP attributes for bridge #0 is displayed as follows:

```

                bridge #0 STP Attributes:
                =====
bridge STP is Disabled.
bridge Protocol= 3
bridge Priority= 32768
bridge Topology Changes= 4
bridge Designated Root= 800000c0da1800a0
Root Cost= 0
Root Port= 0
bridge Time Since Topology Change= 16313875
Max-Age= 2000
Hello Time= 200
Forward Delay= 1500
Hold Time= 100
bridge Max-Age= 2000
bridge Hello Time= 200
bridge Forward Delay= 1500

```

Figure 6-9 Bridge STP Attributes Display

Update Bridge-wide STP Parameters

Update bridge STP parameters: bridge-priority, bridge-max-age, bridge-hello-time, and bridge-forward-delay (see “Management Bridge Parameters” on page 11-8 for more information about the STP parameters).

Update Bridge-priority

Update the STP parameter bridge-priority for a specified bridge.

Table 6-31 Task Actions

Menu Sequence	Enter	Result
[3] bridge [4] stp [2] bridge [2] priority	1 Bridge number {0-3} 2 Bridge-priority	The STP parameter bridge-priority for this bridge is updated.

Example

Enter: [3] [4] [2] [2] 0 32768

The bridge-priority for bridge #0 is set to 32768

Update Bridge-max-age

Update the STP parameter bridge-max-age for a specified bridge.

Table 6-32 Task Actions

Menu Sequence	Enter	Result
[3] bridge [4] stp [2] bridge [3] max-age	1 Bridge number {0-3} 2 Bridge-max-age (secs)	The STP parameter bridge-max-age for this bridge is updated.

Example

Enter: [3] [4] [2] [3] 0 2000

The bridge-max-age for bridge #0 is set to 2000 secs.

Update Bridge-hello-time

Update the STP parameter bridge-hello-time for a specified bridge.

Table 6-33 Task Actions

Menu Sequence	Enter	Result
[3] bridge	1 Bridge number {0-3}	The STP parameter bridge-hello-time for this bridge is updated.
[4] stp	2 Bridge-hello-time	
[2] bridge		
[4] hello		

Example

Enter: [3] [4] [2] [4] 0 2000

The bridge-hello-time for bridge #0 is set to 2000 secs.

**Update
Bridge-forward-
delay**

Update the STP parameter bridge-forward-delay for a specified bridge.

Table 6-34 Task Actions

Menu Sequence	Enter	Result
[3] bridge	1 Bridge number {0-3}	The STP parameter bridge-forward-delay for this bridge is updated.
[4] stp	2 Bridge-forward-delay	
[2] bridge		
[5] forward		

Example

Enter: [3] [4] [2] [5] 0 1500

The bridge-forward-delay for bridge #0 is set to 1500 secs.

Display Bridge-port STP Attributes

Display all STP attributes for a specified bridge-port.

Table 6-35 Task Actions

Menu Sequence	Enter	Result
[3] bridge [4] stp [3] port [1] display	1 Bridge number {0-3} 2 Bridge-port number {0-5}, (0 for all ports)}	The STP attributes are displayed for this bridge-port.

Table 6-36 Bridge-port STP Attributes

Parameter	Description
Bridge-Port-Priority	A 1-octet value that allows the network manager to influence the choice of port when a bridge has two ports connected in a loop.
Bridge-Port-State	The current state of the port: <i>Disabled</i> , <i>Listening</i> , <i>Learning</i> , <i>Forwarding</i> , or <i>Blocking</i> .
Bridge-Port-Path-Cost	The cost to be added to the root-path-cost field to determine the cost of the path to the root through this port.
Bridge-Port-Designated-Root	ID of the bridge in the root-identifier parameter transmitted by the designated-Bridge for the LAN to which the port is attached.
Bridge-Port-Designated-Cost	Cost of the path to the root-bridge offered by the designated-port on the LAN to which this port is attached.
Bridge-Port-Designated-Bridge	ID of the bridge assumed to be the designated-bridge for the LAN associated with the port. The parameter is used: (a) together with the designated-port and port-identifier parameters for the port to ascertain whether this port should be the designated-port for the LAN to which it is attached; (b) to test the value of the bridge Identifier parameter conveyed in received CBPDUs.
Bridge-Port-Designated-Port	The port-identifier of the bridge-port assumed to be the designated-port for the LAN associated with the port. The parameter is used: (a) together with the designated-bridge and port-identifier parameters for the Port to ascertain whether this Port should be the designated-port for the LAN to which it is attached; (b) by management to determine the topology of the bridged Local Area Network..

Example

Enter: [3] [4] [3] [1] 0 1

The attributes of port #1 of bridge #0 are displayed as follows:

```

bridge #0 port #1 STP Attributes:
=====

Bridge-port Priority= 128
Bridge-port State= forwarding
Bridge-port Path Cost= 100
Bridge-port Designated Root= 800000c0da1800a0
Bridge-port Designated Cost= 0
Bridge-port Designated Bridge= 800000c0da1800a0
Bridge-port Designated port= 8001
Bridge-port Forward Transitions= 1
    
```

Figure 6-10 Bridge-port STP Attributes Display.

Disable Bridge-port Disable and enable a bridge-port for a specified bridge for management.

Table 6-37 Task Actions

Menu Sequence	Enter	Result
[3] bridge	1 Bridge number {0-3}	(D)isable or (e)nables this bridge-port for management.
[4] stp	2 Bridge-port Number {1-5}	
[3] port	3 D(isable)/E(nable)	
[4] status		

Example

Enter: [3] [4] [3] [4] 0 1 D

Disables bridge-port 1 on bridge 0.

Update Bridge-port STP parameters Update bridge-port STP parameters: bridge-port-priority and bridge-path-cost (see "Management Bridge Parameters" on page 11-8 for more information about the STP parameters).

Update Bridge-port-priority Update the STP parameter bridge-port-priority for a specified bridge.

Table 6-38 Task Actions

Menu Sequence	Enter	Result
[3] bridge	1 Bridge number {0-3}	The STP parameter bridge-port-priority for this bridge-port is updated.
[4] stp	2 Bridge-port Number {1-5}	
[3] port		
[2] priority	3 Bridge-port-priority	

Example

Enter: [3] [4] [3] [2] 0 1 128

The bridge-port-priority for port #1 of bridge #0 is set to 128.

**Update
Bridge-path-cost**

Update the STP parameter bridge-path-cost for a specified bridge.

Table 6-39 Task Actions

Menu Sequence	Enter	Result
[3] bridge	1 Bridge number {0-3}	The STP parameter bridge-path-cost for this bridge-port is updated.
[4] stp	2 Bridge-port Number {1-5}	
[3] port		
[3] cost	3 Bridge-path-cost	

Example

Enter: [3] [4] [3] [3] 0 1 100

The bridge-path-cost for port #1 of bridge #0 is set to 100.

7

MANAGING ATM RESOURCES

This chapter contains detailed descriptions of common management tasks for the internal ATM port of the 7600 Card. Please see "Bridges in the 7600 Card" on page 12-10 for general background material concerning how the internal ATM port connects a bridge to the ATM network in the 7600 Card.

The following internal ATM port management tasks are covered:

Manage ATM port

- Display ATM Port Attributes and Statistics
- Enable/Disable ATM Port Admin Status

Manage Bridge ATM addresses

- Display Bridge ATM address
- Update Bridge ATM Address

Manage Traffic Management

- Display TM Configuration
- Enable TM
- Display TM Clients
- Add TM Client
- Remove TM Client

Update ATM parameters

- Update UNI Version

Display ATM Port Attributes and Statistics

Displays the internal ATM port attributes and statistics (refer to Table 7-2)

Table 7-1 Task Actions

Menu Sequence	Enter	Result
[4] atm [1] display	None	Internal ATM port attributes and statistics are displayed

Table 7-2 ATM Port Attributes and Statistics

Parameter	Description
Admin Status	The port status ("up" or "down") defined administratively using the Administration Console or SNMP Manager. If the port is administratively down, it will stay operationally down.
Oper Status	The operational status of the port ("up" or "down"). A down status may be caused by the port being administratively down.
In Octets (ATM Layer)	All octets received on the ATM port to the ATM layer excluding Physical layer discards.
In Ucast (ATM Layer)	All cells received on the ATM port to the ATM layer excluding Physical and ATM layer discards.
In Octets (AAL5 Layer)	All octets received on the ATM port to the AAL5 layer excluding Physical and ATM layer discards.
In Ucast (AAL5 Layer)	All AAL5 frames received on the ATM port excluding Physical, ATM and AAL5 layer discards.
Out Ucast (AAL5 Layer)	All AAL5 frames transmitted from the AAL5 layer including AAL5, ATM and Physical layer discards.

Example

Enter: [4] [1]

The following sample ATM statistics report is displayed.

```

-----
ATM port:
=====
Admin Status : Up
Oper Status  : Up

UNI Version  3.0

ATM Layer statistics:
-----
In Octets    : 2619649815          In Ucast    : 49427355

AAL5 Layer statistics:
-----
In Octets    : 2372513040          In Ucast    : 24705762
Out Ucast    :                    : 25826096
-----

```

Figure 7-1 ATM Statistics Report Display.

Display Bridge ATM address

Displays the current ATM addresses of the bridges.

Table 7-3 Task Actions

Menu Sequence	Enter	Result
[4] atm	None	ATM addresses of the bridges are displayed
[2] address		
[1] display		

Table 7-4 ATM Address Fields

Field	Description
Bridge	The bridge number.
ATM Address	The ATM address assigned to the bridge.

Table 7-4 ATM Address Fields

Field	Description
Source	<p>The source of the ATM addresses:</p> <ul style="list-style-type: none"> ■ Automatically assigned by ILMI ■ Manually assigned and saved in flash memory <p>In order to use ILMI automatically, this value should not be assigned manually.</p>
State (in ILMI)	<p>State of the ATM address within ILMI. If no address has been manually assigned, ILMI is automatically used. In this case, it should normally be in the Registered state.</p>

Example

Enter: [4] [2] [1]

The following is a sample ATM address display:

Bridge	ATM Address	Source	State
		(in ILMI)	
0	47000000090000000000000000000000c0da18050c00	ILMI	*REGISTERD*

Figure 7-2 ATM Address Display**Update Bridge ATM Address**

Enter the bridge number and the ATM address (or "!" to invalidate the ATM address) to update the local ATM address. An ATM address entered by this command will override the ILMI address registration for the specified bridge. When you change the ATM address manually it must be coordinated with the ATM switch. Use the invalidate command ("!") to reset the ATM address, so as to restore the automatic ILMI address registration for the specified bridge.

Table 7-5 Task Actions

Menu Sequence	Enter	Result
[4] atm	1 Bridge Number {0-3}	<ul style="list-style-type: none"> ■ ATM address: Updates ATM address of the bridges. ■ "!" : Restores the automatic ILMI address registration for this bridge.
[2] address	2 ATM Address or "!"	
[4] change		

Example

Enter: [4] [2] [4] 0!

Restores the automatic ILMI address registration for bridge #0.

Display TM Configuration

Displays the Traffic Management configuration. Refer to Chapter 13 for more information about Traffic Management in the 7600 Card.

Table 7-6 Task Actions

Menu Sequence	Enter	Result
[4] atm [4] tm [1] display	None	The Traffic Management configuration is displayed.

Example

Enter: [4] [4] [1]

The following is a sample Traffic Management configuration display:

```

-----
Traffic Management Configuration

TM State is DISABLED.
TM TRAM update is DISABLED.
Dual rate mechanism is ENABLED.
Default profile                is 1
Default profile for single users is 2
Operational profile           is 3
Operational profile for single users is 4
-----

```

Figure 7-3 Traffic Management configuration display

Enable TM

Enable Traffic Management operation. The application of this menu item toggles TM operation on and off.

Table 7-7 Task Actions

Menu Sequence	Enter	Result
[4] atm [4] tm [2] enable	None	The Traffic Management configuration is displayed.

Example

Enter: [4] [4] [2]

The state of TM is changed from enabled to disabled and vice versa.

Display TM Clients

Display Traffic Management remote Client Database. The database entries are listed in the following table.

Table 7-8 Characteristics of TM Remote Client Database

Characteristic	Range	Default	Meaning
Entry	1-64		Index of Client in database
TM enabled	Y/N	Y	TM enable flag
DD connection	Y/N	Y	Direct-data connection
Remote client ATM address			ATM address of client in database
Profile	1-32	3	Index of lookup table used to determine data transmission rates
TM Peak rate	0-1.55e+08	1.55e+08	Peak data transmission rate in bps

Table 7-9 Task Actions

Menu Sequence	Enter	Result
[4] atm [4] tm [3] client [1] display	None	The Traffic Management remote Client Database is displayed.

Enter: [4] [4] [3] [1]

The TM remote Client Database is displayed as follows:

```

-----
TM Remote Client Data Base

Entry: 1
TM is:  ENABLE
Connection Type:  DD
ATM address:  47.00.00.00.11.22.33.44.55.66
Profile:  3
TM rate bps:  1.55e +08
-----

```

Figure 7-4 TM Remote Client Database Display

Add TM Client

Add Traffic Management client to remote Client Database. For more information see “Display TM Clients” on page 7-6.

Table 7-10 Task Actions

Menu Sequence	Enter	Result
[4] atm	1 ATM address	Client is added to the Traffic Management remote Client Database.
[4] tm	2 Profile (1-32)	
[3] client	3 TM peak rate	
[2] add	4 TM enable (Y/N)	

Example

Enter: [4] [4] [3] [2] + [respond to prompts]

Characteristics for the new client in the Traffic Management remote Client Database are requested as follows:

```
Remote client ATM address:
Profile (1-32)
TM Peak rate:
TM enable (Y/N)? :
DD connection
Entry added
```

Remove TM Client

Remove Traffic Management client from remote Client Database.

Table 7-11 Task Actions

Menu Sequence	Enter	Result
[4] atm	Entry (1-64, 0=all)	Client with specified entry number is removed from the Traffic Management remote Client Database.
[4] tm		
[3] client		
[3] remove		

Example

Enter: [4] [4] [3] [3] 1

Entry #1 is removed from the remote Client Database

Update UNI Version Choose between working with UNI 3.0 and UNI 3.1 versions.

Table 7-12 Task Actions

Menu Sequence	Enter	Result
[4] atm	3.0 or 3.1	The selected version is saved in flash
[6] uni		

Example

Enter: [4] [6]

The following screen prompt is displayed. The currently active version is displayed after the colon. Either press return to keep the same version or type in the other version.

```
Select UNI version (3.0, 3.1) : 3.0
```

The selected version is saved in flash.

Enable/Disable ATM Port Admin Status Enable or disable the ATM port for all bridges. Setting the port to “down” will cause the port to be (and stay) operationally down. Specify “up” to enable the ATM port or “down” to disable the ATM port.

Table 7-13 Task Actions

Menu Sequence	Enter	Result
[4] atm	(U)p/(D)own	■ Up: Enables ATM port
[8] status		■ Down: Disables ATM port

Example

Enter: [4] [8] u

ATM port is enabled. The following screen message is displayed:

```
Context #0 Event: ATM port Link Up.
```

8

MANAGING LAN EMULATION CLIENTS

This chapter contains detailed descriptions of common management tasks for the LAN Emulation Client of the 7600 Card. For a general discussion of LAN Emulation, see "LAN Emulation Overview" on page 12-5 and see "Bridges in the 7600 Card" on page 12-10 for material describing how the LAN Emulation Client connects a bridge to the ATM network Emulated LAN in the 7600 Card.

The following LAN Emulation Client (LEC) management tasks are covered:

Display statistics

- Display LEC Statistics
- Display LEC Control-frame Statistics
- Reset LEC Control-frame Statistics

Manage configuration parameters

- Display Current LEC Configuration
- Update LECS Address
- Update ELAN Name
- Update LES Address

Manage operational parameters

- Display LEC Operational Parameters
- Update LEC Operational Parameters
- Control-timeout
- VCC-timeout-period
- Aging-time
- Forward-delay-time

- Topology-change- flag
- Expected LE_ARP response-time
- Flush-timeout
- Path-switching- delay
- Connection- completion-timer

Manage data-frame parameters

- Update Unknown Unicast-flood- Mode

Display LEC Statistics

Displays the LAN Emulation Client (LEC) connection state and statistics for the specified bridge (refer to Table 8-2). For more information see “Data Transmission over an ELAN” on page 12-15.

Table 8-1 Task Actions

Menu Sequence	Enter	Result
[5] le [1] display	1 Bridge Number {0-3}	LAN Emulation Client (LEC) connection state and statistics for the specified bridge are displayed.

Table 8-2 LEC Attributes

Attribute	Description
State	The connection state of the LEC is one of the following: <ul style="list-style-type: none"> ■ Initial State ■ LECs Connect ■ Configure ■ Join ■ Bus Connect ■ Operational
In* Octets	All octets of LE frames received by the LEC.
In Ucast	Unicast LE frames received by the LEC targeted to the device, excluding Physical, ATM and AAL5 layer discards.
In Mcast	Multicast LE frames received by the LEC targeted to the device, excluding Physical, ATM and AAL5 layer discards.
In Bcast	Broadcast LE frames received by the LEC targeted to the device, excluding Physical, ATM and AAL5 layer discards.

Table 8-2 LEC Attributes (continued)

Attribute	Description
In Discards	All LE frames received by the LEC, discarded for internal reasons, for example, queues.
In Errors	All LE frames received by the LEC, discarded due to errors.
In Unknown	All LE frames received by the LEC, discarded due to unknown protocols.
Out Octets	All octets of LE frames transmitted by the LEC.
Out Ucast	Unicast LE frames transmitted from the LEC initiated by the device, including LE, AAL5, ATM and Physical layer discards.
Out Mcast	Multicast LE frames transmitted from the LEC initiated by the device, including LE, AAL5, ATM and Physical layer discards.
Out Bcast	Broadcast LE frames transmitted from the LEC initiated by the device, including LE, AAL5, ATM and Physical layer discards.
Out Discards	All LE frames initiated by the device, discarded from being transmitted out the LEC for internal reasons, for example, queues.
Out Errors	All LE frames initiated by the device, discarded from being transmitted out the LEC due to errors.

* In - from the ATM

Example

Enter: [5] [1] 0

The following connection state and statistics for the bridge #0 are displayed:

```

-----
LEC of bridge 0:
=====
State: Operational

Statistics:
-----
In Octets      :      237251304          Out Octets      :              0
In Ucast       :              0          Out Ucast       :              0
In Mcast       :              0          Out Mcast       :              0
In Bcast       :              0          Out Bcast       :              1
In Discards    :              0          Out Discards    :              0
In Errors      :              0          Out Errors      :              0
In Unknown     :              0
-----

```

Figure 8-1 LEC Attributes Display

Display Current LEC Configuration

Displays the current LEC configuration and status, including LECS, LES and BUS information (refer to Table 8-4). For general information about LECs see “LAN Emulation Overview” on page 12-5.

Table 8-3 Task Actions

Menu Sequence	Enter	Result
[5] le [2] config [1] display	1 Bridge Number {0-3}	Displays the current LEC configuration and status for the specified bridge.

Table 8-4 LEC Configuration and Status Information

LECS Information	Description
ATM Address	The ATM address of the LECS.
Config VCC	VPI/VCI values of the configuration-direct VCC.
LES Information	Description
ELAN Name	The name of the Emulated LAN (ELAN) to which the LEC belongs.
LEC ID	The LAN Emulation Client (LEC) identifier.
ATM Address	ATM address of the LES.

Table 8-4 LEC Configuration and Status Information (continued)

Control Direct VCC	VPI/VCI values of the control-direct VCC from the LEC to the LES.
Control Distribute VCC	VPI/VCI values of the control-distribute VCC from the LES to the LEC.
BUS Information	Description
ATM Address	ATM address of the BUS.
Multicast Send VCC	VPI/VCI values of the multicast-send VCC from the LEC to the BUS.
Multicast Forward VCC	VPI/VCI values of the multicast-forward VCC from the BUS to the LEC.

Example

Enter: [5] [2] [1] 0

The following LEC configuration and status for the bridge #0 are displayed.

```

-----
| LECS via ILMI mode is : Disabled
| LECS info :
| ATM address: not valid
| Config VCC          (VPI/VCI) : not valid
+-----+
| LES info :
| ELAN name : elan0_0 lec id : 6
| ATM address: 47000000090000000000000000000000c0da60000000
| Control Direct VCC (VPI/VCI) : 0 / 40
| Control Distribute VCC(VPI/VCI) : 0 / 36
+-----+
| BUS info :
| ATM address: 47000000090000000000000000000000c0da60000000
| Multicast Send VCC (VPI/VCI) : 0 / 41
| Multicast Forward VCC (VPI/VCI) : 0 / 37
-----

```

Figure 8-2 LEC Configuration and Status Display

Update LECS Address

Enter the bridge number and ATM address (or “!” to invalidate the address) to update the LECS address. For general information about LECS see “LAN Emulation Overview” on page 12-5.

Table 8-5 Task Actions

Menu Sequence	Enter	Result
[5] le	1 Bridge Number {0-3}	<ul style="list-style-type: none"> ■ ATM address: Updates the specified LECS ATM address for specified bridge ■ “!”: Invalidates the LECS ATM address
[2] config	2 LECS ATM address or “!”	
[4] cs-addr		

Example

Enter: [5][2][4] 0 47000000090000000000000000000000c0da60000000

The LECS address for the LEC of bridge #0 is entered.

Update ELAN Name

Enter: the bridge number and ELAN name (or “!” to invalidate the name) to update the ELAN name. For general information about LECs see “LAN Emulation Overview” on page 12-5.

Table 8-6 Task Actions

Menu Sequence	Enter	Result
[5] le	1 Bridge Number {0-3}	<ul style="list-style-type: none"> ■ ELAN name: Updates the specified ELAN name for specified bridge to flash ■ “!”: Invalidate the ELAN name
[2] config	2 ELAN name or “!”	
[5] elan-name		

Example

Enter: [5][2][5] 0 ELAN_0

The ELAN name for the LEC of bridge #0 is entered.

Update LES Address Enter the bridge number and ATM address (or ! to invalidate the address) to update the LES address. For general information about LECs see “LAN Emulation Overview” on page 12-5.

Table 8-7 Task Actions

Menu Sequence	Enter	Result
[5] le	1 Bridge Number {0-3}	<ul style="list-style-type: none"> ■ ATM address: Update the specified LES ATM address for specified bridge ■ “!”: Invalidates the LES ATM address
[2] config [6] les-addr	2 LES ATM address or “!”	

Example

Enter: [5][2][4] 0 4700000009000000000000000000c0da60000000

The LES address for the LEC of bridge #0 is entered.

Enable LECS Address via ILMI

Enable the option to obtain the LECS address via the ILMI. Each application of the command toggles the option on or off. The change will take place after the next reset. For general information about LECSs see “LAN Emulation Overview” on page 12-5.

Table 8-8 Task Actions

Menu Sequence	Enter	Result
[5] le [2] config [7] mode-lecs	None	<ul style="list-style-type: none"> ■ The option to obtain the LECS address via ILMI is toggled on or off. The default is off.

Example

Enter: [5][2][7]

The option to obtain the LECS address via ILMI is toggled on or off.

Display LEC Operational Parameters

Displays the LEC operational parameters for the specified bridge (refer to Table 8-10). For more information see “LEC Parameters” on page 12-16.

Table 8-9 Task Actions

Menu Sequence	Enter	Result
[5] le [3] operational [1] display	1 Bridge Number {0-3}	LEC operational information for the specified bridge is displayed.

Table 8-10 LEC Operational Parameters

LEC Parameter	Description
Control-timeout	Timeout period used for timing out most request/response control frame interactions.
VCC-timeout-period	An LEC should release any Data Direct VCC that has not been used to transmit or receive any data frames for the length of the VCC-timeout-period.
Aging-time	The maximum time that an LEC will maintain an entry in its LE_ARP cache in the absence of a verification of that relationship.
Forward-delay-time	The maximum time that an LEC will maintain an entry for a non-local MAC address in its LE_ARP cache in the absence of a verification of that relationship, as long as the topology-change-flag is true.
Expected LE_ARP Resp Time	The maximum time that the LEC expects an LE_ARP request/response cycle to take. Used for retries and verifies.
Topology-change-flag	Boolean indication that the LEC is using the forward-delay-time instead of aging-time to age non-local entries in its LE_ARP cache.
Flush-timeout	Time limit to wait to receive an LE_FLUSH response after the request has been sent, before taking recovery action.
Path-switching-delay	The time since sending a frame to the BUS after which the LEC may assume that the frame has been either discarded or delivered to the recipient.
Connection-completion-timer	In Connection Establishment this is the time period in which data or a READY_IND message is expected from a Calling Party.

Example

Enter: [5][3][1] 0

The LEC operational information for the LEC of bridge #0 is displayed as follows:

```

-----
Control Timeout= 120
VCC Timeout= 1200
Aging Time= 300
Forward Delay Time= 15
Expected LE ARP Resp Time= 1
Topology change flag= OFF
Flush Timeout= 4
Path Switching Delay= 6
Connection Completion Timer= 4
-----

```

Figure 8-3 LEC Operational Parameters Display

Update LEC Operational Parameters

Update the LEC operational parameters: control-timeout, VCC-timeout-period, aging-time, forward-delay-time, topology-change-flag, expected LE_ARP response-time, flush-timeout, path-switching-delay and connection-completion-timer. For more information see "LEC Parameters" on page 12-16.

Control-timeout

Enter the bridge number and control-timeout value to update the control-timeout parameter in seconds.

Table 8-11 Task Actions

Menu Sequence	Enter	Result
[5] le	1 Bridge Number {0-3}	The control-timeout parameter is updated for the specified bridge.
[3] operational	2 Control-timeout {10-300}	
[2] control		

Example

Enter: [5][3][2] 0 100

The control-timeout parameter for the LEC of bridge #0 is updated to 100 seconds.

VCC-timeout-period Enter the bridge number and control-timeout value to update the VCC-timeout-period parameter.

Table 8-12 Task Actions

Menu Sequence	Enter	Result
[5] le	1 Bridge Number {0-3}	The VCC-timeout-period parameter is updated for the specified bridge. Minimum=None specified Default=20 minutes Maximum=Unlimited
[3] operational	2 VCC-timeout-period {minutes}	
[3] vcc		

Example

Enter: [5][3][3] 0 20

The VCC-timeout-period parameter for the LEC of bridge #0 is updated to 20 minutes.

Aging-time Enter the bridge number and aging-time value to update the LEC aging-time parameter.

Table 8-13 Task Actions

Menu Sequence	Enter	Result
[5] le	1 Bridge Number {0-3}	The LEC aging-time parameter is updated for the specified bridge.
[3] operational	2 LEC aging-time {10-300}	
[4] aging		

Example

Enter: [5][3][4] 0 250

The aging-time parameter for the LEC of bridge #0 is updated to 250 seconds.

Forward-delay-time Enter the bridge number and forward-delay-time value to update the LEC forward-delay-time parameter.

Table 8-14 Task Actions

Menu Sequence	Enter	Result
[5] le	1 Bridge Number {0-3}	The LEC forward-delay-time parameter is updated for the specified bridge.
[3] operational	2 LEC forward-delay-time {4-30}	
[5] forward		

Example

Enter: [5][3][5] 0 20

The forward-delay-time parameter for the LEC of bridge #0 is updated to 20 seconds.

Topology-change-flag Enter the bridge number and topology-change-flag value to update the LEC topology-change-flag parameter.

Table 8-15 Task Actions

Menu Sequence	Enter	Result
[5] le	1 Bridge Number {0-3}	The LEC topology-change-flag parameter is updated for the specified bridge.
[3] operational	2 LEC topology-change-flag	
[6] topology		

Example

Enter: [5][3][6] 0 ON

The topology-change-flag parameter for the LEC of bridge #0 is updated to ON.

Expected LE_ARP response-time Enter the bridge number and expected LE_ARP response-time value to update the LEC expected LE_ARP response-time parameter.

Table 8-16 Task Actions

Menu Sequence	Enter	Result
[5] le	1 Bridge Number {0-3}	The LEC expected LE_ARP response-time parameter is updated for the specified bridge.
[3] operational	2 LEC expected LE_ARP response-time {1-30}	
[7] arp		

Example

Enter: [5][3][7] 0 2

The expected LE_ARP response-time parameter for the LEC of bridge #0 is updated to 2 seconds.

Flush-timeout

Enter the bridge number and flush-timeout value to update the LEC flush-timeout parameter.

Table 8-17 Task Actions

Menu Sequence	Enter	Result
[5] le	1 Bridge Number {0-3}	The LEC flush-timeout parameter is updated for the specified bridge.
[3] operational	2 LEC flush-timeout {1-4}	
[8] flush		

Example

Enter: [5][3][8] 0 3

The flush-timeout parameter for the LEC of bridge #0 is updated to 3 seconds.

Path-switching-delay

Enter the bridge number and path-switching-delay value to update the LEC path-switching-delay parameter.

Table 8-18 Task Actions

Menu Sequence	Enter	Result
[5] le	1 Bridge Number {0-3}	The LEC path-switching-delay parameter is updated for the specified bridge.
[3] operational	2 LEC path-switching-delay {1-8}	
[9] path switch		

Example

Enter: [5][3][9] 0 5

The path-switching-delay parameter for the LEC of bridge #0 is updated to 5 seconds.

Connection-completion-timer

Enter the bridge number and connection-completion-timer value to update the LEC connection-completion-timer parameter.

Table 8-19 Task Actions

Menu Sequence	Enter	Result
[5] le	1 Bridge Number {0-3}	The LEC connection-completion-timer parameter is updated for the specified bridge.
[3] operational	2 LEC connection-	
[10] completion	completion-timer {1-10}	

Example

Enter: [5][3][10] 0 7

The connection-completion-timer parameter for the LEC of bridge #0 is updated to 7 seconds.

Display LEC Control-frame Statistics

Displays the LEC control frame statistics for the specified bridge number (refer to Table 8-21). For more information see “Emulated LAN Connections” on page 12-7.

Table 8-20 Task Actions

Menu Sequence	Enter	Result
[5] le [4] lec-control	Bridge Number {0-3}	LEC control frame statistics for the specified bridge are displayed.

Table 8-21 LEC Control Frame Statistics

Parameter	Description
Arp (In Requests)	Number of LE_ARP requests received by the LEC. LE_ARP requests are sent to determine the ATM address associated with a given MAC address.
Narp (In Requests)	Number of negative LE_ARP requests received by the LEC. Negative LE_ARP requests are sent by an LE client to advertise changes in remote address bindings.
Topology (In Requests)	Number of topology change requests received by the LEC.
Flush (In Requests)	Number of flush requests received by the LEC.
Config (In Responses)	Number of configuration responses received by the LEC.
Join (In Responses)	Number of join responses received by the LEC.
Register (In Responses)	Number of register responses received by the LEC.
Unregister (In Responses)	Number of unregister responses received by the LEC.
Arp (In Responses)	Number of LE_ARP responses received by the LEC.
Arp Eavesdrop (In Responses)	Number of LE_ARP responses that were not meant for the LEC that were received and learned from.
Ready Query (In Ready Frames)	Number of READY_QUERY messages received by the LEC.
Ready Ind (In Ready Frames)	Number of READY_IND messages received by the LEC.
Msg Error (In Errors)	Number of errored LE control frames received by the LEC.
Wrong Type (In Errors)	Number of LE control frames of the wrong type received by the LEC.

Table 8-21 LEC Control Frame Statistics (continued)

Parameter	Description
Not Ours (In Errors)	Number of LE control frames not intended for the LEC received.
Not Learn (In Errors)	Number of LE control frames which were discarded because the LEC was not in an appropriate state.
Config (Out Requests)	Number of configuration requests sent by the LEC.
Join (Out Requests)	Number of join requests sent by the LEC.
Register (Out Requests)	Number of register requests sent by the LEC.
Unregister (Out Requests)	Number of unregister requests sent by the LEC.
Arp (Out Requests)	Number of LE_ARP requests sent by the LEC.
Narp (Out Requests)	Number of negative LE_ARP requests sent by the LEC.
Topology (Out Requests)	Number of topology change requests sent by the LEC.
Flush (Out Requests)	Number of flush requests sent by the LEC.
Arp (Out Responses)	Number of LE_ARP responses sent by the LEC.
Flush (Out Responses)	Number of flush responses sent by the LEC.
Ready Query (Out Ready Frames)	Number of READY_QUERY messages sent by the LEC.
Ready Ind (Out Ready Frames)	Number of READY_IND messages sent by the LEC.
Bad Status (Out Errors)	Number of bad status LE control frame responses sent by the LEC.
Bad State (Out Errors)	Number of frames not sent by the LEC because it was not in the appropriate state to send them.
Gen Error (Out Errors)	Number of LE control frames not sent due to internal errors.

Example

Enter: [5][4] 0

The LEC control frame statistics for the bridge #0 are displayed as follows:

```
-----
Statistics for LE Client of bridge 0:
=====
```

```
In Requests:
-----
```

```
Arp      :      25          Narp      :      0
Topology :      0          Flush     :      9
```

```
In Responses:
-----
```

```
Config   :      0          Join     :      1
Register :      0          Unregister :      0
Arp      :      24          Arp Eavesdrop :      3
Flush    :      14
```

```
In Ready frames:
-----
```

```
Ready Query :      0          Ready Ind :      1
```

```
In Errors:
-----
```

```
Msg Error :      0          Wrong Type :      0
Not Ours  :      34          Not Learn  :      1
```

```
Out Requests:
-----
```

```
Config   :      0          Join     :      1
Register :      0          Unregister :      0
Arp      :      37          Narp     :      0
Topology :      0          Flush    :      14
```

```
Out Responses:
-----
```

```
Arp      :      25          Flush    :      9
```

```
Out Ready frames:
-----
```

```
Ready Query :      0          Ready Ind :      2
```

```
Out Errors:
-----
```

```
Bad Status :      0          Bad State :      0
Gen Error  :      1
```

Figure 8-4 LEC Control Frame Statistics Display.

Reset LEC Control-frame Statistics

Resets the LEC control-frame statistics to zero for the specified bridge. For more information see “Emulated LAN Connections” on page 12-7.

Table 8-22 Task Actions

Menu Sequence	Enter	Result
[5] le [5] reset	Bridge Number {0-3}	LEC control frame statistics are reset to zero for the selected bridge.

Example

Enter: [5][5] 0

The LEC control frame statistics are reset to zero for bridge #0.

Update Unknown Unicast-flood-Mode

Updates the unknown unicast-flood-mode for the specified bridge. The change takes place at the next reset. For more information see “Unknown Unicast Frames” on page 12-15.

Table 8-23 Task Actions

Menu Sequence	Enter	Result
[5] le [6] flood	<ol style="list-style-type: none"> 1 Bridge Number {0-3} 2 Unicast flood mode: <ul style="list-style-type: none"> ■ N<ot Flood> ■ Req <Arp> ■ Res <pArp> 	<ul style="list-style-type: none"> ■ N<ot Flood> - No unicast frames are sent to the BUS for the specified bridge ■ Req <Arp> - Unicast frames are sent to the BUS for the specified bridge, until the LE_ARP request is sent ■ Res <pArp> - Unicast frames are sent to the BUS for the specified bridge, until the LE_ARP response is received

Example

Enter: [5][6] 0 N

No unicast frames are sent to the BUS for the specified bridge and the following message is displayed.

```
The LE flood mode for Bridge #0 is now: NotFlood
```

9

SETTING NETWORK PARAMETERS

This chapter contains detailed descriptions of common management tasks for setting up your 7600 Card to work with an SNMP manager (for example, Transcend ATM Manager), TFTP or Telnet (if working through the CELLplex 7000 unit). An IP address, subnet mask and Default Gateway must be defined in the bridge to which the SNMP manager is connected.

The IP address is used to identify the 7600 Card within the network. The SNMP and TFTP use this address when connecting to the 7600 Card.

The Network Management Station (NMS) IP address is defined in the 7600 Card to enable the unit to send SNMP traps to the NMS.

The following management tasks are covered:

Manage IP parameters

- Display Current IP Configuration
- Update IP Address
- Update Default Gateway
- Update Subnet Mask

Manage SNMP parameters

- Display SNMP Configuration
- Update NMS IP Address

Display Current IP Configuration

Displays the current IP configuration for each of the bridges (refer to Table 9-2).

Table 9-1 Task Actions

Menu Sequence	Enter	Result
[7] management [1] ip [1]display	None	Current IP configuration parameters are displayed for all bridges

Table 9-2 IP Configuration Information

Parameter	Description
Bridge	The number of the bridge (virtual network).
IP addr	The IP address of the bridge.
Subnet Mask	The IP address bit mask of the subnet where the specified bridge is located. Applying the subnet mask on the IP address (depending on its class - A, B or C) determines the IP address; subnet address.
Def. Gateway	The IP address of the default gateway (router) connected to the specified bridge. The default gateway is only required if routers are being used in the network. There can be only one router defined per virtual network (Bridge).

Example

Enter: [7] [1] [1]

The following is displayed:

```

-----
Bridge: 0   IP addr.      : 100.0.0.1   Subnet Mask: 255.255.255.0
           Def. Gateway: 100.0.0.55
Bridge: 1   IP addr.      : 100.0.2.2   Subnet Mask: 255.255.255.0
           Def. Gateway: 100.0.2.99
-----
    
```

Figure 9-1 IP Configuration Display.

Update IP Address

Enter the bridge number and the new IP Address to update the IP Address for the specified bridge.

Table 9-3 Task Actions

Menu Sequence	Enter	Result
[7] management	1 Bridge Number {0-3}	IP Address is updated for specified bridge.
[1] ip	2 IP Address	
[4] ip-addr		

Example

Enter: [7] [1] [4] 0 100.0.2.2

The IP Address for bridge #0 is updated to 100.0.2.2

Update Default Gateway

Enter the bridge number and the new Default Gateway to update the Default Gateway for the specified bridge.

Table 9-4 Task Actions

Menu Sequence	Enter	Result
[7] management	1 Bridge Number {0-3}	Default Gateway is updated for specified bridge.
[1] ip	2 Default Gateway	
[5] gateway		

Example

Enter: [7] [1] [5] 0 100.0.2.88

The Default Gateway for bridge #0 is updated to 100.0.2.88

Update Subnet Mask

Enter the bridge number and the new subnet mask to update the subnet mask for the specified bridge.

Example

Table 9-5 Task Actions

Menu Sequence	Enter	Result
[7] management	1 Bridge Number {0-3}	Subnet Mask is updated for specified bridge.
[1] ip	2 Subnet Mask	
[6] mask		

Enter: [7] [1] [6] 0 255.255.255.0

The Subnet Mask for bridge #0 is updated to 255.255.255.0

Display SNMP Configuration

Displays the SNMP configuration.

Table 9-6 Task Actions

Menu Sequence	Enter	Result
[7] management	None	The SNMP configuration is displayed.
[2] snmp		
[1] display		

Table 9-7 SNMP Configuration Information

Parameter	Description
Bridge	The number of the bridge (virtual network).
Default NMS	The IP address for the default Network Management Station (NMS) for the specified bridge.

Example

Enter: [7] [2] [1]

The SNMP configuration is displayed as follows:

```

-----
Bridge:  0      Default NMS: 100.0.0.92
Bridge:  1      Default NMS: 100.0.2.93
-----

```

Figure 9-2 SNMP Configuration Display.

Update NMS IP Address

Enter the bridge number and the new NMS IP address to update the Network Management Station (NMS) IP address, for receiving SNMP traps.

Table 9-8 Task Actions

Menu Sequence	Enter	Result
[7] management	1 Bridge Number {0-3}	IP address is updated for specified bridge.
[2] snmp	2 IP address	
[2] nms-addr		

Example

Enter: [7] [2] [2] 0 100.0.0.92

The IP address for bridge #0 is updated to 100.0.0.92

10

MANAGING SYSTEM FUNCTIONS

This chapter contains detailed descriptions of common management tasks for the system functions of the 7600 Card.

The following system functions tasks are covered:

Manage software and hardware configuration

- Display Software Version
- Display Software Download Status
- Download Software from Network
- Erase Software from Flash
- Download Software from Local
- Display Hardware Configuration

Update the system working mode and attributes

- Set System Configuration Mode
- Set Store-and- Forward Mode

.Manage timeout parameters

- Display Timeout Parameters
- Display Timeout Delays
- Update Hardware Timeout Delay
- Update Software Timeout Delay

Manage flash memory

- Reset Flash Memory

Update console passwords

- Update Read-access Password

- Update Write-access Password
- Update Admin-access Password

Manage event messages

- Enable/Disable Event Messages

Resetting system

- Reset and Reboot

Display Software Version

Displays the current software version, revision number and date of implementation.

Table 10-1 Task Actions

Menu Sequence	Enter	Result
[1] system [1]display	None	The current software version, revision number and date of implementation are displayed

Example

Enter: [1] [1]

The current software version, revision number and date of implementation are displayed as follows:

 Software version Ver. 3.17 - Built Oct. 22 1996 17:39:57

Display Software Download Status

Display the status of the last TFTP software download.

Table 10-2 Task Actions

Menu Sequence	Enter	Result
[1] system [9] load [1] display	None	Status of last TFTP software download is displayed.

Example

Enter: [1] [9] [1]

Status of last TFTP software download is displayed:

Download Software from Network

Download the software via the network by TFTP.

Table 10-3 Task Actions

Menu Sequence	Enter	Result
[1] system [9] load [2] tftp	1 Server IP address 2 File to be downloaded	System software is downloaded via tftp.

Example

Enter: [1] [9] [2] 100.0.0.24 applic.swf

System software is downloaded via tftp.

Erase Software from Flash

Erase the software program from flash prior to downloading of the new system software from a PC or workstation with a VT100 terminal emulation attached directly to the 7600 Card through the emergency serial port.



The software may be loaded without this step.

Table 10-4 Task Actions

Menu Sequence	Enter	Result
[1] system [9] load [3] local	None	System software is erased from flash.

Example

Enter: [1] [9] [3]

System software is erased from flash.

Download Software from Local

To load a new version of the system software locally, use the following procedure:

- 1 Run the terminal emulation program, for example, PROCOMM Plus.
- 2 Pull out the Switch Board from the CELLplex 7000 Switch and leave it out until the procedure is finished.
- 3 Connect the terminal to the internal RS-232 connector located on the right side of the rear-mounted daughter board.
- 4 Reset the unit.
- 5 Press Shift-U. The screen should read "Monitor port = LMA".
- 6 Change Baud Rate to 57600.
- 7 Press Enter and the prompt (>) appears.
- 8 Type "do" and use the terminal emulation software in binary mode to load the 7600 Fast Ethernet Card software. The name of the 7600 file is 763171.str.

- 9 The file will now download. When the download is complete, a prompt appears. Refer to the documentation of your terminal emulation for more information on downloading files.
- 10 Push the Switch Board back into the CELLplex 7000 Switch.
- 11 Restore Baud Rate to 19200.
- 12 Reset the unit.

Display Hardware Configuration

Hardware configuration information including a hardware diagnostic report, is displayed, showing the pass/failed status of each hardware element within the 7600 Card.

Table 10-5 Task Actions

Menu Sequence	Enter	Result
[1] system [2] status	None	The hardware configuration and pass/failed status of each hardware element within the 7600 Card is displayed.

Example

Enter: [1] [2]

The following is a sample hardware status report for one context:

```

-----
Context No. 1 Configuration

***      Utopia - Slave, TRAM - 256 K, CRAM - 512 K
***      ZipChip : type ZC2+
***      Hermon  : ver 3.3
***      TM      : ver 1.10
*** FE Port #1 : Installed
*** FE Port #2 : Installed
*** FE Port #3 : Installed
*** FE Port #4 : Installed

*** Context #4 diagnostics report:
*** -----
*** TRAM      : 256 K pass
*** CRAM      : 1024 K pass
*** SRAM      : 32 K pass
*** FRAM      : 128 K pass
*** ZipChip Diagnostic      : pass
*** TM Register Diagnostics : pass
*** ZipChip Diagnostic      : pass
*** SEEC Diagnostics       : pass
*** Check cells chaining   : pass
*** Interrupts diagnostics  : pass
*** HW Diagnostics         : pass
-----

```

Figure 10-1 Hardware Configuration Display

Set System Configuration Mode

Enter the desired system configuration mode. The default mode is the current system configuration mode.

Table 10-6 Task Actions

Menu Sequence	Enter	Result
[1] system [3] update [5] mode	■ L<E> (LAN Emulation)	■ LAN Emulation - standard LAN Emulation The mode is saved in flash.

Example

Enter: [1] [3] [5]

The system configuration mode is set according to following prompt. The current mode is displayed after the colon. To accept it press "enter"; to change it type over the new choice and press "enter".

```
Select system mode (L<E>): L
```

Set Store-and-Forward Mode

Set the desired store-and-forward mode. The mode is saved in flash. The mode set applies to all frames arriving from all Ethernet ports and all frames arriving from the ATM ports. This mode change takes effect only after the next reset.

Table 10-7 Task Actions

Menu Sequence	Enter	Result
[1] system [3] update [6] s&f	Enter <i>S<&f> or C<utthru></i>	<ul style="list-style-type: none"> ■ Store & forward - the entire frame is received before being forwarded to its destination. ■ Cut-through - the cells of the frame are forwarded to their destination before the entire frame is received

Example

```
Enter: [1] [3] [6]
```

The store-and-forward mode is set according to following prompt. The current mode is displayed after the colon. To accept it press "enter"; to change it type over the new choice and press "enter".

```
Select mode (S<&F>, C<utThru>): C
```

Display Timeout Parameters

Display the software and hardware timeout parameters. Refer to Table 10-9 for descriptions of the timeout parameters.

Table 10-8 Task Actions

Menu Sequence	Enter	Result
[1] system [3] update [8] timeout [1] info	None	The software and hardware timeout delays are displayed.

Table 10-9 Timeout Parameters

Name	Description
Timeout Delay	The software and hardware timeout delay in seconds
Current Time	The current time being used by the 7600 Card
Timeout Interrupts	The number of interrupts registered by the timeout mechanism
False Interrupts	The number of false interrupts detected by the software.
Events Captured	The number of interrupts the hardware reported timeouts for.
Events Confirmed	The number of software confirmed Ethernet segment timeouts.
Server Released	The number of times the server released frames automatically without intervention by the hardware or software.
MACE Stucked	The number of times timeouts were caused due to a heavy load on the physical line.
Queue invalid	The number of times the frame came in on an invalid VC.
Wait for end SW TO	The number of timeouts that occurred in the software.
Wait for end HW TO	The number of timeouts that occurred in the hardware.
Events processed	The number of hardware timeouts processed that the software caused to discard the frame abnormally.
SW TO processed	The number of software timeouts processed that the software caused to discard the frame abnormally.
TO from ETH	The number of frames from the Ethernet that caused timeouts.
Server events	The number of events by Ethernet segment.

Table 10-9 Timeout Parameters (continued)

Name	Description
Empty cell counter	The number of free cells in CRAM.
Full queues mask	The current status of the queues (12 Ethernet, 1 ATM, and the software queue). When the bit is set, the queue is full.
Disable SW bdcats	The number of times the software closed broadcasts from going to it, due to a heavy load.
Enable SW bdcats	The number of times the software opened to enable broadcasts to go to it.
Spare Cell Busy	The number of times the previous timeout was not completed.
Spare Cell Busy (SW)	The number of times the previous software timeout was not completed.
Number of items in output queues	Lists each queue (12 Ethernet, 1 ATM and 1 to the software) and the number of items in waiting in each queue.

Example

Enter: [1] [3] [8] [1]

The following is a sample timeout parameters report:

```

-----
Timeout recovery process report:
-----
Timeout delay      : 30 (SW: 30)
Current time      : 31494918
Timeout interrupts : 64
False interrupts  : 0
Events captured   : 0
Events confirmed  : 0
Server released   : 64
MACE stucked     : 0
Queue invalid     : 0
Wait for end SW TO : 0
Wait for end HW TO : 0
False alarms_1   : 0
False alarms_2   : 0
Events processed  : 0
SW TO processed   : 0
TO from ETH      : 0
Server events    : 0, 64, 0, 0, 0, 0, 0, 0, 0, 0, 0
Empty cell counter : 3fel
Full queues mask  : 0000
Disable SW bdcats : 0000
Enable SW bdcats  : 0000
Single cell CPI > 1 : 0000
Problems         : 0
Frames CPI=0     : 0
Frames CPI=0(SW) : 0
Invalid CPI      : 0
Invalid CPI(SW) : 0
Invalid hptr     : 0
Invalid index    : 0
Spare Cell Busy  : 0
Spare Cell Busy(SW) : 0
Spare Cell Fail  : 0
Spare Cell Fail(SW) : 0

Number of items in output queues:
I=====I=====I=====I=====I=====I=====I=====I
I 1 I 2 I 3 I 4 I 5 I 6 I 7 I
I 0 I 0 I 0 I 0 I 0 I 0 I 0 I
I=====I=====I=====I=====I=====I=====I=====I
I 8 I 9 I 10 I 11 I 12 I ATM I SW I
I 0 I 0 I 0 I 0 I 0 I 0 I 0 I
I=====I=====I=====I=====I=====I=====I=====I

```

Figure 10-2 Timeout Parameters Display

Display Timeout Delays

Display the software and hardware timeout delays.

Table 10-10 Task Actions

Menu Sequence	Enter	Result
[1] system	None	The software and hardware timeout delays are displayed.
[3] update		
[8] timeout		
[2] display		

Example

Enter: [1] [3] [8] [2]

The following is a sample timeout delays report:

```
-----
Hardware Timeout delay: 30.
Software Timeout delay: 30.
-----
```

Update Hardware Timeout Delay

Enter the new hardware timeout delay (in seconds) or 0 to disable the hardware timeout mechanism.

Table 10-11 Task Actions

Menu Sequence	Enter	Result
[1] system	Time-delay	■ Time-delay - Hardware time-delay parameter is updated
[3] update	or 0	
[8] timeout		■ 0: Hardware timeout mechanism is disabled
[3] hardware		

Example

Enter: [1] [3] [8] [3] 10

The hardware time-delay parameter is updated to 10 seconds; the following message is displayed:

Hardware Timeout delay has been set.

Update Software Timeout Delay

Enter the new software timeout delay (in seconds) or 0 to disable the software timeout mechanism.

Table 10-12 Task Actions

Menu Sequence	Enter	Result
[1] system [3] update [8] timeout [4] software	Time-delay or 0	<ul style="list-style-type: none"> ■ Time-delay - Software time-delay parameter is updated ■ 0: Software timeout mechanism is disabled

Example

Enter: [1] [3] [8] [4] 10

The software time-delay parameter is updated to 10 seconds; the following message is displayed:

Software Timeout delay has been set.

Reset Flash Memory

Resets the flash memory with the default factory settings for the 7600 Card, resets and reboots the device.

Table 10-13 Task Actions

Menu Sequence	Enter	Result
[1] system [5] flash	None	The flash memory is reset with the default factory settings and the device is reset and rebooted.

Example

Enter: [1] [5]

The flash memory is reset with the default factory settings and the device is reset and rebooted

Update Read-access Password

Update the read-access password. Type the new password a second time to confirm your entry.

Table 10-14 Task Actions

Menu Sequence	Enter	Result
[1] system	1 password	The read-access password is updated.
[6] password	2 confirmation	
[1] read		

Example

Enter: [1] [6] [1]

The following dialog is displayed. Note that the passwords themselves are not displayed.

```
Enter the new read password: myreadpassw
Enter the new read password again: myreadpassw
The password has been changed
```

The read-access password is updated.

Update Write-access Password

Update the write-access password. Type the new password a second time to confirm your entry.

Table 10-15 Task Actions

Menu Sequence	Enter	Result
[1] system	1 password	The write-access password is updated.
[6] password	2 confirmation	
[2] write		

Example

Enter: [1] [6] [2]

The following dialog is displayed. Note that the passwords themselves are not displayed.

```
Enter the new write password: mywritepassw
Enter the new write password again: mywritepassw
The password has been changed
```

The write-access password is updated.

Update Admin-access Password

Update the admin-access password. Type the new password a second time to confirm your entry. You will be prompted for the existing password before you enter the new password.

Table 10-16 Task Actions

Menu Sequence	Enter	Result
[1] system	1 password	The admin-access password is updated.
[6] password	2 confirmation	
[3] admin		

Example

Enter: [1] [6] [3]

The following dialog is displayed. Note that the passwords themselves are not displayed.

```
Enter the old admin password: myadminpassw
Enter the new admin password: myadminpassw
Enter the new admin password again: myadminpassw
The password has been changed
```

The admin-access password is updated.

Enable/Disable Event Messages

Enable or disable Administration Console event messages. Each application of the command toggles enable/disable. If enabled, event messages pop-up on the Administration Console screen when events occur, for example, “link up” when a cable is connected to a port.

Table 10-17 Task Actions

Menu Sequence	Enter	Result
[1] system [7] event	None	Event messages are enabled/disabled.

Example

When Administration Console event messages are disabled Enter: [1]
[7]

Administration Console event messages are enabled.

Reset and Reboot

Reset system hardware and reboot the device for the new system settings to take effect.

Table 10-18 Task Actions

Menu Sequence	Enter	Result
[1] system [8] reset	None	System hardware is reset and device is rebooted.

Example

Enter: [1] [8]

This will reset and reboot the device? Are you sure (Y/N)?

System hardware is reset and device is rebooted.

III

7600 Card Capabilities

Chapter 11 Ethernet LANs and Bridges in the 7600 Card

Chapter 12 ATM, LAN Emulation, and Virtual LANs

Chapter 13 Traffic Management in the ATM Network

Chapter 14 Device Management

Chapter 15 System Modes, Attributes, and Tuning

11

ETHERNET LANs AND BRIDGES IN THE 7600 CARD

This chapter provides basic concepts and information about the following topics and how they are implemented in the 7600 Card.

- Overview of Ethernet
- Fast Ethernet
- Transparent Bridges
- Spanning Tree Protocol
- Bridged-LAN Environments and VLANs

Overview of Ethernet

An Ethernet is a CSMA/CD (Carrier Sense, Multiple Access with Collision Detection) LAN. *Carrier Sense* means that a device on an Ethernet senses the traffic and transmits only when the medium is idle. *Multiple Access* means that many devices share the same medium and have equal access rights to transmit. *Collision Detection* means that devices monitor the medium even while they are transmitting and so can detect a collision, that is, another station transmitting while they are transmitting.

The speed of transmission on an Ethernet LAN is normally 10 Mbps.

Stations on an Ethernet LAN can include computers, workstations or terminals. Ethernet LANs use a common bus that consists of a coax, twisted pair or fiber-optic cable that runs between the stations. The connection point of each station to the cable is called a *node*. Two or more LANs can be connected together by a bridge to form an efficient bridged-LAN environment. In this context, an Ethernet LAN is also called an Ethernet *segment*.

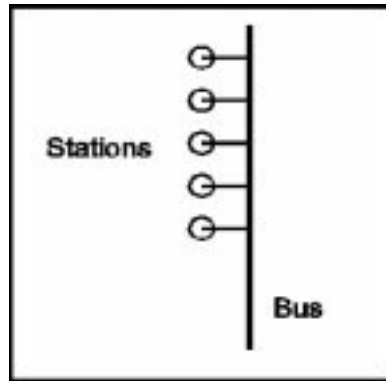

Figure 11-1 Ethernet LAN (Ethernet Segment)

Fast Ethernet

Fast Ethernet is a new LAN technology that uses the same CSMA/CD transmission method as the basic 10 Mbps Ethernet LAN described in the previous section but all timing parameters are increased by a factor of 10. In addition, it supports a full duplex mode as described below.

Fast Ethernet uses the same types of hub-and-spoke topologies used by 10BASE-T Ethernet, the dominant form of 10 Mbps networking in use today. It uses the same types of wiring, the same software protocols and is supported by a large number of the same vendors. In short, 100BASE-T provides a non-disruptive, smooth evolution from current 10BASE-T Ethernet to high-speed 100 Mbps performance.

The packet format, packet length, error control and management information in 100BASE-T are practically identical to those in Ethernet. To higher layers of software, 100BASE-T appears indistinguishable from regular Ethernet. All the popular protocols like TCP/IP, as well as applications, work on Fast Ethernet, only faster.

Network managers benefit substantially from the unchanged protocols; they can understand and deploy Fast Ethernet with minimal additional training.

Capabilities The Fast Ethernet ports of the 7600 Card have the following capabilities:

- Auto-negotiation
- Full/half duplex transmission mode

- 10/100 Mbps transmission speed

These capabilities differ between the Tx and Fx port types. They are presented in the following table and discussed in the paragraphs below.

Table 11-1 Fast Ethernet Port Capabilities

Capability	Port type	
	Tx Port	Fx Port
Auto-negotiation	yes	no
Full/half duplex	yes	yes
10/100 Mbps	yes	no (100 Mbps only)

Auto-negotiation

The 7600 Card has the capability of negotiating with the device with which it is to communicate prior to data transfer in order to determine its mode and speed capabilities (*auto-negotiation*). The 7600 Card then automatically adjusts its data transmission mode and speed to match that of the communicating device as detailed in the next two sections. Auto-negotiation is set for each port separately and may be set individually for either transmission mode or speed. If auto-negotiation is not specified, the parameter must be set manually. The auto-negotiation capability is available for Tx ports (copper) only.

Full or Half Duplex Mode

Fast Ethernet as implemented in the 7600 Card can communicate in either full or half duplex mode, for both Tx and Fx port types. The duplex auto-negotiation capability is available for Tx ports only. The Fx ports must be set manually to either full or half duplex. When duplex auto-negotiation is selected, the mode in which the 7600 Card chooses to operate is determined by the communication modes available in the device with which it is communicating. If the device with which it is communicating also has a full-duplex mode (such as another 7600 Card), then it communicates in full-duplex, otherwise it communicates in half-duplex.

10 or 100 Mbps Speed

The 7600 Card can communicate with either a 10 Mbps or in a 100 Mbps communication rate. This capability is available for the Tx port type only. The Fx ports communicate in 100 Mbps only. The Tx ports also have a speed auto-negotiation capability. When speed auto-negotiation is selected, the speed in which the 7600 Card chooses to operate is determined by the communication speed available in the device with which it is communicating. If the device with which it communicating also has a 100 Mbps speed (such as another 7600 Card) then it communicates in 100 Mbps, otherwise it communicates in 10 Mbps. The Fast Ethernet uses a lower *bit-time* (the time duration of each bit transmitted), but leaves the remainder of the Ethernet CSMA/CD unchanged.

Cabling Fast Ethernet supports structured wiring composed of category 3, 4, and 5 unshielded twisted pair (UTP), 150 ohm shielded twisted pair (STP) and fiber. These media specifications cover almost all cable types currently in use. Equally important, all supported media types can be mixed together and connected through a repeater or switch, just as with the earlier Ethernet media types.

To support these various wiring types, Fast Ethernet provides three transceiver types. A transceiver is that portion of an adapter containing the analog circuitry necessary to transmit and receive data on a physical cable. In Table 11-2, each transceiver type supports a different set of cable applications. It lists two twisted-pair-type transceivers and one fiber transceiver. These three Fast Ethernet transceiver technologies are complementary. The 7600 Card module uses the STP and fiber cable types.

Table 11-2 Cable Support by Transceiver Type

Transceiver type	Cable type	Number of pairs (fibers)	Notes
100BASE-T4	Category 3 UTP	4	Workhorse design for category 3 cable, 100-m link span
	Category 4 UTP	4	
	Category 5 UTP	5	
100BASE-TX	Category 5 UTP	2	Only needs two pairs, 100-m link span
	150 Ω STP	2	

Table 11-2 Cable Support by Transceiver Type

Transceiver type	Cable type	Number of pairs (fibers)	Notes
100BASE-FX	62.5/125 μm multi-mode fiber	2	Same optics as FDDI, 2-km link span

Fast Ethernet Ports

Ethernet LANs (*Ethernet segments*) are physically connected to the 7600 Card through one of its 16 Fast Ethernet ports. Each port has a unique address and port number. Figure 11-2 below shows Ethernet LANs connected to the 7600 Card Ethernet ports.

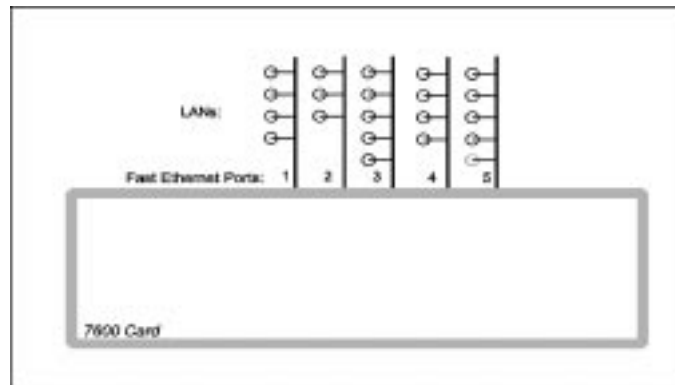
**Figure 11-2** Attaching Ethernet LANs to Ethernet ports on the 7600 Card

Disabling Ports

Individual Ethernet ports can be *enabled* or *disabled* by management and the corresponding *administrative status* can be displayed. When a port is disabled, data is not received or transmitted through the port.

Monitoring Ports

Each port is continuously monitored and the current *operational status* of the port (operating or not operating) can be displayed. Statistics on traffic through the port are compiled and can be displayed at any time. These include octets and frames (unicast, multicast, and broadcast) received and transmitted on the port, as well as discarded frames with the reason for discarding.

Transparent Bridges

The *transparent bridge* is a device that connects to two or more LANs and provides a selective data packet transfer capability between them which allows them to work in a bridged-LAN environment. The bridged-LAN can support more stations and a greater amount of traffic than can a simple LAN and, at the same time, it eliminates the cable length restriction between stations.

Bridge ports

A LAN is attached to a bridge through a *bridge port* which handles traffic between the LAN and the bridge. Each bridge port has a unique address. The bridge ports are numbered internally by the bridge. In the 7600 Card, bridge ports are numbered differently from the Ethernet ports to which the Ethernet LANs are physically attached. LANs are assigned to bridges by associating physical port numbers to bridge port numbers when setting up the device. Figure 11-4 below shows LANs connected to a bridge to form a bridged-LAN environment.

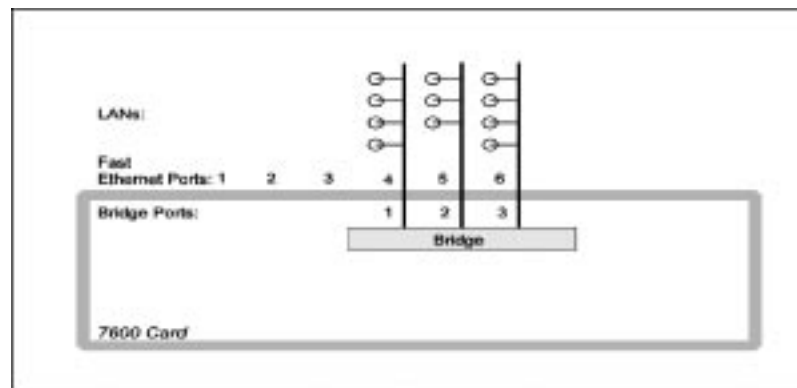

Figure 11-3 Forming a bridged-LAN environment

Store-and-Forward

The basic idea of the transparent bridge, as specified in the IEEE 802.1d bridging standard, is that it listens to every packet transmitted by the LANs to which it is attached, storing each received packet until it can be transmitted on the LANs other than the one on which it was received. Since the entire packet is stored in the bridge and retransmitted only when the receiving LANs are idle, the cable length restriction needed to avoid collisions in a single LAN can be exceeded between stations in the bridged LAN. In addition, the total number of stations in the bridged LAN can exceed the permissible number in a single LAN because each LAN is treated separately by the bridge.

Forwarding Database The effective bandwidth of the bridged LAN can be increased by means of the *Forwarding Database* (FDB), a memory cache in the bridge which contains a table of station addresses and associated bridge port numbers. The FDB provides the bridge port number of a received packet's destination station, allowing the bridge to transmit the packet directly to the correct LAN. The FDB is populated in three ways: by learning, by manual operator entry and by predefined data.

Learning Station Addresses The method of *learning* station addresses, specified in the IEEE 802.1d standard, is based on the presence of the transmitting station's (*source*) address in the transmitted packet. This makes it possible for the bridge to associate the source address with the bridge port on which the packet was received; the bridge now knows to which port the source station is connected. This information is stored in the FDB and remains there as long as the transmitting station is active. Because the learned addresses are not permanently written in the FDB, they are referred to as *dynamic* addresses.

Learning while forwarding The learning process is executed by the bridge at the same time that frame forwarding is occurring. The strategy goes as follows:

- 1 The bridge receives every packet transmitted by its attached LANs.
- 2 For each packet received, the bridge stores the address in the packet's source address field in the FDB together with the bridge port upon which the packet was received.
- 3 For each packet received, the bridge looks through its FDB for the packet's **destination address**.
 - a If the address is not found in the FDB, the bridge forwards the packet to all LANs except the one from which it was received (*flooding*).
 - b If the address is found in the FDB, the bridge forwards the packet only to the port specified in the table. If the specified port is the one from which the packet was received, the packet is dropped (*filtered*).
- 4 The bridge keeps track of each entry in the FDB and deletes it after a period of time (the *aging time*) in which no traffic is received with that address as the source address. This prevents overflowing of the FDB and also facilitates moving a station from one LAN to another. The bridge simply relearns its location. Aging time is one of the bridge parameters and can be specified by management.

Static Addresses The network manager may want to restrict a particular station to communicate only through specific input and output bridge ports in order to keep its traffic confined to certain portions of the network topology. Or, he may want to maintain a station that transmits so infrequently that it would be aged-out by the aging mechanism. For these cases the learning method is not suitable. Instead, the FDB provides for address entries called *static* addresses. These are entered or removed manually by the operator (and are therefore also called *Management* addresses) or they can be supplied with the device. The *Read-only* address is a special type of static address which is supplied with the device for internal use and cannot be altered. An example of a Read-only address is the address of a bridge port, called "*Self*".

Defining permanency of static addresses

In the 7600 Card, static addresses with various degrees of permanency can be defined as follows:

- Permanent - Entries that remain in the FDB when the device is reset
- Delete-on-Reset - Entries that are deleted when the device is reset
- Delete-on-Timeout - Static entry that is deleted after the aging time

Allowed ports for static addresses

Input and output bridge ports assigned (*allowed*) to a static address are entered or removed by the operator or are predefined. Static addresses can be addresses of individual destination stations but they are more frequently *multicast* addresses - addresses which include a group of destination stations. A packet with a multicast address normally needs to be transmitted on more than one bridge port in order to reach all the destination stations. Consequently, *multiple* output bridge ports are often allowed to a single static address. For data display, multiple allowed output ports are coded into a single binary number. Normally, one input (or *receiving*) port is allowed to a static address, but it is also possible to designate **all** ports as allowed receiving ports.

Blocking ports for static addresses

Instead of specifying the allowed input and output bridge ports for a static address, it is sometimes more convenient to specify those input and output bridge ports which are *not* allowed for that address (*blocked* ports). Then all ports other than the blocked ports can receive and transmit for that address.

Spanning Tree Protocol

When designing a bridged-LAN environment is it desirable to build redundant bridge links between LANs: in case one link fails, another can serve as a backup. However, when a LAN is attached to two or more

transparent bridges the bridged LAN can contain paths on which packets may loop and multiply, lowering its effective overall bandwidth.

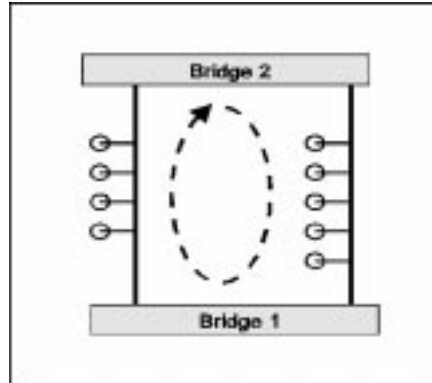

Figure 11-4 Packet looping through redundant bridges

To solve this problem, the IEEE 802.1d Bridging Standard describes the Spanning Tree Protocol (STP), an algorithm which seeks to establish a unique path between each pair of LANs in the bridged network by selectively blocking redundant bridge ports. The resulting loop-free tree *spans* the network: each LAN can access any other LAN. The STP continuously monitors the tree and, in the event of a failure, acts to establish a new spanning tree by reactivating blocked ports.

The STP is executed collectively by the bridges themselves by means of special messages called Configuration Bridge Protocol Data Units (CBPDUs) continuously sent between them. Using these messages, the bridges inform the other bridges of their unique *bridge-ID*, and they calculate the *shortest (lowest cost) path* from themselves to other locally-connected bridges. Using this information, the STP determines the following:

- Root Bridge* The *root-bridge* is selected among all bridges on the LANs as the one with the lowest bridge ID. The network manager can influence the algorithm's choice of root bridge through the management parameter *bridge-priority*. The bridge-priority is appended as the most significant part of a bridge ID; the lower its value, the more likely the bridge is to become the root.
- Root Port* Once the root bridge has been determined, each bridge selects the port with the shortest path from it to the root bridge to be the *root-port*.

Designated Bridge on a LAN Among all bridges on a LAN, the bridge with the shortest path to the root bridge (through its root port) is selected as the *designated-bridge* on that LAN.

Spanning Tree port selection Each bridge selects its root port and any of its ports (LANs) on which it is the designated bridge to be in the spanning tree. All other ports are blocked to data traffic (but not to CBPDUs). Thus, traffic on a LAN flows only through its designated bridge.

Re-configuring the Spanning Tree

When a change occurs in the network, such as a new bridge or link or a device failure, the STP acts to establish a new Spanning Tree configuration. Until the new Spanning Tree configuration stabilizes, it is necessary to restrict data packet transmissions in order to avoid temporary loops. For this purpose the 801.2 standard calls for two intermediate bridge port *states*: the *listening* state followed by the *learning* state. In the listening state is a wait state in which a port neither learns station addresses nor forwards data packets. In the learning state a port learns station addresses but still does not forward data packets. The management parameter *forward-delay* controls the amount of time that a bridge port remains in the listening or the learning state.

Port States Summing up, a bridge port can be in one of the following port states:

- **Listening** - When the Spanning Tree begins re-configuring after a network change, all ports are placed in the listening state. Data packets received on a port are discarded. After the forward-delay time, the bridge port enters the learning state, unless set to the blocking state by the STP.
- **Learning** - Data packets are received for the purpose of learning station addresses only. After the forward-delay time, the bridge port enters the forwarding state, unless set to the blocking state by the STP.
- **Blocking** - The bridge continues to send and receive CBPDUs on that port but does not receive data packets.
- **Forwarding** - The bridge performs standard bridging functions.

Disabling the STP

The STP can be disabled and enabled by management either for the entire bridge or for specific ports. When disabled, the port or bridge does not participate in the Spanning Tree algorithm but continues to receive and transmit data packets.

Management Bridge Parameters The following bridge parameters can be set by management. The parameters listed in Table 11-3, are port-independent while the parameters in Table 11-4 are set for individual bridge ports.

Table 11-3 Port-independent Bridge Parameters

Parameter	Description
Bridge-priority	A 2-octet value that allows the network manager to influence the choice of root bridge and the designated bridge. It is appended as the most significant portion of a bridge ID. It can also detect the case where two or more ports on the same bridge are attached to the same LAN, i.e. are in direct communication through a path of bridged LAN components, none of which operate the STP.
Bridge-hello-time	The time that elapses between generation of CBPDUs by a bridge that assumes itself to be the root bridge. It is also the time interval between transmissions of Topology Change Notification BPDUs to the root bridge when the bridge is trying to communicate a topology change to the designated bridge on the LAN to which its Root Port is attached. The recommended time is 2 secs.
Bridge-max-age	The message age value at which a stored CBPDU is discarded. The value recommended in 802.1d is 20 secs.
Bridge-forward-delay	A parameter that prevents a bridge from forwarding data packets until the changes in the spanning tree have been completed throughout the network. It is the time spent in the Listening State and the Learning State. It is also used for the aging time of dynamic entries in the Filtering Database while the Topology Change flag is set in protocol messages received from the root. The value recommended in 802.1d is 15 secs.
Bridge-aging-time	Dynamic station addresses are discarded from the FDB when no data is received from the station for bridge-aging-time. Static addresses with a delete-on-timeout status are also discarded after Bridge-aging-time. Recommended default: 5 min.

Table 11-4 Port-dependent bridge parameters

Parameter	Description
Bridge-port-priority	A 1-octet value that allows the network manager to influence the choice of port when a bridge has two ports connected in a loop. It is appended as the most significant portion of the port ID.
Bridge-path-cost	The cost to be added to the root path cost field to determine the cost of the path to the root through this port. The larger the value for the path-cost, the less through traffic the LAN reached through the port will carry.

Bridged-LAN Environments in the 7600 Card The 7600 Card provides a flexible, user-defined bridging capability designed to support local bridged-LAN environments of different sizes.

Local Bridged-LAN Environment

For the purpose of forming bridged-LAN environments, the 7600 Card provides up to 16 internal bridges that can be configured by management. On setup, one bridge is allocated to each bridged-LAN environment that is to operate in the 7600 Card. Each local LAN segment is then attached to a port of the bridge corresponding to the bridged-LAN environment in which it is to operate. Bridges are configured by management in the Fast Setup (see Chapter 3) or in the Virtual LAN Configuration menu see (Chapter 5). For management purposes the bridges are numbered from 0 to 3 in each one of the four contexts. Figure 11-5 shows two local bridged-LAN environments, Engineering and Finance, connected to bridges on a 7600 Card.

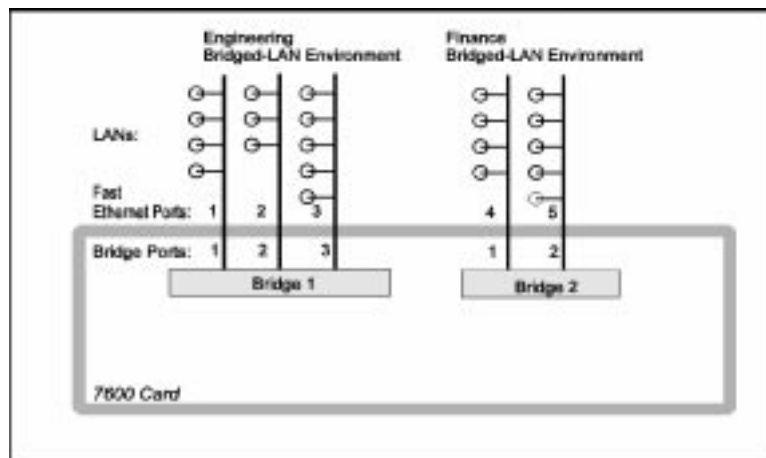

Figure 11-5 Bridged-LAN environments connected to a 7600 Card

Connection to the ATM Network

In Chapter 12, the possibility of connecting bridges in the 7600 to the ATM network is discussed. For each bridge, an ATM connection can be configured through which the bridge is attached to an Emulated LAN (see "Bridges in the 7600 Card" on page 12-10).

12

ATM, LAN EMULATION, AND VIRTUAL LANs

This chapter provides basic concepts and information about:

- ATM Overview
- Virtual Channels
- Interim Local Management Interface (ILMI)
- LAN Emulation Overview
- Emulated LAN Components
- Emulated LAN Connections
- Bridges in the 7600 Card
- Data Transmission over an Emulated LAN
- LEC Parameters
- Virtual LANs Overview
- Virtual LANs in the 7600 Card

ATM Overview

The *Asynchronous Transfer Mode* (ATM) is a telecommunications method for carriage of a complete range of user traffic, including voice, video and data. Defined by CCITT and ANSI standards, it facilitates multi-media networking between high-speed devices at multi-megabit speeds.

Using this connection-oriented, switched networking technology, virtual channels may be set up to support multiple applications through the same physical connection. The switching technology enables dedicated bandwidth for each application, overcoming the restrictions that exist in a shared-media networking technology, like Ethernet, Token Ring and FDDI. ATM allows different types of physical layer technology to share the same lower layer – the ATM layer.

ATM Basics

Cell Switching ATM uses short, fixed length packets called *cells*. The first five bytes of each cell, the header, contain the information necessary to deliver the cell to its destination.

Fixed-length cells offer the following advantages:

- Network and switching queueing delays are more predictable with fixed data cells than for variable-length packets.
- Cell switching is less complex and more reliable. ATM hardware can be implemented more efficiently because control structures, buffers, and buffer management schemes can be designed to known size criteria.
- Cell-relay switches can process cells in parallel, achieving speeds that far exceed the limitations of packet switch architectures.
- Having all data in the same cell format speeds transmission dramatically by eliminating the need for protocol recognition and decoding. A good analogy is containerised shipping where uniform shape and weight of containers and standardized labelling considerably ease and quicken processing.
- The cell format also allows for multi-protocol transmissions. Since ATM is protocol transparent, the various protocols can be transferred at the same time. With ATM, one line can carry phone, fax, video, data and other information simultaneously. This multiprotocol advantage also offers scalability, greatly reducing the configuration changes necessary for adding a new traffic type to your network.

Network interfaces ATM establishes the *User Network Interface* (UNI) which is typically used to interconnect an ATM user with an ATM switch that is managed as part of the same network, as well as the *Network to Network Interface* (NNI) which is typically used to interconnect two ATM switches managed as part of the same network.

Layered architecture ATM is based on a layered architecture. In the protocol stack, the ATM layer sits directly above the physical layer. Many *physical layers* can be specified, including several for 100 to 155 Mbps. The ATM adaptation layer (AAL) sits above the ATM layer. LAN Emulation (LE) sits above the AAL5 in the protocol hierarchy.

Virtual Channels

ATM is a connection-oriented transport service, much like a telephone. As opposed to Ethernet, where data is sent out on a common bus, ATM requires that a *virtual channel* connecting the source station to the destination station be established before data transmission can begin. A virtual channel does not necessarily correspond to a single physical line and, in fact, may pass through many different network devices and cables before reaching its destination.

Virtual Channel Connection

ATM seeks to establish an optimum path for a cell to travel through the ATM network from source to destination. This path is called a *virtual channel connection* (VCC). Its specification is coded into a *VCC identifier* which is then placed in each cell header. Using this information, high-speed buffer management and control schemes route ATM cells between ports along the path. To access the ATM network, a transmitting station requests a VCC between itself and a destination station, using the signalling protocol to the ATM switch. At connection time, a VCC is established between the stations and a VCC identifier is assigned to the connection.

Virtual Path Connection

In addition to the VCC, another type of virtual connection called a *virtual path connection* (VPC) can exist on the same physical link. The VPC is a higher level "container" connection which includes one or more VCCs.

A VCC is uniquely identified by the combination of *Virtual Path Identifier* (VPI) and *Virtual Channel Identifier* (VCI) values and a VPC is uniquely identified by the VPI value.

VPCs and VCCs can be set up either dynamically via signalling, in which case it is called a *switched virtual circuit* (SVC), or permanently by management where it is called a *permanent virtual circuit* (PVC).

Permanent Virtual Channels

A PVC connection is set up manually by management (for example, SNMP). A PVC connection, once established, is not automatically released and is not dynamically checked and reinitiated.

The characteristics of the PVC connection include:

- Connections initiated by network administrator
- Connections established and released manually
- Long-term duration connections

- Point-to-point and point-to-multipoint connections

Switched Virtual Channels

SVC connections are defined dynamically as they are needed and released when not needed, using signalling as per ATM Forum UNI standards. By using SVC, ATM devices can exchange connection characteristics when establishing connections. These connections remain active for as long as the application demands. Both point-to-point and point-to-multipoint connections can be established. SVC eliminates the need for an external management station for setting up virtual channels.

The characteristics of the SVC connection include:

- Connections initiated by the user/application
- Connections established and released dynamically
- Connections established via the signalling protocol
- Varied connection duration

Interim Local Management Interface (ILMI)

The *Interim Local Management Interface* (ILMI) communication protocol is an open management protocol that supports the bi-directional exchange of management information between all end-stations and the switches to which they are connected.

The ILMI functions for a UNI provide status, configuration, statistics, and control information about link and physical layer parameters at the UNI. In addition, it provides for address registration across the UNI. ILMI communications use SNMP directly over the AAL5.

For any ATM device, there is a connecting device associated with each UNI that supports the ILMI functions for that UNI.

ILMI Management Information Base (MIB)

Managed objects are accessed via a virtual information store, termed the Management Information Base or MIB. Each object defined in the MIB has a name, a syntax, and an encoding. The UNI ILMI attributes are organized in a standard MIB structure; there is one UNI ILMI MIB structure instance for each side of the UNI.

The IILMI MIB provides the management application with the capability to control and monitor the ATM link and physical layer. The following types of management information are available in the ILMI ATM UNI MIB:

- Physical Layer
- ATM Layer
- ATM Layer Statistics
- Virtual Path Connections (VPC)
- Virtual Channel Connections (VCC)
- Address Registration Information
- Service Registry Table

ATM Address Registration

In order to establish an ATM connection at the UNI, both the user and the network must know the ATM addresses which are in effect at that UNI. These ATM addresses can then be used in signaling messages for establishing connections with a specific ATM end system. The address registration procedure provides the means for the dynamic exchange of addressing information between the user and the network at the UNI, at initialization and at other times as required.

LAN Emulation Overview

LAN Emulation (LE) is a method of connecting LAN users over an ATM network which enables them to communicate with each other as if they were operating over traditional LANs. LE can be configured in a ATM network in several ways:

- To connect legacy end stations directly to other legacy systems, as well as to servers, routers, switches and other networking devices attached to the ATM network.
- To connect bridged-LAN environments to each other over ATM. In this case the Emulated LAN acts as a bridge on the ATM network.
- To connect ATM end stations to each other, enabling communication between them.

Emulated LAN Components

LAN Emulation is implemented as a set of connection services collectively called an *emulated LAN* (ELAN). Each ELAN is composed of a set of *LAN Emulation Clients* (LEC) and a single LAN Emulation Service. The latter consists of an *LE Configuration Server* (LECS), an *LE Server* (LES), and a *Broadcast and Unknown Server* (BUS). Each LE Client is incorporated in an ATM end station, such as a SuperStack II Switch 2700 or 7600 Card, and represents a set of LAN users, identified by their MAC addresses. The

LE Service normally resides on a central ATM switch, such as the CELLplex 7000, but may reside on an ATM end station instead.

An ELAN is assigned a name (*ELAN name*) which is communicated to each LEC as the LEC joins the ELAN.

More than one emulated LAN can operate on the same ATM network. However, each of the emulated LANs is independent of the others and users cannot communicate directly across emulated LAN boundaries.

LAN Emulation Client

The LEC is the LE connection service located in an ATM edge device which *represents* the device's LAN users to the ATM network. A LEC has a unique *LEC ID* as well as an *ATM address* by which it is known in the emulated LAN. It handles the forwarding of its LAN users' data frames over the ATM network to their destination, a task which also includes ascertaining the destination LEC address and setting up the connection between them.

Also provided is a MAC-level emulated Ethernet service interface to higher level software which implements the *LAN Emulation User to Network Interface* (LUNI).

LAN Emulation Server

The LES is the central "directory" service of an emulated LAN to which a LEC can turn to look up the ATM address of another LEC. The LES directory contains a table of LAN station MAC addresses together with the ATM addresses of the LECs that represent them. In order to transmit a data frame to a particular destination MAC address, the LEC sends the data frame to the LEC that represents that destination MAC address. If the LEC does not already know the destination LEC's address, it can send the destination MAC address to the LES to look it up (*resolve*). To populate the LES directory, the LECs may *register* the MAC addresses of LAN stations they represent with the LES.

Broadcast and Unknown Server (BUS)

The BUS is the LE connection service which handles ATM traffic other than direct transmissions between LECs. It handles the following:

- Data sent by a LEC to the broadcast MAC address
- All multicast traffic
- Initial unicast frames which are sent by a LEC before the data direct virtual connection to the ATM address has been resolved

- Unknown traffic

All broadcast, multicast and unknown traffic to and from a LEC passes through a single BUS.

The BUS also handles ATM connections and manages its distribution group.

LAN Emulation Configuration Server (LECS)

The LECS assigns individual LAN Emulation clients to different emulated LANs. When a LEC initializes, it establishes connection to the LECS. Based on its own programming, configuration database and information provided by clients, it assigns any client which requests configuration information to a particular emulated LAN service by giving the client the LES's ATM address. This method supports the ability to assign a client to an emulated LAN based on either the physical location (ATM address) or the identity of a LAN destination which it is representing (ELAN name).

Emulated LAN Connections

Emulated LAN components communicate with each other by means of VCCs. Control signals and data transmissions are handled by separate VCCs: Control VCCs and Data VCCs.

Control VCCs

The control VCCs carry control traffic such as LE_ARP requests and responses. On initialization, control VCCs are established between LEC and LES (bi-directional *control-direct* VCC and *control-distribute* VCC) as well as a bi-directional *configuration* VCC between LEC and LECS. Characteristics of the control VCCs are summarized in the following table.

Table 12-1 Control VCCs

VCC Name	From/To	Information carried	Initialized by	Duration
Configuration	LEC<==>LECS	LEC requests and receives configuration information from LECS, including LES address	LEC	While needed
Control-direct	LEC<==>LES	LEC sends and receives controls from LES, including LE_ARP information	LEC	Membership of LEC in ELAN
Control-distribute	LES==>LEC	LES distributes control traffic to LECs, including LE_ARP information	LES	Membership of LEC in ELAN

LEC Control Frame Statistics Display

The operator can display statistics on the various types of control frames in and out of the LEC (see “Display LEC Control-frame Statistics” on page 8-14)

Data VCCs

Data VCCs carry data frames between LECs and between a LEC and the BUS. Unicast data is normally sent from one LEC to another LEC by *data-direct* VCCs. Data direct VCCs are set up dynamically in a SVC environment by a transmitting LEC after ascertaining the ATM LEC destination address for the packet to be transmitted. Once established, a data-direct VCC remains in place for transmission of subsequent traffic between the two LECs. However, a data direct VCC that remains unused for *VCC-Timeout-period* is released by the LEC.

A multicast data VCC pair (*multicast-send* and *multicast-forward*) are established between a LEC and the BUS in order to allow the LEC to send and receive multicast data. In addition, *initial* unicast data (data whose LEC destination has not yet been ascertained by the transmitting LEC) is sent on the multicast-send VCC to the BUS which forwards it to all other LECs in the same ELAN. Characteristics of the data VCCs are summarized in the following table:

Table 12-2 Data VCCs

VCC Name	From/To	Information carried	Initialized by	Duration
Data-direct	LEC<==>LEC	Point-to-point Unicast data between LECs	LEC	Established by need and released when unused for VCC-Timeout-period.
Multicast-send	LEC<==>BUS	LEC sends multicast and initial unicast data to BUS	LEC	Membership of LEC in ELAN.
Multicast-forward	BUS==>LEC	BUS distributes data traffic to LECs	BUS	Membership of LEC in ELAN.

Figure 12-1 illustrates the VCCs active among LAN Emulation Components.

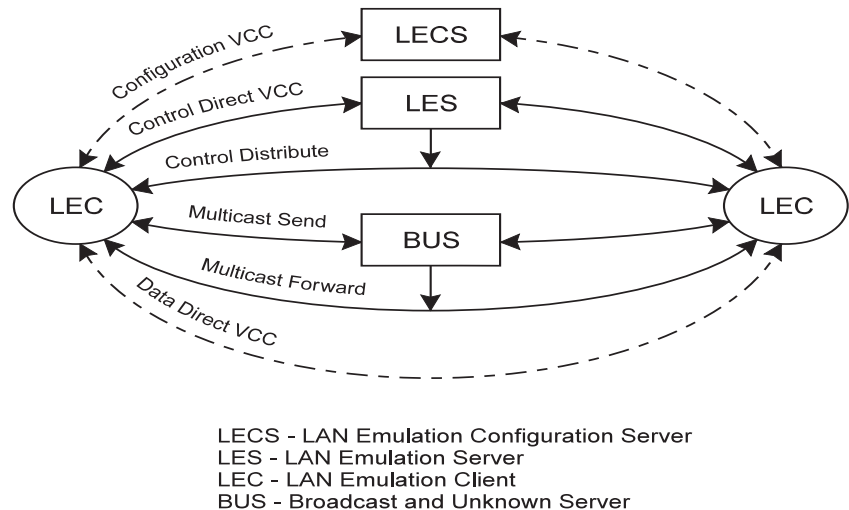

Figure 12-1 VCCs in LAN Emulation Components

LEC Configuration and Status Information

The following information about the configuration of the bridge LEC in the ELAN to which it belongs including connections to LECS, LES and BUS can be displayed to the operator (see "Display Current LEC Configuration" on page 8-4).

Table 12-3 LEC Configuration and Status Information

LECS Information	Description
ATM Address	The ATM address of the LECS. This address is obtained from the attached ATM Switch during initialization of the LEC. It is obtained via ILMI or, alternatively, retrieved from flash (manually assigned). If the address is not available by these methods, the <i>well-known</i> address is used to open a configuration VCC. The well-known address is displayed in this case.
Config VCC	VPI/VCI values of the configuration VCC to the LECS. It is an VCC which is determined during initialization of the LEC using the above LECS ATM address.
LES Information	Description
ELAN Name	The alphanumeric name of the Emulated LAN (ELAN) to which the LEC belongs. A default physical name is automatically provided when the LEC joins the ELAN. This physical name can be replaced with a descriptive name by management.
LEC ID	LAN Emulation Client (LEC) identification assigned by the LES.

Table 12-3 LEC Configuration and Status Information (continued)

ATM Address	ATM address of the LES provided by the LECS during the configuration phase or manually assigned using the LES address option of the LE configuration menu or in Fast Setup.
Control-direct VCC	VPI/VCI values of the control-direct VCC originated by the LEC to the LES.
Control-distribute VCC	VPI/VCI values of the control-distribute VCC originated by the LES to the LEC.
BUS Information	Description
ATM Address	ATM address of the BUS provided by the LES during initialization.
Multicast-send VCC	VPI/VCI values of the multicast-send VCC originated by the LEC to the BUS.
Multicast-forward VCC	VPI/VCI values of the multicast-forward VCC originated by the BUS to the LEC.

Bridges in the 7600 Card

In the 7600 Card a LEC is attached to each Ethernet transparent bridge which is set up in the device. The LEC connects the bridged-LAN environment attached to the transparent bridge to the ATM network and forwards LAN data frames over VCCs across the ATM network to the destination LANs. From the viewpoint of a LAN user, the LEC acts together with the transparent bridge to which it is attached to form a combined bridge through which the LAN user can now efficiently reach both local and remote destination LANs in the ATM network.

The physical connection of the transparent bridge to the ATM network is through an internal ATM port. The connection to the ATM port is specified when the bridge is set up. If no ATM connection is specified, the bridge acts like a standard transparent bridge.

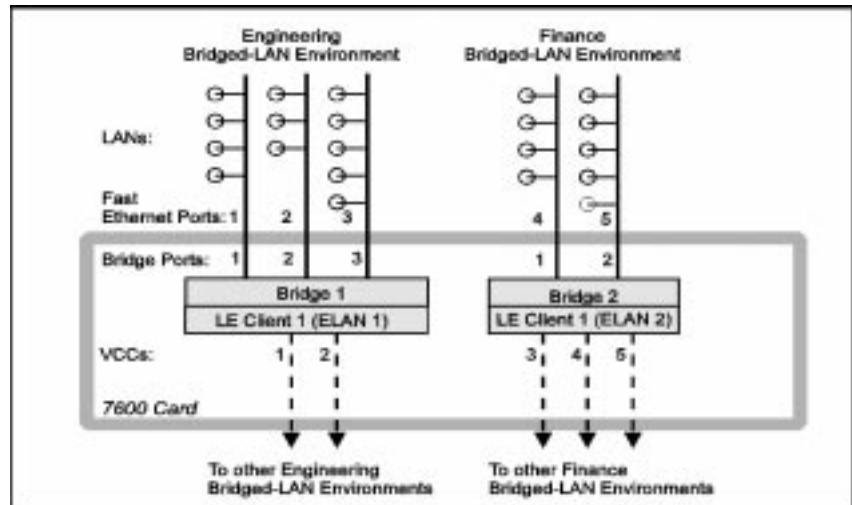

Figure 12-2 Bridges in the 7600 Card

The following figure shows data-direct VCCs configured between two 7600 cards:

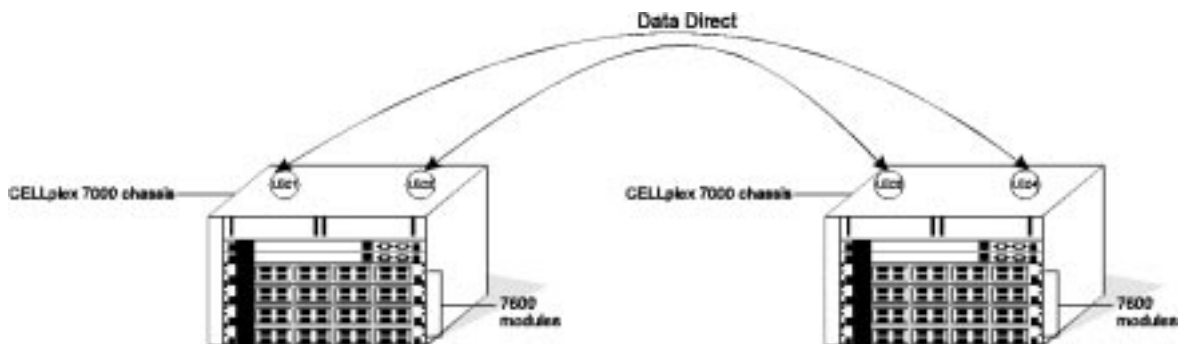

Figure 12-3 Virtual Circuit Connections

Cell Switching in the Bridge

In fact, both Ethernet and ATM switching in the bridge are combined in a single ASIC called *ZipChip*. Using a technique called *cell switching*, all data is converted to standard sized cells. The *ZipChip*'s local memory is optimized for storing these data cells. The data in the memory is either converted to Ethernet frames when transmitted on the Ethernet port or to ATM/LAN Emulation frames when transmitted on a VCC. The cell data need never be copied as it is merely converted to the appropriate format by the *ZipChip* on its way in and out of memory.

Bridge Forwarding Database

In order to forward data frames efficiently to both local LAN stations on the transparent bridge as well as to remote LAN stations represented by other LECs on the ATM network, a combined Forwarding Database (FDB) is established and maintained in the bridge. This FDB combines two tables. The first table is the FDB of the transparent bridge itself: a list of local LAN station MAC addresses together with the numbers of the bridge port to which they are attached (see “Forwarding Database” on page 11-7). The second table, called the *LE ARP-cache*, contains a list of remote LAN station MAC addresses together with the ATM addresses of the remote LECs which represent them. When a data frame is received at the bridge it searches its FDB for the destination MAC address. If the address is found to be local, the frame is forwarded to the appropriate bridge port. If the address is remote, the frame is sent over ATM to the destination LEC.

The part of the FDB of the bridge corresponding to the transparent bridge is populated as in a standard bridge (see “Forwarding Database” on page 11-7). The ARP-cache is populated by the following methods:

- Address resolution - querying the LES
- Address learning - from received data packets

Address Resolution

When the bridge needs to forward a unicast data frame whose destination MAC address is not found in its FDB it attempts to locate a LEC that represents the destination MAC address on the ATM network. To do this, it turns to the LES in a process called *address resolution*.

As mentioned above, the LES is the central “directory” service for verifying LEC ATM addresses on an ELAN (see “LAN Emulation Server” on page 12-6). The LEC submits an *LE_ARP* (LE Address Resolution Protocol) *Request* to the LES. If an LEC ATM address corresponding to the submitted MAC address is found in the LES table it is transmitted back to the requesting LEC as an *LE_ARP Response*. In case the requested address is not found at the LES, the LES will forward the query to other LECs to search the non-registered addresses and then return a positive response back to the requesting LEC. On receipt of an *LE_ARP Response* the bridge records the destination LEC ATM address together with the destination MAC address in its FDB ARP-cache.

Data-direct VCC On receipt of the destination LEC address, the transmitting LEC establishes a data-direct VCC for direct communication across the ATM network to the destination LEC if one does not already exist (the 7600 Card actually inserts a pointer to this VCC directly into the FDB so that a destination MAC address can be immediately associated with the right VCC).

VCC to BUS In a similar way, the bridge uses address resolution during initialization to ascertain the ATM address of the BUS. Once known, the multicast-send and multicast-forward VCCs are established between LEC and BUS and any unknown unicast, multicast or broadcast messages are sent on it.

Learning Addresses The bridge learns addresses from data frames received over data-direct VCCs in the same manner as the transparent bridge learns from data frames received from LAN stations on local Ethernet segments (see “Learning Station Addresses” on page 11-7). The bridge extracts the source MAC address in each received data frame and compares it with the entries in the FDB ARP-cache. If not found, it is inserted together with the ATM address of the LEC that sent it (or, equivalently, the pointer to the VCC on which it was received). Then, the next time a data frame needs to be sent to that MAC address, the bridge picks up its VCC from the FDB ARP-cache.

LES Address Registration in the 7600 Card To populate the LES directory, LECs are normally required to *register* the MAC addresses of LAN stations they represent with the LES. However, the situation is different for LAN stations which reside on a transparent bridge, as is the case for LANs attached to the 7600 Card. In this case, the LANs are considered to be “remote” from the LEC and the LEC is called a *proxy* for the bridged LANs. LES address registration does not apply to proxy LECs. Instead, LE_ARP requests for MAC addresses on bridged LANs are passed on by the LES to the proxy LEC for address resolution. The requested MAC address is found in the bridge FDB and returned in the LE_ARP response.

Unknown address Note that in the initial phase of operation of the ELAN, a MAC address of a bridged LAN station which has been requested from its proxy LEC may not have been learned yet by the bridge so that the LE_ARP request will be unsuccessful. As a result, a specific destination LEC address will not be available to the transmitting LEC and, consequently, no data-direct VCC will be established. A LAN station MAC address for which no destination LEC address is available yet is called an *unknown* address.

Aging in the LE_ARP Cache

As in the transparent bridge FDB, inactive entries in the LE_ARP cache are removed (aged out). Two LEC parameters are employed for this purpose: *aging-time* and *forward-delay-time*. The parameter used depends on the way the entry was originally obtained and if the *topology-flag* is set. When the topology flag is set "on" it means that the network is undergoing a change in configuration. The following table shows the conditions under which the appropriate aging parameter is chosen.

Table 12-4 Selecting Aging Parameters in the LE_ARP Cache

Entry obtained by	Topology flag	Aged by
Address resolution where address was registered in LES		Aging-time
Address resolution where address was not registered in LES, e.g. proxy LECs	■ Set	Forward-delay-time
	■ Clear	Aging-time
Address learned from received data frames	■ Set	Forward-delay-time
	■ Clear	Aging-time

Bridge Frame Forwarding Logic

A bridge processes an Ethernet frame received on a bridge port as follows:

- 1 The destination address is looked up in the combined Forwarding Database.
- 2 If the destination address is a local station MAC address the frame is forwarded directly to the bridge port corresponding to the address.
- 3 If the destination address is found on a remote LEC, the frame is converted to the standard LAN Emulation format and sent on to the ATM.
- 4 If the destination address is defined as "self", this signifies SNMP, CBPDU frames or any other traffic directed to the bridge software.
- 5 If the destination address is unknown, the frame is sent to all local bridge ports. In addition, it is sent to all other members of the ELAN according to the *unknown unicast flooding mode* (see "Unknown unicast flooding mode" on page 12-15).
- 6 Multicast addresses are handled similarly to unknown addresses; they are flooded.
- 7 Broadcast frames are sent to the bridge software as well as to all other ports on the bridge including the ATM.

Data Transmission over an ELAN

Unicast Frames When a LEC has established through address resolution that a certain LAN destination corresponds to a certain LEC ATM address, and a data-direct VCC exists to that ATM address, then a data frame addressed to that LAN destination is forwarded via that VCC.

Unknown Unicast Frames When a unicast frame to be transmitted by a LEC has an unknown address, a data-direct VCC is not yet available. In this situation, there are two possible actions that the LEC can perform, either separately or in combination:

- The unknown unicast frame can be transmitted over the multicast-send VCC to the BUS. The BUS forwards the frame to all LECs and their attached bridges then *flood* the frame to all bridge ports to ensure that the frame is received at its destination.
- Address resolution can be performed continuously on the unknown address until the address becomes known and a VCC can be set up.

Unknown unicast flooding mode

The 7600 Card allows these two actions to be performed in combination according to management selection. The *unknown unicast flooding mode* allows the user to specify one of the following possibilities for transmitting unknown unicast frames by a bridge:

Table 12-5 Unknown Unicast Flooding Mode

Mode	Bridge action
No flooding	No unicast frames are sent to the BUS.
Flooding until ARP Request	Unicast frames are sent to the BUS until the LE_ARP request is sent.
Flooding until ARP Response	Unicast frames are sent to the BUS until the LE_ARP response is received.

The number of unknown frames sent to the BUS in the time period *maximum-unknown-frame-time* is limited by the LEC parameter *maximum-unknown-frame-count*.

Flush protocol

According to the previous section, a unicast frame can be sent to a destination LEC over two VCC paths: a data-direct VCC or a multicast-send VCC via the BUS. Since a frame transmitted over a data-direct VCC may arrive sooner, switching between the two VCC paths during transmission can cause the frames to be received out-of-order at the destination LEC. The *flush protocol* is provided to ensure the correct order of delivery of unicast data frames at all times. The transmitting LEC establishes a dialog with the destination LEC to make sure that all traffic on the first VCC has been processed (flushed) before transmitting on the second VCC.

Multicast Frames

LECs may wish to send frames to a multicast MAC address, and/or they may wish to receive frames addressed to a given MAC address. In order to send frames to a multicast MAC address, the LEC sends the frames on the multicast-send VCC to the BUS. The LEC will also be able to receive flooded unicast frames and broadcast and multicast frames on the multicast-forward VCC from the BUS.

Control Information on Data VCs

In addition, the LE implementation of the 7600 Card complies with the standard and requires that control information be carried in-band on data VCs (Flush, Ready frames) and be identified by a special frame header (LECID field). The 7600 Card can extract these frames from the data as well as generate control frames as required.

LEC Statistics

Statistical information can be displayed about different types of data-frame traffic through the LEC (see "Display LEC Statistics" on page 8-2). The operator can also display statistics on the various types of control-frames in and out of the LEC (see "Display LEC Control-frame Statistics" on page 8-14)

LEC Parameters

The following LEC parameters govern the operation of the LEC; most can be set by management:

Table 12-6 LEC Operational Parameters

Parameter	Description	Minimum	Default	Maximum
Control-timeout	Time out period used for timing out most request/response control frame interactions.	10 seconds	120 seconds	300 seconds

Table 12-6 LEC Operational Parameters (continued)

Parameter	Description	Minimum	Default	Maximum
VCC-timeout	An LEC should release any Data-direct VCC that has not been used to transmit or receive any data frames for the length of the VCC timeout period. This parameter is only meaningful for SVC Data-direct VCCs.	None specified	20 minutes	Unlimited
Aging-time	The maximum time that an LEC will maintain an entry in its LE_ARP cache in the absence of a verification of that relationship	10 seconds	300 seconds	Unlimited
Forward-delay-time	The maximum time that an LEC will maintain an entry for a non-local MAC address in its LE_ARP cache in the absence of a verification of that relationship, as long as the Topology Change flag is true.	4 seconds	15 seconds	30 seconds
Expected LE_ARP Response-time	The maximum time that the LEC expects an LE_ARP request/response cycle to take. Used for retries and verifies.	1 second	1 second	30 seconds
Topology-change-flag	Boolean indication that the LEC is using the Forward delay time instead of Aging time to age non-local entries in its LE_ARP cache.	N/A	N/A	N/A
Flush-timeout	Time limit to wait to receive a LE_FLUSH response after the request has been sent, before taking recovery action.	1 second	4 seconds	4 seconds
Path-switching-delay	The time since sending a frame to the BUS after which the LEC may assume that the frame has been either discarded or delivered to the recipient. May be used to bypass the Flush protocol.	1 second	6 seconds	8 seconds
Connection-completion-timer	In Connection Establishment this is the time period in which data or a READY_IND message is expected from a Calling Party.	1 second	4 seconds	10 seconds
Maximum-unknown-frame-count	Maximum number of unknown frames sent to BUS during the time period Maximum-unknown-frame-time.	1 frame	1 frame	10 frames
Maximum-unknown-frame-time	Within the period of time defined by the Maximum-unknown-frame-time, a LEC will send no more than Maximum-unknown-frame-count frames to the BUS for a given unicast LAN destination.	1 second	1 second	60 seconds

Virtual LANs Overview

Virtual LANs (vLANs) represent location-independent logical user groups. LAN Emulation allows you to create enterprise-wide vLANs that closely correspond to how your network and business actually function. The

ability to define multiple emulated LANs permits the network manager to create several bridged LAN domains within a single ATM network.

vLANs create secure workgroups, erect firewalls against broadcast storms and allow networks to be reconfigured - all without changing cabling or adding equipment. Network administrators can implement additions, moves, and changes simply by redefining groups in the network management system and remotely configuring parameters in the end device or ATM switch.

In addition, vLANs can extend the life of routers in the network. Since traffic is switched within the vLAN at full rate, routers need only deal with the traffic between the vLANs, cutting down on the routed traffic load.

Since traffic is switched within vLANs at full rate regardless of protocol, you can configure the LAN in a variety of ways without inhibiting performance. This leaves your routers free to route traffic across the virtual LAN boundaries and into the WAN.

Virtual LANs in the 7600 Card

A vLAN brings together logically related, but not necessarily physically connected, Ethernet segments on the ATM network into a common high-bandwidth broadcast domain. A vLAN is defined simply as an Emulated LAN together with all segments attached to it and the stations connected to these segments. Multiple vLANs can operate independently on a single ATM network; each vLAN corresponds to a distinct ELAN.

Connecting Local Segments to a vLAN

A vLAN will usually contain some Ethernet segments physically connected to the 7600 Card (*local* segments) as well as *remote* segments located in different parts of the ATM network. Logically, the connection of the local Ethernet segments into a vLAN proceeds in two steps: first, they are formed into a local bridged-LAN environment by connecting them to a local bridge (see "Bridged-LAN Environments in the 7600 Card" on page 11-11) and then the local bridged-LAN environment is connected to remote bridged-LAN environments in the same vLAN by connecting the bridge to the Emulated LAN.

The 7600 Card bridge setup handles both of these steps. Local Ethernet segments are attached one-by-one to the appropriate bridge by simple menu actions. Then an ATM connection is requested, causing the bridge to be connected into an Emulated LAN. As a result, when the bridge setup is completed, the local bridged-LAN environment is already part of

a Virtual LAN. The LAN stations communicate over the VCCs set up by the ELAN.

Figure 12-4 shows how two such vLANs, for example Engineering and Finance, might be connected on the ATM network. Each vLAN has a separate ELAN (ELAN 1 and ELAN 2) which establish the data-direct VCCs on which members of the vLAN communicate. Figure 12-5 shows how an ELAN is embedded in a vLAN.

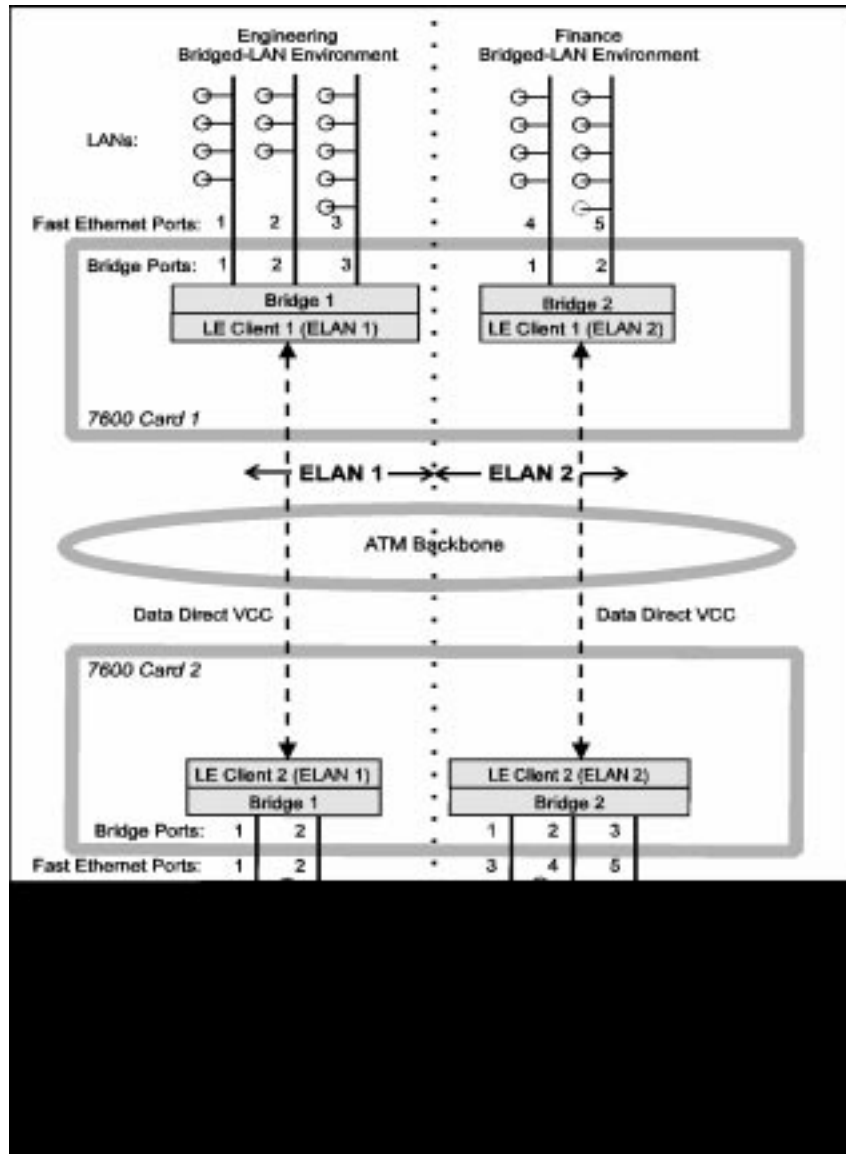

Figure 12-4 vLAN Connectivity through 7600 Cards

The following figure shows a different way of viewing the relation between ELAN and vLAN. The ELAN is embedded in the vLAN.

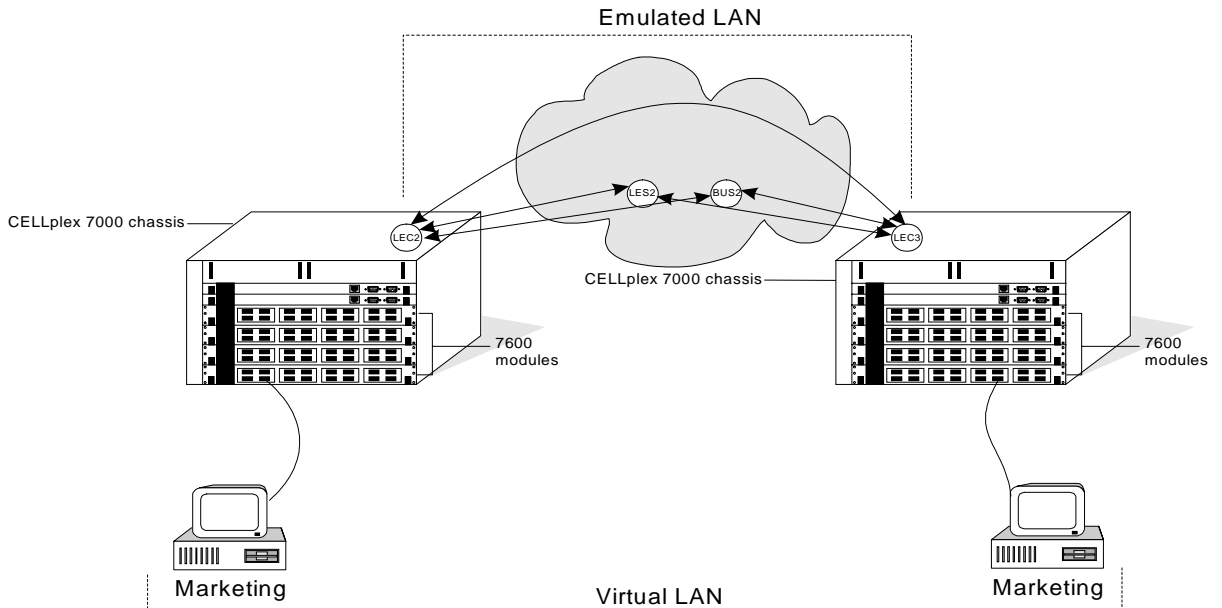

Figure 12-5 ELAN in a Virtual LAN

Virtual LANs for three Workgroups

Figure 12-6 shows the physical and virtual view of a network divided into three vLANs: Marketing, Finance, and Administration. Even though these workgroups are distributed over different floors, LAN Emulation allows them to be managed as if the users were in the same physical location. Each vLAN communicates with its server.

In the physical view of this network, the members of the Marketing and Finance groups are separated physically, though they are closely related in terms of the work that they do and how they use the network. The physical wiring does not reflect these logical relationships.

The virtual view shows how LAN Emulation can be used to create three virtual workgroups, each of them managed as if its members were linked locally. The LAN Emulation servers, which may reside in a switch or some other network device, help find the ATM addresses of desktop devices, regardless of where they are located.

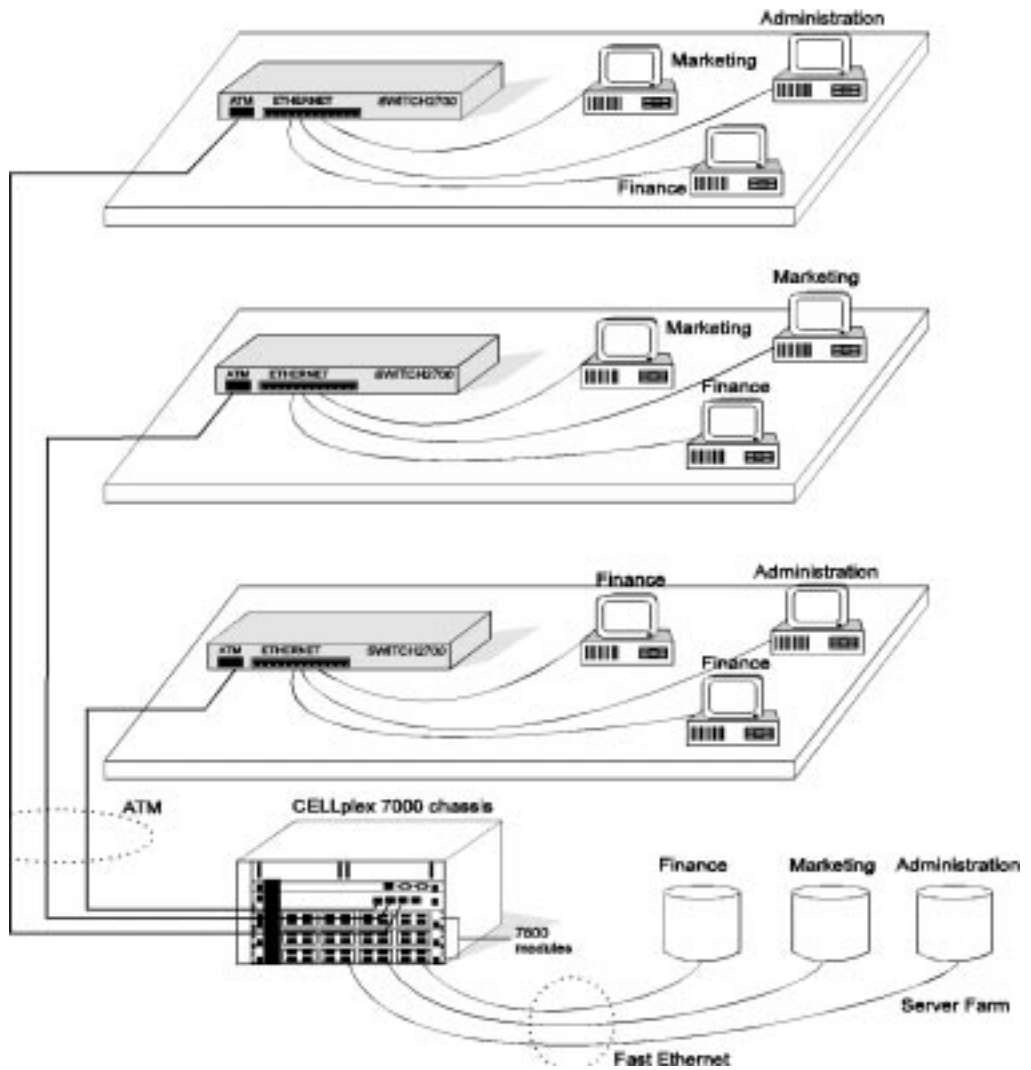

Figure 12-6 Logical and Physical View of a Network With vLANs

13

TRAFFIC MANAGEMENT IN THE ATM NETWORK

This chapter discusses the *Traffic Management* (TM) function within the ATM network and its implementation in the 7600 Card. The following topics are discussed:

- Overview of the concepts and operation of Traffic Management
- How Traffic Management is implemented within the 7600 Card

Overview

ATM technology is intended to support a wide variety of services and applications. Each type of application, whether it be voice, video or data, has its own special data transmission performance requirements. These requirements are expressed in a set of parameters called *Quality of Service* (QoS) which includes such factors as permissible transmission delay and loss of information. An important task of the ATM network is to be able to provide the appropriate QoS requirements for each application it is carrying. Traffic Management is provided on the ATM network to protect the network and the end-system from congestion in order to achieve network performance objectives. An additional role is to promote the efficient use of network resources. TM allows the devices to transmit over a broader bandwidth for longer periods of time, making the network more efficient.

Service categories

The 7600 Card's ATM data transmission Traffic Management is based on the *Available Bit Rate* (ABR) or *Unspecified Bit Rate* (UBR) "service categories". ABR allows a flow control mechanism to be established which supports data "feedback" to control the source data transmission rate in response to changing ATM layer congestion. This feedback is conveyed to the source through specific control cells called *Resource Management Cells*, or RM-cells. An end-system that adapts its traffic in accordance with the feedback will experience a low cell loss ratio and obtain a fair share of the available bandwidth according to a network specific allocation policy. No numeric commitment is made about cell

transfer delay. The ABR service does not require bounding the delay or the delay variation experienced by a given connection.

The UBR service category is inherently open-loop. UBR is not subject to a specific traffic contract but may be subject to a local policy in individual switches and end-systems. The UBR service category is intended for non-real-time applications, i.e. those not requiring tightly constrained delay and delay variation.

Flow Control Model for ABR

ABR flow control occurs between a sending end-system (source), such as a 7600, and a receiving end-system (destination). Sources and destinations are connected via bi-directional connections. For a bi-directional ABR connection, each connection termination point is both a source and a destination. For the sake of simplicity, only the information flow from the source to the destination with its associated RM-cell flows is considered. The forward direction is the direction from the source to the destination, and the backward direction is the direction from the destination to the source. Figure 13-1 shows the data flow and the RM-cell flow over a VCC connection between the two stations. Corresponding to the forward data flow from the source to the destination, there is a control loop consisting of two RM-cell flows, one in the forward direction and one in the backward direction.

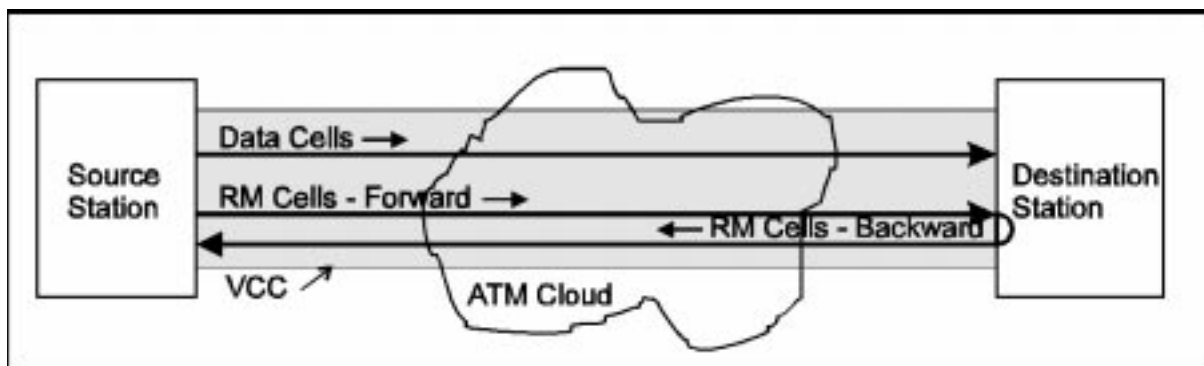

Figure 13-1 Example of a source to destination ABR control loop

A source generates forward RM-cells which are turned around by the destination and sent back to the source as backward RM-cells. These backward RM-cells carry feedback information provided by the network elements and/or the destination back to the source. A network element may:

- Directly insert feedback control information into RM-cells when they pass in the forward or backward direction
- Indirectly inform the source about congestion by setting the EFCI bit in the data cell header of the cells of the forward information flow. In this case, the destination will update the backward RM-cells based on this congestion information.
- Generate backward RM-cells.

Traffic Management Concepts

This section contains some of the TM concepts in greater detail.

Explicit Forward Congestion Indication

The *Explicit Forward Congestion Indication* (EFCI) is a congestion notification mechanism that is set in the cell header by a network element in an pre-congested or congested state. A network element in an impending congested state or a congested state may set an EFCI in the cell header so that this indication may be examined by the destination end-system. For example, the end-system may use this indication to implement a protocol that adaptively lowers the cell rate of the connection during congestion or impending congestion. A network element that is not in a congested state or an impending congested state will not modify the value of this indication. An impending congested state is the state when a network element is operating around its engineered capacity level.

Cell Loss Priority

For some service categories the end system may generate traffic flows of cells with *Cell Loss Priority* (CLP) marking. A congested network element may selectively discard cells explicitly identified as belonging to a non-compliant ATM connection and/or those cells with their CLP bit set. This is to protect cells without their CLP bit set from being discarded for as long as possible.

Implicit Rate Control

In implicit rate control (binary mode) the EFCI bit in the cell header is checked. If there has been congestion on the forward path (recognized at the destination end station by the EFCI bits of the incoming data cells), the *Congestion Indication* (CI) field within the backward RM cell is marked (set to one). The source end station receives the backward RM cell and acts upon it. If the CI field is set or if RM cells are not returned,

the sending rate is reduced. When the source end station receives a backward RM cell with the CI bit cleared it may increase the sending rate on that particular VC.

Explicit Rate Control Explicit rate control enhances the implicit rate control by adding the *explicit rate* (ER) field to the RM cell. In this field the source end station indicates the rate at which it would like to transmit. If an explicit rate switch exists in the virtual connection (VC) route it may reduce the ER field in the backward RM-cells in case of congestion. In this case it indicates explicit rate for the source end station. The source end station, upon receiving the backward RM-cells, adjusts its sending rate according to the ER field.

The traffic management standard as defined by the ATM forum supports VC routes with both explicit and implicit switches. The standard specifies how to handle lost RM-cells as well as fairness between competing ABR connections and enhancements for better link utilization.

Traffic and Congestion Control Functions

The following describes the available traffic and congestion control functions:

- Network resource management may be carried out by using virtual paths. Virtual path connections may be used to separate traffic, thereby preventing statistical multiplexing with other types of traffic. The CBR and VBR quality of service classes make use of network resource management.
- Connection admission control is defined as the set of actions taken by the network in order to establish whether a virtual channel or virtual path connection can be accepted. The CBR and VBR quality of service classes make use of connection admission control.
- Usage parameter control is defined as the set of actions taken by the network to monitor and control traffic in terms of traffic ordered and validity of the ATM connection at the user access. The CBR and VBR quality of service classes make use of usage parameter control.
- Selective cell discarding by network elements of the CLP=1 flow while still meeting network performance objectives on both the CLP=0 and CLP=1 flows. The VBR quality of service class makes use of selective cell discarding.

- Traffic shaping is a mechanism that alters the traffic characteristics of a stream of cells on a VCC or a VPC to achieve a desired modification of those traffic characteristics. The VBR quality of service class makes use of traffic shaping.
- EFCI is a congestion notification mechanism that the ATM layer service user may make use of to improve the utility that can be derived from the ATM layer. The ABR quality of service class makes use of Explicit Forward Congestion Indication.
- Explicit Rate uses RM-cells to control the traffic rate through the network. The ABR quality of service class makes use of explicit rate.

Traffic Rates Shaping in the 7600 Card

The 7600 Card implements Traffic Management that adheres to the emerging ATM Forum standards. The Traffic Management makes use of RM-cells for flow control to allow large networks to be created around ATM technology without having cell loss due to congestion.

The 7600 Card Traffic Management hardware module contains an ASIC and local memory for traffic management tables. It performs processing on ATM cells emerging from or received by the *ZipChip*. This provides traffic rate shaping, additional statistics and flexibility in ATM network configuration.

The 7600 Card checks connected devices for Traffic Management modules and only activates its own TM module if a corresponding one is found in the connected device.

RM Cell Usage

RM-cells are used by the network to control the rate flow. The RM cell format is as defined in the TM specification. These cells are sent at regular intervals from the 7600 Card and make their way through the network. In the event that there is congestion, the congestion bit of the RM cell is set by the destination end station. The RM cell is then returned to the source 7600 Card. In case the RM-cell is not returned to the source 7600 Card or the CI bit is set, the traffic rate is automatically decreased. A received RM-cell with the CI bit cleared enables the sending 7600 Card to increase its sending rate.

No RM-cells are sent on point-to-multipoint connection. Multicast rates are set in advance to avoid flooding the source with backward RM-cells.

Flow Rate Adjustment Traffic Management in the 7600 Card operates with both EFCI based and Explicit Rate (ER) based flow control methods.

Transmission Rate Profiles The data transmission rate is controlled by means of rate tables called *profiles*. Depending on the information received in the returning RM cells the data transmission rate is indexed up or down in the table. Each table has an upper and lower rate limit according to need. A set of 32 tables is pre-loaded into the system and is designed to cover all requirements of the network. The profiles are identified by their numbers. Please see the manufacturer for the characteristics of each profile.

Dual-Rate Mechanism A dual-rate mechanism is used which depends on whether a single VC is in use or multiple VCs are in use. For a single VC the full rate of 155 Mbps is used; for multiple VCs the maximum rate is set to one-half the full rate.

Static and Dynamic TM In the 7600 Card there are two types of Traffic Management: static and dynamic. The static TM is essentially the dual-rate mechanism described in the previous section. The dynamic TM is the ABR feedback system described in the previous sections. The dynamic TM can be enabled and disabled by the LMA commands. When the dynamic TM is disabled, the static TM continues to operate.

TM Remote Client Database The TM system works independently for each ATM connection. For certain remote clients (LECs) it is desirable to set up special TM characteristics which are used when communicating with it. For this purpose the 7600 Card maintains a database which holds the characteristics of each such connection including:

- Entry index
- TM enable/disable status
- Connection type
- ATM address of the remote LEC
- Profile used when communicating with the remote LEC
- TM rate

The database contents can be displayed on the Management terminal and entries can be added and removed.

Traffic Management in the Network

Figure 13-2 below shows a network scenario, where two 7600 Cards, denoted by source station and destination station are found with an ATM cloud between them. The shaded area between the stations represents a VCC connection over which a data flow and an RM-cell flow takes place as shown. The traffic management is performed as follows:

- 1 A forward RM cell is sent at regular intervals on each VC from the source end station.
- 2 The EFCI bit is set in data cells by the ATM switch when congestion is found along the VC path.
- 3 The destination end station recognizes the EFCI bit and the backward RM cell congestion indicator bit is set.
- 4 The backward RM cell is returned to the source end station through the ATM switch.
- 5 VC traffic flow is altered based on information in the RM cell.

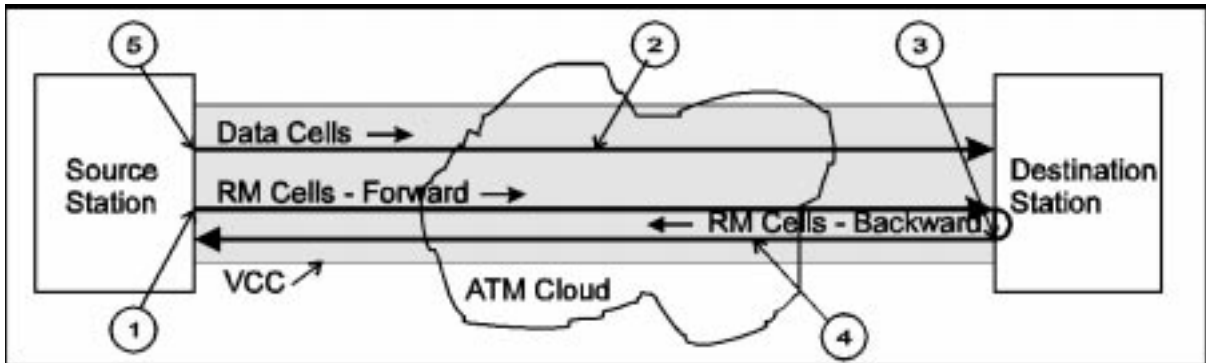

Figure 13-2 Traffic Management control steps

14

DEVICE MANAGEMENT

This chapter explains the applications enabling administrative and management functions in the 7600 Card.

The following topics are discussed:

- The user interfaces and protocols used
- Management types and connection
- Management within the 7600 Card

User Interfaces and Protocols

The following applications provide user interfaces to the 7600 Card:

- 7600 Card administration console - *Local Management* (LM).
- External SNMP-based network management applications, such as Transcend Manager.

The 7600 Card uses virtual terminal protocols, such as rlogin and Telnet in addition to the LM to run the system administration console and SNMP to run the SNMP-based management applications (refer to Figure 14-1).

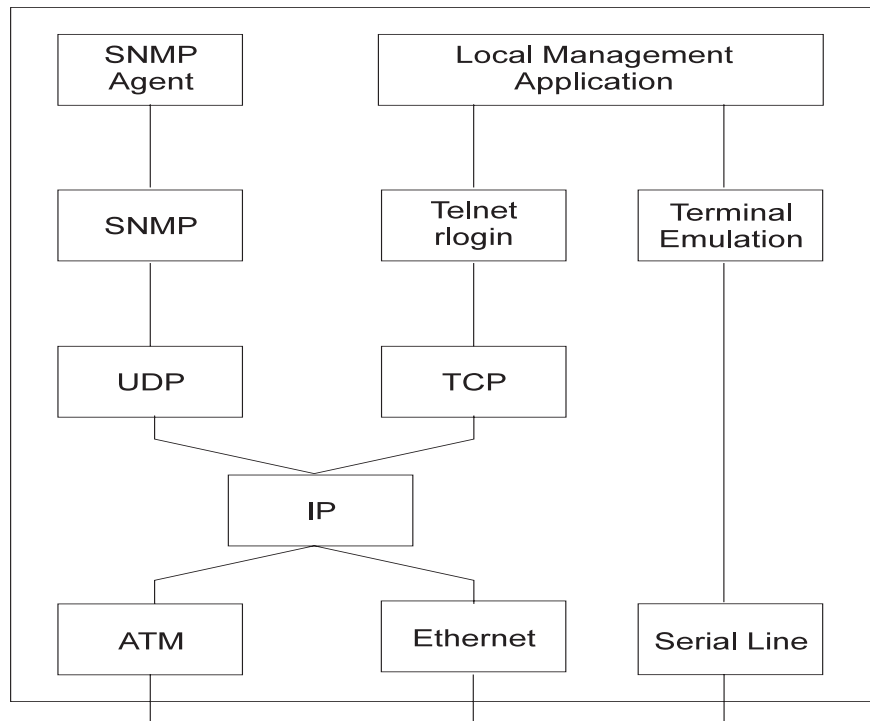

Figure 14-1 User Interfaces and Protocols used to access the 7600 Card

In-Band & Out-of-Band Management

Configuration of the 7600 Card can be performed via an Administration Console or an SNMP-based external network management application running on a workstation.

There are two ways of managing the 7600 Card:

- In-band, using virtual terminal protocols or *SNMP network manager protocol*. Each *SNMP network manager* has its own user interface to the management facilities.
- Out-of-band, by connecting a VT100 terminal (or a PC with terminal emulation software) to the serial port on the CELLplex 7000 unit in which the 7600 Card is installed. The VT100 management interface, which is a menu-driven user interface built into the 7600 Card, is used. This management interface provides many of the same features as SNMP management.

If there is a dedicated network for management data, then the network is being managed *out-of-band*. The advantage of using out-of-band management as opposed to in-band management is that if the data network is faulty, the problem can still be diagnosed because the management requests are sent over a dedicated network. Out-of-band management is, however, a less convenient and more expensive way to access the 7600 Card.

7600 Card Management

The following protocols are used by the 7600 Card to deliver management and administration data to and from the 7600 Card: Local Management (LM), Simple Network Management Protocol (SNMP) and Virtual terminal protocols.

Local Management (LM)

The Local Management (LM) is a character-oriented, menu-driven user interface for performing system-level administration. The 7600 Card's Local Management is performed through the serial connection in the host CELLplex 7000 unit.

The management of all 7600 Cards is supported by the Local Management, regardless of virtual LAN membership.

The Local Management supports the following functions:

- Bridge information and configuration
- ATM information and configuration
- Ethernet information and configuration
- IP configuration
- System configuration
- Virtual LAN and LAN Emulation configuration
- Viewing the statistics and status information
- Viewing the event log

Figure 14-2 shows the connections required to manage the 7600 Card.

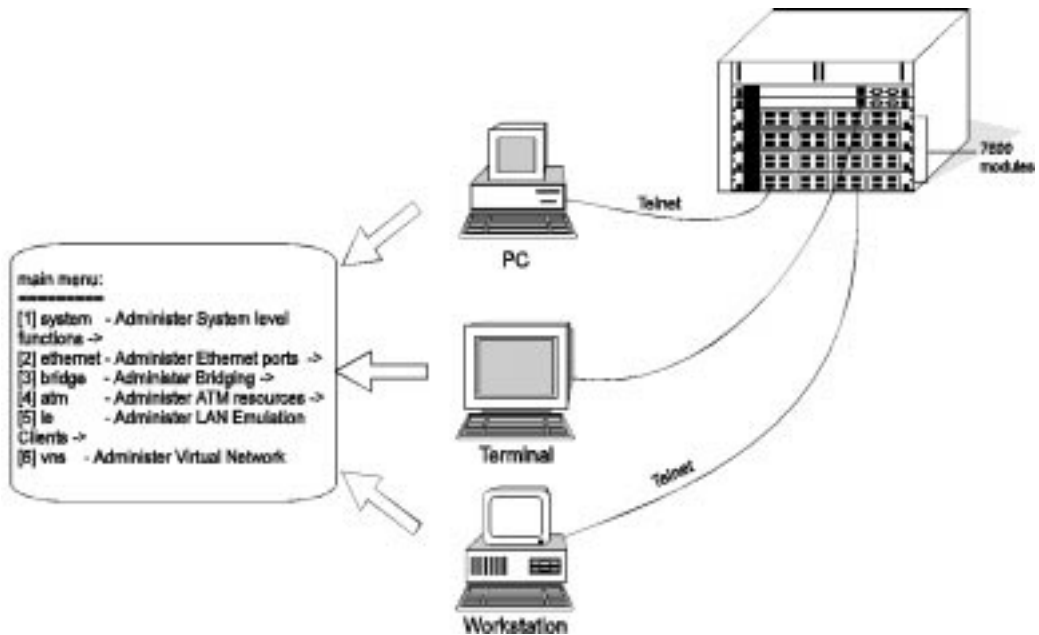

Figure 14-2 7600 Card Administration Console



Even if you wish to use SNMP management, you must first connect a terminal to the serial port, set the VN/bridge configuration, and per bridge IP address and subnet mask.

Simple Network Management Protocol (SNMP)

Simple Network Management Protocol (SNMP) is the standard management protocol for multi-vendor IP networks. Supporting transaction-based queries, SNMP formats messages and transmits information between reporting devices and data-collection programs. It runs on top of the User Datagram Protocol (UDP), offering a connectionless-mode service. This allows SNMP to pass management information before a session is established.

The 7600 Card can be managed through SNMP-based external network management applications running on a workstation. Transcend Enterprise Manager, a network management application from 3Com, manages 7600 Cards by graphically displaying the network. This graphical interface makes it easier to manage large networks (see Figure 14-3).

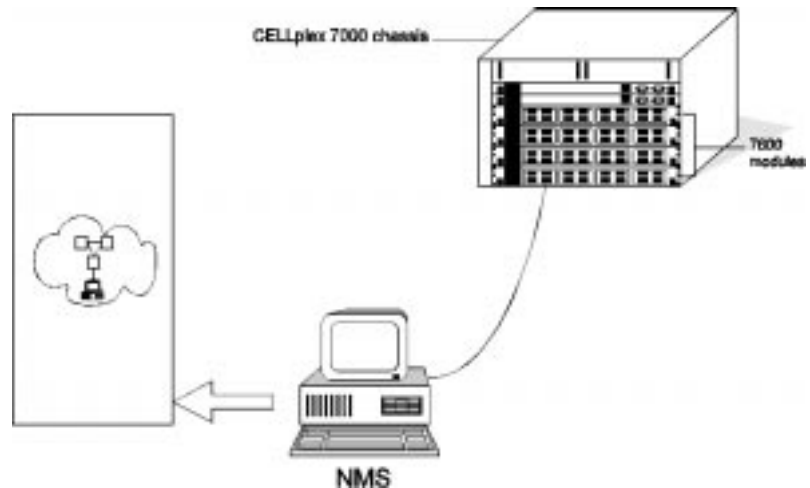

Figure 14-3 Transcend Enterprise Manager (SNMP Manager)

Access to the SNMP agent is in-band via any of the Ethernet segments or ATM port of remote stations. Management of all remote 7600 units is supported by the SNMP agent, regardless of virtual LAN membership.

Since the 7600 Card is standards-based, other SNMP-based applications, such as SunNet Manager or HP OpenView can be used.

The SNMP agent is accessed through any of the 100-BaseT Ethernet ports. It is an in-band connection over IP/Ethernet protocols.

Once the 7600 Card's IP parameters are set, any SNMP-based network manager can manage the unit, provided the Management Information Base (MIB) is installed correctly at the management station.

SNMP Agents

The SNMP agent of the 7600 Card responds to SNMP requests from an external SNMP manager. Each 7600 Card has one SNMP agent which monitors objects on the system and reports data to the Administration Console or a network management system. It acts as an Access Unit (device) agent for managing generic device objects and configuration, and as a proxy for all bridge agents (per VN in a device) for managing bridge-VN specific objects and configuration.

Figure 14-4 shows a 7600 Card being accessed through an SNMP manager, such as Transcend Enterprise Manager.

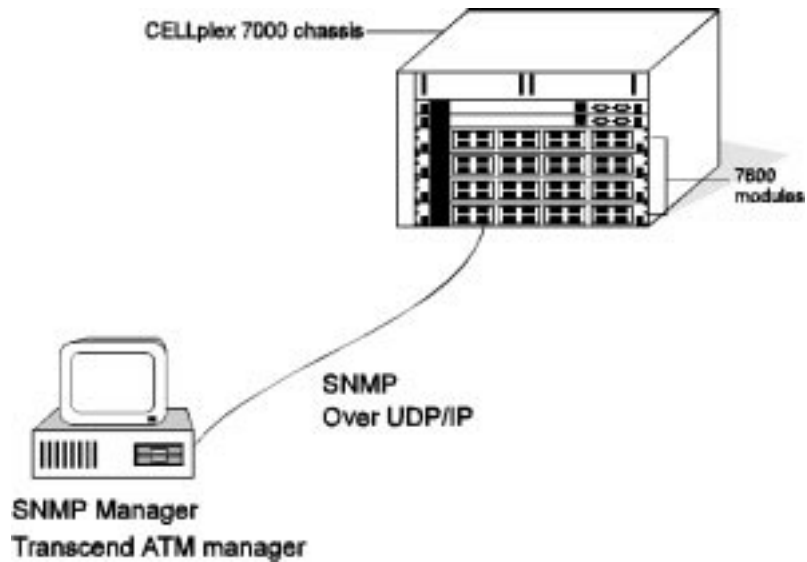

Figure 14-4 SNMP Manager Protocol Access

Management Information Bases (MIBs)

Managed objects are accessed via a virtual information store, termed the Management Information Base (MIB).

Information defined in industry-standard, de-facto standard, and enterprise-specific (private) MIBs supported by the 7600 Card can be accessed. These MIBs are collections of related managed objects (abstract representations of resources that are capable of being managed). Some examples of these resources are error counters, ports, and network policies. The 7600 Card supports the following SNMP MIBs:

- MIB 2
- Bridge MIB
- AToM MIB
- LE Client MIB
- RMON MIB
- Interface Evolution MIB
- NCDCHASS MIB (private)

for managing the ATM port and Virtual LANs.

Security

SNMP security is provided through community strings. A community string is included in each SNMP protocol message sent between external management applications and the 7600 Card.

The default community strings are:

Access Unit agent -

- read : 'public AU'
- write : 'private AU'

Proxy to bridge agents -

- read : 'public'
- write : 'private'

The SNMP agent authorizes requests from the SNMP manager by comparing the community name in the received packet with the community string in the 7600 Card.

Local management security is provided through passwords. Three user access levels exist: read, write, admin.

Virtual Terminal Protocols

A virtual terminal protocol is a software program, such as Rlogin or Telnet, that allows establishment of a management session from a PC or a workstation. Since rlogin and Telnet run over TCP/IP, at least one IP address must be configured on the 7600 Card to access it with a virtual terminal protocol.

Terminal emulation differs from a virtual terminal protocol in that it connects a terminal directly to the serial line (out-of-band).

Figure 14-5 shows a 7600 Card being accessed by a workstation through a virtual terminal protocol and through a terminal.

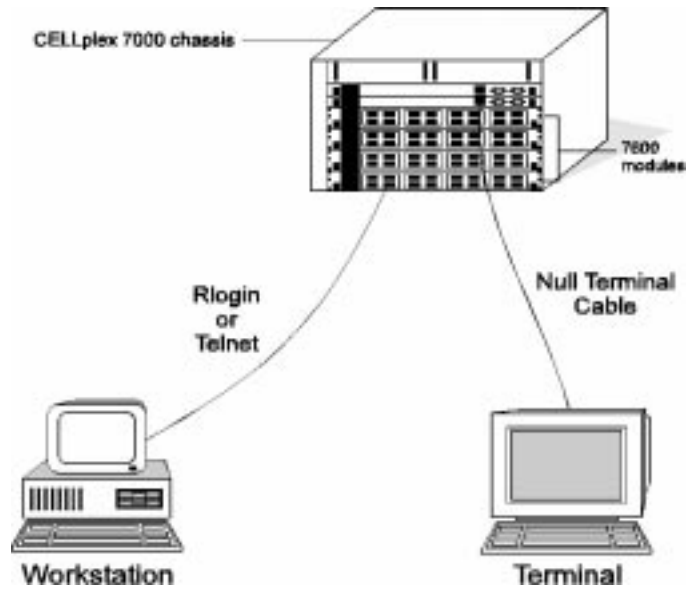

Figure 14-5 Local Management Protocol Access

15

SYSTEM MODES, ATTRIBUTES, AND TUNING

This chapter explains the administrative and management functions in the 7600 Card including system modes, attributes and tuning.

Forwarding Modes

Data frames received from the Fast Ethernet ports pass through the *ZipChip ASIC* and are stored in the shared CRAM (Cell RAM) memory. The CRAM discards all received frames that are not required to be transmitted on any output (filtered frames). The shared memory structure provides for optimal utilization of the available memory. Head of Line blocking, which is caused when frames are queued on input queues, is eliminated by the fact that there is no input queuing on data frames.

Cell Switching

The 7600 Card converts Ethernet frames to ATM sized cells (48 bytes) upon receipt and then uses *cell switching* to forward the frames to their destination addresses. This common format of frames in CRAM makes switching straightforward. CRAM, under control of *ZipChip*, is optimized for storing data cells. Each frame is organized as a linked list of cells. The cells in the CRAM are either converted back to Ethernet frames when transmitted on an Ethernet port or to LAN Emulation frames when transmitted on the ATM port. In this scheme, cell data is never copied because it is converted to the appropriate format by *ZipChip* on its way in and out of CRAM. For more information about Cell Switching in ATM refer to Chapter 5.

As a frame passes through *ZipChip* on its way to CRAM, *ZipChip* makes a forwarding decision for that frame. The 7600 Card supports two forwarding modes which are set individually for Ethernet and ATM:

Store-and-Forward Mode

In store-and-forward mode, the frame cannot be forwarded to its destination address before the last bit has been received. This allows for the rejection of bad frames.

Cut-Through Mode

Cut-through mode enables a frame to be forwarded to a destination address even before the entire frame has been received. You can configure the required number of cells to be received before transmission starts.

Refer to Figure 15-1 for a comparison of Store-and-Forward and Cut-Through modes.

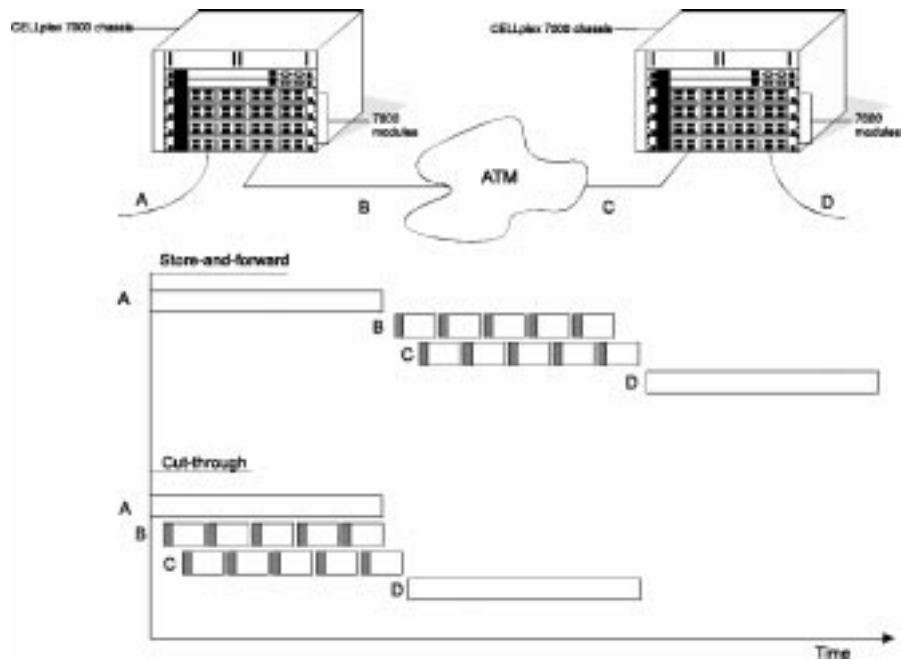

Figure 15-1 Cut-through vs. Store-and-Forward Mode

Timeout Tuning

Timeout tuning is used for assigning timeout delays for both hardware and software. These parameters are used to avoid cells being stuck in the 7600 Card for extended periods of time. This usually occurs when the frame was not assembled correctly and is too long, or the last cell of the frame was not received from the ATM ports. The timeout mechanism only applies to frames arriving from the ATM on their way to the Ethernet ports or the software. The mechanism gets rid of these frames by terminating them as errored frames.

Console Passwords

The Administration Console requires passwords at the various access levels: read, write and admin. Admin access is required to change any of the passwords.

A

Technical Support

3Com provides easy access to technical support information through a variety of on-line and telephone services. This appendix describes these services.

On-Line Technical Services

3Com offers worldwide product support seven days a week, 24 hours a day, through the following on-line systems:

- 3Com Bulletin Board Service (3ComBBS)
- Ask3Com on CompuServe®
- 3ComFacts Automated Fax Service

3Com Bulletin Board Service

3ComBBS contains patches, software, and drivers for all 3Com products, as well as technical articles. This service is available via modem seven days a week, 24 hours a day. To reach the service, set your modem to 8 data bits, no parity, and 1 stop bit. For the telephone number nearest you see Table A-1:

Table A-1 Bulletin Board Service

Country	Baud Rate	Telephone Number
Australia	up to 14400 baud	(61) (2) 955 2073
France	up to 14400 baud	(33) (1) 69 86 69 54
Germany	up to 9600 baud	(49) (89) 627 32 188 (49) (89) 627 32 189
Hong Kong	up to 14400 baud	(852) 537 5601
Italy (fee required)	up to 9600 baud	(39) (2) 273 00680
Japan	up to 14400 baud	(81) (3) 3345 7266
Singapore	up to 9600 baud	(65) 534 5693

Ask3Com on CompuServe

Ask3Com is a CompuServe-based service containing patches, software, drivers, and technical articles about all 3Com products, as well as an interactive forum for technical questions. To use Ask3Com, you need a CompuServe account.

To use Ask3Com:

- 1 Log on to CompuServe.
- 2 Enter go threecom.
- 3 Press Enter to see the Ask3Com main menu.

3ComFacts Automated Fax Service

3Com Corporation's interactive fax service, 3ComFacts, provides data sheets, technical articles, diagrams, and troubleshooting instructions on 3Com products 24 hours a day, seven days a week. Within this service, you may choose to access CardFacts® for adapter information, or NetFacts for network system product information.

- CardFacts provides adapter installation diagrams, configuration drawings, troubleshooting instruction, and technical articles. Document 9999 provides you with an index of adapter documents.
- NetFacts provides data sheets and technical articles on 3Com Corporation's hub, bridge, router, terminal server, and software products. Document 8888 provides you with an index of system product documents.

Call 3ComFacts using your touch-tone telephone. International access numbers are found in Table A-2.

Table A-2 Automated Fax Service

Country	Fax Number
Hong Kong	(852) 537 5610
U.K.	(44) (1442) 278279
U.S.	(1) (408) 727 7021

Telephone Support

Telephone support is available from both 3Com and your network supplier.

Support from 3Com

If you are unable to receive support from your network supplier, technical support contracts are available from 3Com.

In the U.S. and Canada, call (800) 876-3266 for customer service.

If you are outside the U.S. and Canada, contact your local 3Com sales office to find your authorized service provider. For the telephone numbers see Table A-3.

Table A-3 Telephone Support

Country	Telephone Number	Country	Telephone Number
Australia (Sydney)	(61) (2) 959 3020	Mexico	(525)531 0591
(Melbourne)	(61)(3)653 9515	Netherlands	(31)(3)40255033
Belgium	(32)(2)716 4880	Singapore	(65)538 9368
Brazil	(55)(11)241 1571	South Africa	(27)(11)803 7404
Canada	(905)882 9964	Spain	(34)(1)383 1700
France	(33)(1)698 66800	Sweden	(46)(8)632 9100
Germany	(49)(89)627 320	Taiwan	(886)(2)577 4352
Hong Kong	(852)868 9111	United Arab Emirates	(971)(4)349049
Italy	(39)(2)273 02041	U.K.	(44)(1628)897 000
Japan	(81)(3)3345 7251	U.S.	(1)(408)492 1790

**Support from Your
Network Supplier**

If additional assistance is required, contact your network supplier. Many suppliers are authorized 3Com service partners who are qualified to provide a variety of services, including network planning, installation, hardware maintenance, application training, and support services.

When you contact your network supplier for assistance, have the following information ready:

- Diagnostic error messages.
- A list of system hardware and software, including revision levels.
- Details about recent configuration changes, if applicable.

If you are unable to contact your network supplier, refer to Table A-4 on how to contact 3Com.

Table A-4 Network Supplier Support

Country	Baud Rate	Telephone Number
Taiwan	up to 14400 baud	(886) (2) 377 5838 (886) (2) 377 5840
U.K.	up to 14400 baud	(44) (1442) 278278
U.S.	up to 14400 baud	(1) (408) 980 8204

Returning Products for Repair

A product sent directly to 3Com for repair must first be assigned a Return Materials Authorization (RMA) number. A product sent to 3Com without an RMA number will be returned to the sender unopened, at the sender's expense.

Table A-5 contains the telephone and fax numbers to use, to obtain an RMA number.:

Table A-5 Obtaining an RMA Number

Country	Telephone Number	Fax Number
U.S. and Canada	(800) 876 3266, option 2	(408) 764 7120
Europe	(44) (1442) 278000	(44) (1442) 236824
Outside Europe, U.S. and Canada	(1) (408) 492 1790	(1) (408) 764 7290

Table A-6 lists the local access numbers available within the following countries:

Table A-6 Local Access Numbers

Country	Fax Number	Country	Fax Number
Australia	800 123853	Italy	1678 99085
Denmark	800 17319	Netherlands	06 0228049
Finland	98 001 4444	Norway	05 01 1062
France	05 90 81 58	Sweden	020 792954
Germany	0130 8180 63	U.K.	0800 626403

B

TROUBLESHOOTING

This chapter explains how to identify and correct problems, and how to perform related diagnostic tasks, such as replacing fuses and cleaning fiber optic cables.

If you have problems that are not addressed in this chapter, contact 3Com Technical Support or your service person. For Technical Support information, see Appendix A: *Technical Support*

Solving Common Problems

Following are common problems which may arise while working with the 7600 Card. If your problem does not appear on this list, you may want to view relevant statistics and parameters using the Administration Console menus (refer to *CELLplex 7000 Administration Guide*). You can also contact 3Com Technical Support or your service person (refer to *Appendix E-Technical Support*). Also, be sure to read through the release notes.

Terminal Does Not Show Anything

If the control terminal is physically connected to the module, but does not load the Administration Console Menus, verify that your terminal setup matches the specifications in the *Connecting to the Control Terminal* section in *Chapter 1*. Also, make sure your cable is configured as DTE.

ACT LED Not Blinking

When the CELLplex 7000 is activated, the ACT LEDs on the 7600 Card should be blinking. If not, verify that the module is properly inserted into the chassis of the CELLplex 7000.

Ethernet Forwarding Failures (Fx port)

Verify that the Link Status LED is lit green. If not, reconnect the Tx side of the connection. If that does not eliminate the problem, check that the connector on the Rx side is properly inserted.

If the Link Status LED is lit, check that the port through which you are trying to forward data has been enabled. If it has been enabled, check

the cabling and connections at the port. Try sending the data through another port: if you can forward data through the unit via another port, it indicates a local problem with the first port. Re-examine cabling connections.

If you still cannot resolve the problem, contact your supplier.

Related Diagnostic Procedures

When troubleshooting for problems, you may have to perform minor procedures to help correct the problem. These procedures are described below. For more complex operations on the 7600 Card, contact your service person.

Cleaning Dirty Fiber Optic Cables

Fiber optic transceivers are sensitive optical devices that need to be handled carefully. If dirt collects on the fiber optic lens, you may notice that the LED for an ATM port link status does not light. You may also notice degraded performance of that port, indicated by an increase in the physical layer statistics count for that port.

To prevent dust from collecting on the fiber optic lens, keep the dust covers on the ports at all times when they are not in use. To clean a fiber optic lens, follow the procedure below:

- 1 Remove any accumulated dust or debris from the port or connector by blowing off all surfaces with a canned air duster.

Compressed gas is recommended, such as Chemtronics' Ultrajet® or the Triangle Tool Group's Liqui-Too!™ Dust-A-Way. Do not use commercial compressed air or "house air" because of the risk of oil contamination.
- 2 Reconnect the cable to the port to see if the dusting corrected the problem.
- 3 If the LED still does not appear, or if it lights yellow, continue with steps 5 and 6.
- 4 Gently wipe the ports with a lint-free, nonabrasive, non-adhesive swab. Microswabs™ by Texwipe™ are recommended.
- 5 Gently wipe the connectors with a lint-free, nonabrasive wipe or pad. Texwipe™ pads are recommended.



Avoid touching all surfaces after cleaning the connectors, and keep all unused ports covered.



Ne toucher aucune surface après le nettoyage des connecteurs et garder les pièces inutilisées couvertes.



Vermeiden Sie das Berühren aller Oberflächen nach dem Säubern der Kontakte und verdecken Sie alle nicht benutzten Öffnungen.

C

7600 FAST ETHERNET CARD SPECIFICATIONS

This chapter contains the specifications of the 7600 Card.

Physical

Height	1¾ in	4.5 cm
Width	17 in	39.5 cm
Depth	11 in	23.5 cm
Weight	±3.3 lb	±1.5 kg

Interfaces

- Fast Ethernet
8 or 16 100Base-Fx or 100Base-Tx Ports
- Management
1 RS-232 port on CELLplex 7000 switch

Fast Ethernet Switching

- Auto-sensing full duplex/half duplex
- Software-selectable, cut-through or store-and-forward mode
- Auto sensing 10/100 Mbps
- Rate-based flow control
- Full rate multicast support
- Address table capacity of up to 32k entries
- Full rate forward/filter
- IEEE 802.1D Spanning Tree protocol (STP) support
- Virtual LAN support

- LAN Emulation Client (LEC) support
- Local management via the CELLplex 7000's RS-232 port
- Congestion management
- MIBs supported: MIB2, Bridge MIB, AToM MIB, LEC MIB, RMON MIB, Interface Evolution MIB, NCDCHASS MIB (private)

Environmental

- Operating Temperature
32° to 104° F (0° to 40° C)
- Operating Humidity
10% to 90% non-condensing
- Storage Temperature
-4° to 167° F (-20 to 75° C)
- Storage Humidity
10% to 95% non-condensing

Indicators

- Fast Ethernet Ports per-port link status and transmit
- UnitPower, fail, activity

Management

- In-band SNMP over Ethernet
- Local Management via CELLplex management
- ILMI and OAM support
- MIBs supported:
 - MIB 2
 - Bridge MIB
 - AToM MIB
 - LE Client MIB
 - RMON MIB
 - Interface Evolution MIB
 - NCDCHASS MIB (private)

Standards Compliance

- Safety**
- Agency Certifications:
UL 1950, CSA 22.2 No. 1950,
EN 60950, IEC 825-1 825-2,
PCB UL 94V-0,
PCB ANSI/IPC-RB-276 class 2
 - Designed to Comply with VDE 0871 part 2 class A, EN 55022
 - AC Protection 20 amp circuit breaker

- Electromagnetic Emissions (Agency Certifications)**
- Meets FCC part 15, Subparagraph B, Class A limits, and CISPR-22 Class A limits
 - Directive complied with: EMC 89/336/EEC as amended by 92/31/EEC and 93/68/EEC.
- Emission: EN50081-1 (EN55022 Class A)
Immunity: EM50082-1 (IEC801-2,-3,-4)

Communications Protocols RFC 826 ARP, RFC 791 IP, RFC 792 ICMP, RFC 768 UDP, RFC 793 TCP

Management Protocols RFC 1157 SNMP, RFC 1213 MIB2, RFC 1212 Concise, RFC 1212 Traps, RFC 1695 ATOM MIB

GLOSSARY

7600 Card	A 36-port ATM/Ethernet interface card in the CELLplex 7000 chassis.
Asynchronous Transfer Mode (ATM)	A transfer method used for LAN and WAN. ATM carries voice, video, and data at speeds up to 2.2 Gbps and can integrate geographically distant disparate networks. Also called cell relay.
ATM Adaptation Layer (AAL)	A set of protocols that translate user higher-layer protocols into ATM format.
ATM Forum	A consortium of vendors, carriers, and users formed to expedite industry agreement on ATM interfaces.
ATM Layer	The part of the BISDN protocol stack that handles most of the ATM routing and processing.
ATM Member	An alias given to an ATM address on a specific port in order to avoid typing in the ATM address 20 octets long.
AU ID	Unique number assigned to the 7600 Card. May be found through the Administration Console Menus of the LinkSwitch.
backbone	The main segment of a campus network, to which are attached department networks, or ribs.
Broadcast and Unknown Server (BUS)	The Broadcast and Unknown Server handles data sent by a LEC to the broadcast MAC address, all multicast traffic, and initial unicast frames which are sent by a LEC before the data direct ATM address has been resolved.
broadcasting	A common method of information transmission in which every port on the network receives the packet being sent, though only the port with the proper address passes it on to the user.
bridge	Device connecting between two networks which filters and forwards data between the networks according to their destination address.

cell	An ATM Layer protocol data unit (PDU) characterized by fixed, rather than variable, length payloads. The standard ATM cell is 48 bytes of payload with 5 bytes of header.
CELLplex 7000 Switch	A high-performance, modular ATM switch.
Cell Loss Priority (CLP)	A bit in the ATM cell header indicating that if there is a need to discard a cell, the cell with the CLP bit marked is to be discarded.
collision	Overlapping transmission of two or more nodes onto media. All data is unusable.
connection	An ATM connection consists of the concatenation of ATM Layer links in order to provide an end-to-end information transfer capability to access points.
connectionless communications	A form of packet-switching that relies on global addresses in each packet rather than on predefined virtual circuits.
connection-oriented communications	A form of packet-switching that requires a predefined circuit from source to destination to be established before data can be transferred.
Data Communications Equipment (DCE)	The equipment providing functions that establish, maintain and terminate a data transmission connection.
Data Terminal Equipment (DTE)	The equipment connected to the common carrier communications facility. The DTE is typically a computer system or terminal.
end system	A system where an ATM connection is terminated or initiated. An originating end system initiates the ATM connection, and a terminating end system terminates the ATM connection.
Ethernet	A CSMA/CD, 10 Mbps, local area data network, developed by Xerox Corporation. It is one of the most popular LANs in use.
header	Protocol control information located at the beginning of a protocol data unit.
IEEE 802.3	IEEE standard for Ethernet local area networks.
IEEE 802.1d	IEEE standard for bridging.

in-band	Transmission of auxiliary information, e.g., management messages over the media also used by the system users.
Internet Protocol (IP)	The protocol governing packet forwarding within the Transmission Control Protocol/Internet Protocol (TCP/IP) suite of standards developed and used on the Internet.
Internet Protocol address (IP address)	A unique identifier for a machine attached to a network made up of two or more interconnected local area or wide area networks.
Local Area Network (LAN)	A data communications network spanning a limited geographical area, such as a single building or campus. It provides communication between computers and peripherals. LANs are distinguished by their small geographical size, high data rate, and low error rate.
LAN Emulation	A way for legacy LANs and all higher-layer protocols and applications to integrate transparently with ATM networks.
LAN Emulation Client (LEC)	The LAN Emulation Client is the entity in end systems which performs data forwarding, address resolution, and other control functions.
LAN Emulation Configuration Server (LECS)	Assigns individual LECs to different Emulated LANs. The LECS allows the LEC to automatically configure.
LAN Emulation Server	Implements the control coordination function for the Emulated LAN. In addition, it provides a facility for registering and resolving MAC addresses and/or route descriptors to ATM addresses.
LinkSwitch 2700	3Com Ethernet-to-ATM switch used to connect Ethernet network devices to each other and to an ATM backbone.
LM	Local management of a network device, via a connected terminal.
Management Information Base (MIB)	A database of network management information that describes the specifics of individual network components.
Network to Network Interface (NNI)	The interface between two ATM network nodes.
Operation and Maintenance cell (OAM)	A cell that contains ATM maintenance and performance monitoring information. It does not form part of the upper layer information transfer.

out-of-band	Transmission of auxiliary information e.g., management messages, over a media other than that used by the system users.
point-to-point call	A two-way call or connection that has one source and one destination.
point-to-multipoint call	A one-way call or connection that has only one source, but may have many destinations.
protocol	A set of rules for communicating between communication devices. The rules dictate format, timing, sequencing, and error control.
Protocol Data Unit (PDU)	A unit of data specified in a layer protocol and consisting of protocol control information and layer user data.
Permanent Virtual Connection (PVC)	. A basic connection method that requires the user to define each connection manually.
router	A device that connects two or more remote networks by selectively forwarding messages between them. A router differs from a bridge in that it selectively forwards information between the networks, based on layer 3 protocols.
RJ-21port	50-pin Telco connector on 7400 Interface Card that supports 12 10BaseT ports for high-density connections.
server	A computer that provides clients with application and network services. Servers are shared by multiple users.
Simple Network Management Protocol (SNMP)	A protocol originally designed to be used in managing TCP/IP-based internets. SNMP is presently implemented on a wide variety of computers and networking equipment and may be used to manage many aspects of network and end-station operation.
Switched Virtual Connection (SVC)	An ATM standard signaling protocol that automatically defines connections as they are needed, and discards them when desired.
topology	The physical or logical placement of stations on a network in relation to one another.
Virtual Channel Identifier (VCI)	Part of the identifier of a particular virtual circuit in the ATM fabric.
Virtual Path Identifier (VPI)	Part of the identifier of a particular virtual circuit in the ATM fabric.

User Network Interface (UNI) The UNI interconnects an ATM user with an ATM switch.

Wide Area Network (WAN) Data communications network spanning very large geographical areas.

INDEX

Numbers

- 100BASE-Fx 2-5
 - 100BASE-Fx port 1-1
 - 100BASE-Tx 2-5
 - 100BASE-Tx port 1-1
 - 3Com Bulletin Board Service A-1
 - 3ComFacts Automated Fax Service A-2
 - 7600 Card
 - bridge setup 12-18
 - 7600 Fast Ethernet Interface Card
 - About This Guide 1
 - Functional Overview 1-1
-

A

- AAL5 layer
 - octets 7-2
 - unicast frames 7-2
- AC protection C-3
- access unit
 - community strings 14-7
 - SNMP agent 14-5
- active LED not blinking B-1
- active LEDs
 - system status 2-8
- address resolution 12-12
- Admin vLAN management
 - configuring 3-9
- administration console 14-1
 - management capabilities 4-1
 - menu system 4-1
- administrative status
 - ATM port 7-2
 - enable on ATM port 7-9
 - Fast Ethernet port 6-3
- agency certifications C-3
- aging time
 - Bridge 6-9
 - LE_ARP cache 12-14
 - LEC 8-8, 12-17
- allowed ports 11-8
- Ask3Com on CompuServe A-2
- ATM
 - basic concepts 12-2
 - cell switching 12-2

- fixed length cell 12-2
 - ILMI MIB 12-4
 - internal connection 5-2
 - protocol stack layer 12-2
 - ATM Adaptation Layer, see AAL
 - ATM address
 - BUS 8-5, 12-10
 - LECS 8-4, 8-6, 12-9
 - LES 8-4, 8-5, 12-10
 - ATM port
 - administrative status 7-2
 - enable administrative status 7-9
 - octets 7-2
 - operational status 7-2
 - statistics 7-2, 7-3
 - unicast 7-2
 - Auto-sensing 1-4
-

B

- blocking
 - static address on port 6-19, 11-8
- Bridge
 - aging time 6-9
 - attaching Fast Ethernet port to 5-2
 - attaching internal ATM port 5-3
 - attributes and statistics 6-8
 - Fast Ethernet port assigned to 5-2
 - Forwarding database 6-12
 - forwarding logic 12-14
 - in 7600 Card 12-10
 - learned discards 6-9
 - MAC address 6-9
 - STP Attributes 6-22
- Bridge ATM address
 - display 7-3
 - ILMI state 7-4
 - update 7-4
- Bridge parameters
 - port-dependent 11-11
 - port-independent 11-11
- Bridge port
 - delay discarded frames 6-11
 - disable for management 6-27
 - discarded frames 6-10
 - excessive discarded frame 6-11

- Forwarding database 6-12, 6-14
- frame traffic statistics 6-10
- frames 6-10
- mapping to Ethernet ports 6-8
- number 6-9
- STP Attributes 6-26
- Bridged-LAN environments 11-12
- Broadcast and Unknown Server, see BUS
- broadcast attributes
 - display 6-5
 - updating 6-6
- broadcast throttling
 - disabling 6-6
- Bulletin Board Service A-1
- BUS
 - ATM address 8-5
 - configuration information 8-4
 - multicast forward VCC 8-5, 12-10
 - multicast send VCC 8-5, 12-10
 - unicast frames 8-17, 8-18

C

- cable type
 - shielded twisted pair (STP) 11-4
 - unshielded twisted pair (UTP) 11-4
- card specifications
 - specifications C-1
- Carrier Sense Multiple Access with Collision Detection, see CSMA/CD
- cell
 - discarding 13-4
- cell switching 12-11
- cleaning dirty fiber optic cables B-2
- cleaning fiber optic transceivers B-2
- communications protocols C-3
- community strings
 - access unit 14-7
 - proxy to bridge agent 14-7
 - SNMP security 14-7
- CompuServe, Ask3Com A-2
- config VCC
 - LECS 8-4, 12-9
- configuring
 - 7600 Card 2-5
 - Admin vLAN management 3-9
 - default gateway 3-10
 - ELANs 3-10
 - IP address 3-10
 - LE Client 3-8
 - LE parameters 3-7
 - LECS address 3-7
 - management 3-10
 - network prefix 3-6
 - UNI/NNI parameters 3-7

- Virtual LAN 3-8, 3-10
- connecting
 - local management terminal 2-6
 - network devices 2-5
- connection
 - RS-232 2-6
 - via the CELLplex 7000 switch 2-6
- connection status 2-9
- connector
 - SC 2-5
 - STP 2-5
- console event messages
 - disabling 10-14
- console password 15-3
- context 3-10, 4-3
 - changing 4-3
- control direct VCC
 - LES 8-5, 12-10
- control distribute VCC
 - LES 8-5, 12-10
- control information
 - in-band 12-16
- control time-out
 - LEC 12-16
- conventions
 - notice icons, About This Guide 2
 - typographical 2
- CSMA/CD 11-1
- cut-through mode 10-7, 15-2

D

- default gateway 9-2
 - configuring 3-10
- disable
 - Bridge port 6-27
 - broadcast throttling 6-6
 - console event messages 10-14
 - Fast Ethernet port 6-5, 11-5
 - STP 6-21, 11-10
- discarding cells 13-3
- display
 - ATM port attributes and statistics 7-2
 - Bridge ATM address 7-3
 - Bridge attributes and statistics 6-8
 - Bridge STP attributes 6-22
 - broadcast attributes 6-5
 - context 4-3
 - current LEC configuration 8-4
 - Fast Ethernet port attributes 6-2
 - FDB entries 6-12
 - FDB learned entries 6-14
 - frame traffic statistics on Bridge port 6-10
 - hardware configuration 10-5
 - IP configuration 9-2

- LEC control-frame statistics 8-14
- LEC operational parameters 8-8
- LEC statistics 8-2
- main menu 4-1
- SNMP configuration 9-4
- software download status 10-3
- software time-out parameters 10-8
- software version 10-2
- STP attributes for Bridge port 6-26
- STP enable status 6-21
- time-out delays 10-11
- traffic management clients 7-6
- traffic management configuration 7-5

display FDB static entries 6-15

documentation

- how to read 2
- road map 3

E

ELAN

- assigning name to 5-2
- Components 12-5
- configuring 3-10
- connected to Bridge 5-2
- connections 12-7
- corresponding to vLAN 12-18
- data transmission on 12-15
- update name 8-6

ELAN name

- LES 12-9

electromagnetic emissions standards C-3

Emulated LAN, see ELAN

environmental specifications C-2

ethernet forwarding failure B-1

Ethernet switching

- features 1-4
- specifications C-1

Explicit Forward Congestion Indication

- traffic management 13-3

explicit rate control

- traffic management 13-4

F

fail LEDs

- system status 2-8

Fast Ethernet

- LAN 11-2

- LED display 2-8

- physical modules 1-1

- status indicators 2-8

Fast Ethernet backbone 1-5

Fast Ethernet port

- 10/100 Mbps transmission speed 11-3

- administrative status 6-3

- assigned to Bridge 5-2

- attaching to Bridge 5-2

- attributes and statistics 6-2

- auto-negotiation 11-2

- autonegotiation 6-7

- broadcast frames 6-3

- capabilities 11-2

- configuration 1-1

- context 3-10, 4-3

- disabling 6-5, 11-5

- discarded frames 6-3

- duplex mode 6-7

- errored frames 6-3

- full/half duplex transmission mode 11-2

- Fx connection 1-3

- indicators C-2

- link status 2-9

- MAC address 6-3

- mapping to Bridge ports 6-8

- monitoring 11-5

- multicast frames 6-3

- numbering 1-1

- octets 6-3

- packet status 2-9

- speed 6-7

- Tx connection 1-3

- unicast frames

- unknown frames 6-4

- updating attributes 6-7

fax service A-2

flash memory

- reset 10-12

flooding mode 12-14

flush protocol 12-16

forward-delay-time

- LE_ARP cache 12-14

Forwarding database 11-7

- add static address 6-19

- allowed-to static entries 6-16

- blocking static address 6-19

- Bridge 6-12, 6-14

- Bridge port 6-12, 6-14

- display all entries 6-12

- display learned entries 6-14

- display static entries 6-15

- entry status 6-16

- MAC address 6-12, 6-14, 6-16

- member ID 6-16

- received port static entries 6-16

- remove static address 6-20

- status 6-12

forwarding logic

- Bridge 12-14

forwarding modes 15-1

frame traffic statistics 6-10
 front panel
 with physical modules 1-1
 functional overview 1-1

G

guide
 scope 1
 typographical conventions 2

H

hardware configuration 10-5
 hardware time-out delay 10-11, 15-2
 update 10-11
 hardware time-out parameters 10-8
 how to read documentation 2
 humidity
 operating C-2
 storage C-2

I

implicit rate control
 traffic management 13-3
 in-band management 14-2
 indicators
 specifications C-2
 installing
 7600 Card 2-4
 Fast Ethernet physical module 2-5
 integrated setup
 operation 3-5
 internal ATM port
 attaching to Bridge 5-3
 IP address 9-2
 configuring 3-10
 IP configuration 9-2
 Bridge 9-2

L

LAN
 Fast Ethernet 11-2
 LAN Emulation
 components see LE components
 LAN Emulation Address Resolution Protocol, see LE_ARP
 LAN Emulation Client, see LEC
 LAN Emulation Server, see LES
 LE Client
 configuring 3-8
 LE parameters
 configuring 3-7
 LE_ARP 12-12

LE_ARP cache
 aging 12-14
 aging time 12-14
 LE_ARP response 12-12
 LE_ARP, see LAN Emulation Address Resolution Protocol
 learning addresses 12-13
 learning station addresses 11-7
 LEC 12-6
 aging time 8-8, 12-17
 broadcast frames 8-2
 configuration and status 8-4, 12-9
 connection state 8-2
 control frame statistics 8-14
 control time-out 12-16
 control-frame statistics 8-14
 discards 8-3
 errored frames 8-3
 forward delay time 8-8
 ID 8-4
 multicast frames 8-2
 octets 8-2
 operational parameters 8-8
 parameters 12-16
 proxy 12-13
 state 8-2
 statistics 8-2
 topology change flag 8-8
 unicast frames 8-2
 unknown frames 8-3
 VCC time-out 12-17
 LEC control-frame statistics
 reset 8-17
 LEC ID
 LES 12-9
 LECS
 ATM address 8-4, 8-6
 LAN Emulation Configuration Server, see LECS
 ATM address via ILMI 8-7
 config VCC 8-4, 12-9
 configuration information 8-4
 LECS address
 configuring 3-7
 LED display 2-7
 LEDs 1-3
 LES
 ATM address 8-4, 12-10
 configuration information 8-4
 control direct VCC 8-5, 12-10
 control distribute VCC 8-5, 12-10
 ELAN name 12-9
 LEC ID 12-9
 populating directory 12-13
 LES ATM address
 update 8-7
 LES directory

- populating 12-6
- Link status 2-9
- LM security 14-7
- local management terminal 2-6
- Local Management, see LM
- locating information in documents 3

M

- MAC address 6-3, 12-13
 - Ethernet ports 6-3
 - Forwarding database 6-12, 6-14, 6-16
- management
 - configuration 3-10
 - in-band 14-2
 - out-of-band 14-2
 - specifications C-2
- Management Information Base C-2
 - supported MIBs 14-6
- management protocols C-3
- Maximum Transfer Unit, see MTU
- maximum-unknown-frame-count. 12-15
- maximum-unknown-frame-time 12-15
- menu system 4-1
- menus
 - access to submenus 4-4
 - key functions 4-4
 - selecting options 4-3
- MIB 14-6
- MIBs supported 1-4
- multicast forward VCC
 - BUS 12-10
- multicast frames 12-16
- multicast send VCC
 - BUS 12-10

N

- network devices 2-5
- network prefix
 - configuring 3-6
- network resource management
 - traffic management 13-4
- Network to Network Interface, see NNI
- NMS IP address
 - update 9-5
- NNI
 - in ATM 12-2
- normal operation 2-8

O

- octets
 - ATM port 7-2
- On-Line Technical Services A-1

- 3Com Bulletin Board Service A-1
- 3ComFacts Automated Fax Service A-2
- Ask3Com on CompuServe A-2
- operating humidity C-2
- operating temperature C-2
- operational status
 - ATM port 7-2
 - port 6-3
- out-of-band management 14-2

P

- Packet status 2-9
- password
 - admin-access 10-14
 - read-access 10-13
 - write-access 10-13
- passwords 14-7, 15-3
- Permanent Virtual Channels, see PVC
- physical module 1-1
- physical specifications C-1
- populating LES directory 12-13
- port state
 - blocking 11-8
 - learning 11-10
 - listening 11-10
- port status
 - operational 6-3
- power LEDs
 - system status 2-8
- power-on self-test 2-8
- power-up phase 2-8
- protocol
 - communications C-3
 - management C-3
- protocol stack
 - ATM layer 12-2
- protocols
 - virtual terminal 14-7
- proxy LEC 12-13
- proxy to bridge agent
 - community strings 14-7

R

- ready frames 12-16
- reboot 10-15
- registering MAC addresses 12-13
- repairing products A-4
- Resource Management cell usage 13-5
- Resource Management Cells, see RM-cells
- returning products for repair A-4
- RJ-45 connector 1-3
- rlogin 14-1
- RM-cells 13-1

road map of documentation 3

S

- safety precautions 2-1
 - safety standards C-3
 - SC connector 1-3
 - scope of this guide 1
 - security
 - SNMP 14-7
 - selective cell discarding 13-4
 - Serial Port Settings 2-6
 - server farm 1-7
 - setup
 - full 3-2
 - integrated 3-2
 - multi-context 3-10
 - switch 3-2
 - Simple Network Management Protocol (SNMP) 14-3
 - Simple Network Management Protocol, see SNMP
 - SNMP
 - overview 14-4
 - SNMP agents
 - SNMP configuration 9-4
 - Bridge 9-4
 - NMS address 9-4
 - SNMP security
 - community strings 14-7
 - software
 - erase from flash 10-4
 - software download
 - from local 10-4
 - from network 10-3
 - TFTP 10-3
 - software time-out delay 10-11, 15-2
 - update 10-12
 - software time-out parameters 10-8
 - software version
 - display 10-2
 - Spanning Tree Protocol
 - disabling 11-10
 - overview
 - path between LANs 11-9
 - reconfiguring 11-10
 - specifications
 - communications protocols C-3
 - electromagnetic emissions standards C-3
 - environmental C-2
 - Ethernet switching C-1
 - indicators C-2
 - interfaces C-1
 - management C-2
 - management protocols C-3
 - physical C-1
 - safety standards C-3
 - standards compliance C-3
 - standards compliance C-3
 - static addresses 11-8
 - permanency 11-8
 - statistics
 - ATM port 7-2, 7-3
 - Bridge 6-8
 - Fast Ethernet port 6-2
 - frame traffic on Bridge port 6-10
 - LEC 8-2
 - LEC control-frame 8-14
 - link and physical layer parameters at UNI 12-4
 - reset LEC control-frame 8-17
 - traffic rate 13-5
 - status
 - Forwarding database 6-12
 - storage humidity C-2
 - storage temperature C-2
 - store-and-forward
 - in Bridge 11-6
 - mode 10-7, 15-1
 - STP
 - disable 6-21
 - display attributes 6-22
 - display enable status 6-21
 - STP attributes
 - display for Bridge-port 6-26
 - update Bridge-forward-delay 6-25
 - update Bridge-hello-time 6-24
 - update Bridge-priority 6-24
 - STP Bridge-port attributes
 - update Bridge-path-cost 6-28
 - update Bridge-port-priority 6-27
 - STP, see Spanning Tree Protocol
 - subnet mask 9-2
 - update 9-4
 - support
 - from 3Com A-3
 - from network supplier A-3
 - supported MIBs C-2
 - system administration console 14-1
 - system configuration mode 10-6
 - system state
 - hardware fault 2-7
 - normal operation 2-7
 - power-up 2-7
 - software fault 2-7
 - system states 2-7
-
- ## T
- technical support A-1
 - telephone support A-2
 - support from 3Com A-3
 - support from network supplier A-3

Telnet 14-1
 temperature
 operating C-2
 storage C-2
 TFTP software download 10-3
 time-out
 display 10-11
 time-out tuning 15-2
 traffic management 13-3
 connection admission control 13-4
 control cells 13-1
 display clients 7-6
 display configuration 7-5
 enabling 7-6
 Explicit Forward Congestion Indication 13-3
 explicit rate control 13-4
 flow control 13-2
 flow rate adjustment 13-6
 implicit rate control 13-3
 network resource management 13-4
 overview 13-1
 selective cell discarding 13-4
 standard 1-5
 traffic shaping 13-5
 usage parameter control 13-4
 traffic rates shaping 13-5
 definition 13-5
 traffic status 2-9
 Transcend Enterprise Manager 1-5
 transparent bridge 11-6
 troubleshooting
 related diagnostic procedures B-2
 typographical conventions 2

U

Ucast. See Unicast frames
 UNI
 in ATM 12-2
 UNI see User Network Interface
 UNI version
 update 7-9
 UNI/NNI parameters
 configuring 3-7
 unicast
 ATM port 7-2
 unicast frames
 data direct 12-15
 unknown 12-15
 unknown address
 definition 12-13
 unknown unicast flooding mode 12-14, 12-15
 unknown unicast-flooding mode
 update 8-17
 update

admin-access password 10-14
 Bridge ATM address 7-4
 Bridge connection-completion-timer 8-13
 Bridge forward-delay-time 8-11
 Bridge LE-ARP response-time 8-11
 Bridge path-switching-delay 8-12
 Bridge topology-change-flag 8-11
 Bridge-aging-time 6-10
 broadcast threshold 6-6
 control time-out 8-9
 default gateway 9-3
 ELAN name 8-6
 Fast Ethernet port attributes 6-7
 hardware time-out delay 10-11
 IP Address for Bridge 9-2
 LEC aging-time 8-10
 LEC operational parameters 8-9
 LECS address 8-6
 LES ATM address 8-7
 NMS IP address 9-5
 read-access password 10-13
 software time-out delay 10-12
 static address 6-19
 store-and-forward mode 10-7
 STP Bridge-forward-delay 6-25
 STP Bridge-hello-time 6-24
 STP Bridge-path-cost 6-28
 STP Bridge-port attributes 6-27
 STP Bridge-priority 6-24
 subnet mask 9-4
 system configuration mode 10-6
 UNI version 7-9
 unknown unicast-flooding mode 8-17
 VCC time-out period 10-13
 write-access password 10-13
 User Datagram Protocol (UDP) 14-4
 user interfaces 14-1
 User Network Interface, see UNI

V

VCC
 data direct 12-13
 VCC time-out
 LEC 12-17
 VCI
 virtual channel connection 12-3
 Virtual Channel Connection, see VCC
 Virtual Channel Identifier, see VCI
 Virtual LAN
 box-wide 3-2
 configuring 3-8, 3-10, 5-1
 connecting local segments to 12-18
 for Workgroup 12-21
 in 7600 Card 12-18

overview 12-17
Virtual LANS, see vLANS
Virtual Path Connection see VPC
Virtual Path Identifier, see VPI 12-3
virtual terminal protocols 14-1, 14-7
VPC 12-3

Z

ZipChip ASIC
7600 Card 12-11