

Installation and Reference Guide

HP J3175A
HP J3177A



HP AdvanceStack Switch 208/224



HP Customer Support Services

How to get the latest software/agent firmware

You can download from the World Wide Web, HP FTP Library Service, CompuServe, and HP BBS a compressed file (j3178xx.exe) containing the latest version of the HP Switch 208/224 Management Module software and proprietary MIB. After you download the file, **extract** the file by typing *filename* and pressing **[Enter]**. For example, j317801 **[Enter]**.

World Wide Web

http://www.hp.com/go/network_city

Select the “Support” section.

From this web site, you can also download information on the HP networking products. If you have a growing network, download the *Designing HP AdvanceStack Workgroup Networks Guide* or call 1-800-752-0900 in the U.S. to receive a copy through the mail.

HP FTP Library Service

1. FTP to Internet IP Address — ftp ftp.hp.com.
2. Log in as anonymous and press **[Return]** at the password prompt.
3. Enter bin to set the transfer type.
4. Enter cd /pub/networking/software.
5. Enter get *filename* to transfer the file to your computer, then quit.

CompuServe

1. Login to CompuServe.
2. Go to the “hp” service.
3. Select “HP Systems, Disks, Tapes, etc.”
4. Select “Networking Products” library.
5. Download *filename* and then quit.

HP BBS

Set your modem to no parity, eight bits, 1 stop bit, set speed up to 14400 bps, and with your telecommunication program (e.g., Windows Terminal) dial (208) 344-1691 in the U.S. to get the latest software for your HP networking product. For other countries, see <http://www.hp.com/cposupport/eschome.html>.

(over for more services)



Obtain the latest console code (j3178xx.exe) from:

HP FTP Library: ftp ftp-boi.external.hp.com

World Wide Web: http://www.hp.com/go/network_city

HP BBS: (208) 344-1691

(over)



HP FIRST Fax Retrieval Service

HP FIRST is an automated fax retrieval service that is available 24 hours a day, seven days a week. HP FIRST provides information on the following topics:

- Product information
- Troubleshooting instructions
- Technical reviews and articles
- Configuration information

To access HP FIRST, dial one of the following phone numbers:

Location	Phone Number
U.S. and Canada Only	Dial 1 (800) 333-1917 with your fax machine or touch-tone phone and press 1.
Outside the U.S. and Canada	Dial 1 (208) 344-4809 from your fax machine and press 9.

To receive a list of currently available documents, enter document number 19941. The information you requested will be sent to you by return fax. For other countries, see <http://www.hp.com/cposupport/eschome.html>.

Additional HP Support Services

In addition to the above services, you can purchase various HP telephone support services which provide you expert HP technical assistance:

- Network Phone-In Support provides you support at an hourly rate. In the U.S., call 1-800-790-5544. In other countries, please contact your local HP Response Center to see if this service is available in your country.
- HP SupportPack Comprehensive Network Support provides complete problem resolution for medium to large interconnected local and wide area networks. Contact your HP Authorized Reseller or the nearest HP Sales and Support Office for more information.

HP offers other hardware support services. Please contact your reseller for more information.



CompuServe: Go hpsys
 Lib 7.
 Download j3178xx.exe

Network Phone-In
Support (hourly): 1-800-790-5544

HP AdvanceStack Switch 208/224

Installation and Reference Guide

© Copyright 1997 Hewlett-Packard Company
All Rights Reserved.

This document contains information which is protected by copyright. Reproduction, adaptation, or translation without prior permission is prohibited, except as allowed under the copyright laws.

Publication Number

5966-5225
Edition 1
March 1997

Applicable Products

HP J3175A AdvanceStack Switch 208T
HP J3177A AdvanceStack Switch 224T

Disclaimer

The information contained in this document is subject to change without notice.

HEWLETT-PACKARD COMPANY MAKES NO WARRANTY OF ANY KIND WITH REGARD TO THIS MATERIAL, INCLUDING, BUT NOT LIMITED TO, THE IMPLIED WARRANTIES OF MERCHANTABILITY AND FITNESS FOR A PARTICULAR PURPOSE. Hewlett-Packard shall not be liable for errors contained herein or for incidental or consequential damages in connection with the furnishing, performance, or use of this material.

Hewlett-Packard assumes no responsibility for the use or reliability of its software on equipment that is not furnished by Hewlett-Packard.

Warranty

A copy of the specific warranty terms applicable to your Hewlett-Packard products and replacement parts can be obtained from your HP Sales and Service Office or authorized dealer.

Contents

1 Installing the Switch 208/224

<u>Included Parts</u>	1-2
<u>Installation Steps</u>	1-2
1. <u>Prepare the Installation Site</u>	1-3
2. <u>Install Any Optional Modules</u>	1-4
3. <u>Verify the Switch's Operation</u>	1-6
4. <u>Mount the Switch</u>	1-8
5. <u>Connect the Switch to a Power Source</u>	1-12
6. <u>Connect the Network Cables</u>	1-13
<u>Sample Network Topologies</u>	1-15
<u>As a Segment Switch</u>	1-15
<u>As a Desktop Switch</u>	1-16
<u>Connecting to a Backbone Switch</u>	1-17
<u>Cable Management</u>	1-18
<u>Where to Go From Here</u>	1-18

2 Switch 208/224 Description

<u>Features</u>	2-1
<u>Front of the Switches</u>	2-2
<u>Network Ports</u>	2-2
<u>LEDs</u>	2-3
<u>Management Slot</u>	2-4
<u>Back of the Switches</u>	2-5
<u>Power Connectors</u>	2-5
<u>Redundant Power Supply (RPS) Connector</u>	2-5
<u>Expansion Slot</u>	2-5
<u>Switch Operation</u>	2-6
<u>Address Table Operation</u>	2-6
<u>Simultaneous Network Communications</u>	2-7

3 Troubleshooting

<u>Solutions to Common Problems</u>	3-1
<u>LED Error Indications</u>	3-3
<u>Diagnostic Tests</u>	3-4
<u>Testing the Switch</u>	3-4
<u>Testing Twisted-Pair Cabling</u>	3-4
<u>Testing End-to-End Network Communications</u>	3-5
<u>Testing Switch-to-Device Network Communications</u>	3-5
<u>Resetting the Switch</u>	3-6
<u>HP Customer Support Services</u>	3-6

A Cables and Connectors

<u>Twisted-Pair Cable/Connector Pin-Outs</u>	A-1
<u>Twisted-Pair Cable for Switch (MDI-X) to Computer (MDI) Network Connection</u>	A-2
<u>Twisted-Pair Cable for Switch (MDI-X) to Hub or Switch (MDI-X) Network Connection</u>	A-3
<u>Twisted-Pair Cable Pin Assignments</u>	A-4
<u>Fiber-Optic Cables</u>	A-4

B Specifications

C Safety and Regulatory Statements

<u>Mounting Precautions</u>	C-1
<u>Power Precautions</u>	C-2
<u>Safety Information</u>	C-3
<u>Safety Information (Japanese)</u>	C-8
<u>Regulatory Statements</u>	C-9
<u>Declaration of Conformity</u>	C-10

Index

Installing the Switch 208/224

The HP AdvanceStack Switch 208T and 224T are low-latency, high-speed switches that you can use to build high-performance switched workgroup networks.

The two switch models are:

HP J3175A AdvanceStack Switch 208T

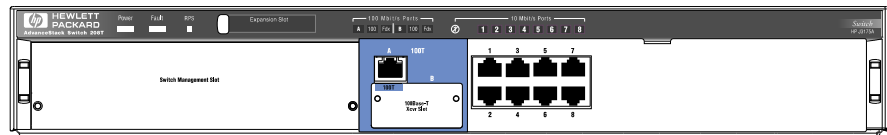

HP J3177A AdvanceStack Switch 224T

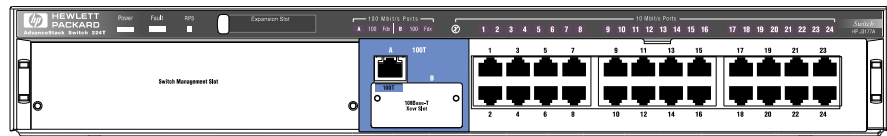

Throughout this manual, these switches will be abbreviated as the Switch 208T and Switch 224T, or, when common characteristics are being described, as the Switch 208/224.

The Switch 208T and 224T have eight and twenty-four 10Base-T ports, respectively, and two 100Base-T ports: one fixed RJ-45 port and one transceiver slot for installing an HP 100Base-TX or 100Base-FX Transceiver Module.

With these switches you can build a switched network infrastructure by connecting hubs or other switches, or you can connect computers, printers, and servers to these switches to provide dedicated bandwidth to those devices.

This chapter shows you how to install your Switch 208T or 224T.

Included Parts

The Switch 208T and 224T have the following components shipped with them:

- *HP AdvanceStack Switch 208/224 Installation and Reference Guide* (5964-5225), this manual
- Warranty booklet
- Accessory kit (5063-8570)
 - two mounting brackets
 - two cable ties
 - four 10 mm M3 thread-forming screws to attach the mounting brackets to the switch
 - four 5/8-inch number 12-24 screws to attach the switch to a rack
- Power cord, one of the following:

Australia/New Zealand/China	(8120-6810)
Denmark	(8120-6814)
Europe	(8120-6811)
Japan	(8120-6798)
Switzerland	(8120-6815)
United Kingdom	(8120-6809)
United States/Canada	(8120-6812)

Installation Steps

Follow these easy steps to install your switch. The rest of this chapter provides details on these steps.

1. Prepare the installation site
2. Install any optional modules
3. Verify that the switch passes self test
4. Mount the switch
5. Connect power to the switch
6. Connect the network cables

1. Prepare the Installation Site

- **Cabling Infrastructure** - Ensure that the cabling infrastructure meets the necessary network specifications:
 - For the 10Base-T ports, use category 3, 4, or 5, four-pair, 100 ohm UTP (unshielded twisted-pair) cables. Cable lengths can be up to 100 meters for category 3 or 4, and 150 meters for category 5. For connecting these ports to end nodes, use “straight-through” cable; for connecting to hubs or other switches, use “crossover” cable. See appendix A, “Cables and Connectors” for more information
 - For the fixed 100Base-TX port and 100Base-TX transceivers that you install in the transceiver slot, use category 5, 100-ohm UTP cables. Cable lengths can be up to 100 meters.

For connecting these ports to end nodes, use “straight-through” cable; for connecting to hubs and switches, use “crossover” cable.
 - For 100Base-FX transceivers that you install in the transceiver slot, use 1300 nm multi-mode fiber-optic cables that are fitted with SC connectors, and conform to ISO/IEC 793-2 type B1 and ITU-T G.652 standards. Cable lengths can be up to 1 kilometer.
- **Installation Precautions** -
 - Before installing the switch, plan its location and orientation relative to other devices and equipment. In the front of the switch, leave at least 3 inches (7.6 cm) of space for the twisted-pair and fiber-optic cabling. In the back, leave at least 1 1/2 inches (3.8 cm) of space for the power cord.
 - **Caution:** Ensure that the switch does not overload the power circuits, wiring, and over-current protection. To determine the possibility of overloading the supply circuits, add together the ampere ratings of all devices installed on the same circuit as the switch and compare the total with the rating limit for the circuit. The maximum ampere ratings are usually printed on the devices near the AC power connectors.
 - **Caution:** *Ensure that the power source circuits are properly grounded.* See the Safety Statements at the end of this manual.
 - Do not install the switch in an environment where the operating ambient temperature might exceed 55°C (131°F).
 - Make sure the air flow around the sides of the switch is not restricted.

2. Install Any Optional Modules

Install optional modules into the Management Slot, Expansion Slot, or transceiver slot by following the instructions in the manuals that accompany these products.

Each of the slot covers can be removed with either a flat-bladed or Torx T-10 screwdriver. Retain the slot covers for future use.

Caution

To avoid damage to circuitry in the switch and any modules, always unplug the power from the switch before installing a module into the Expansion Slot, Management Slot, or transceiver slot, and when removing any modules.

If you do not install an optional module, make sure that the cover plate is still attached over the slot for safe operation and proper switch cooling.

Installing Modules

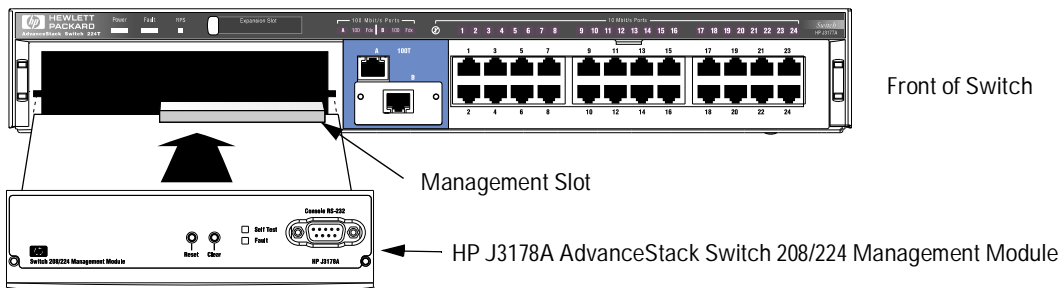

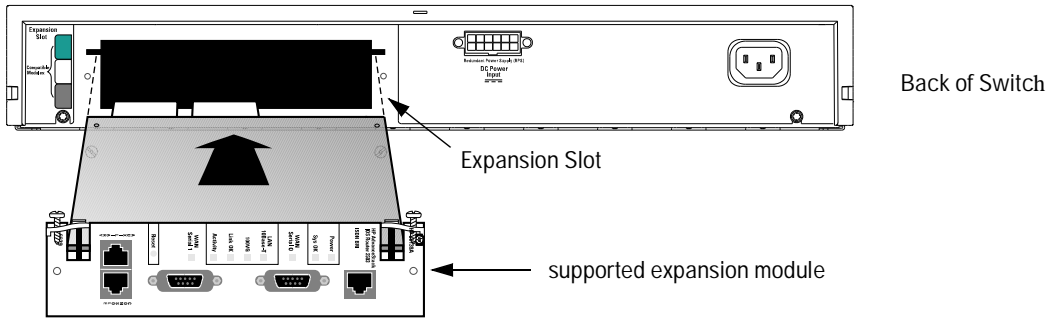

Note

An expansion slot module uses the switch port 1 circuitry to communicate with the other switch ports. Therefore, installing an expansion module disables port 1 as reflected by the LED  on the front of the switch.

Installing Transceivers

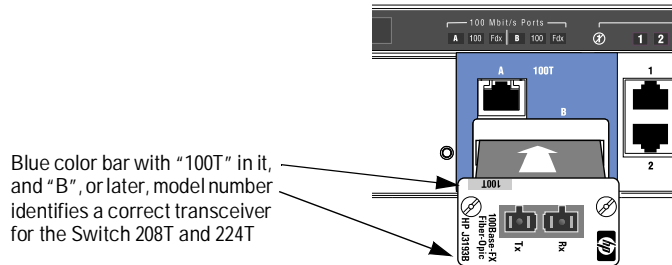

Install either of these HP 100Base-T transceiver modules into the transceiver slot:

- HP J3192**B** 100Base-TX Twisted-Pair Transceiver Module
- HP J3193**B** 100Base-FX Fiber-Optic Transceiver Module

Cautions

Make sure you install only the "B" model or later versions of these 100Base-T transceiver modules into the Switch 208/224.

Do not install any 100VG transceiver modules in this slot.

3. Verify the Switch's Operation

After you have installed any modules, but before mounting the switch in its network location, you should first verify that it is working properly by plugging it into a power source and verifying that it passes its self test.

1. Connect the power cord supplied with the switch to the power connector on the back of the switch, and then into a properly grounded electrical outlet.

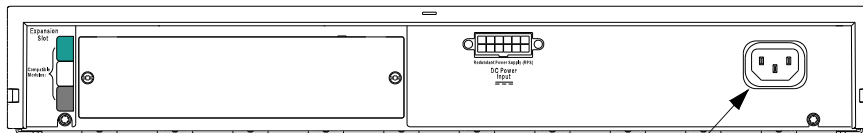

Connect power cord to power connector.

Note

The Switch 208/224 does not have a power switch. It is powered on when the power cord is connected to the switch and to a power source.

If your installation requires a different power cord than the one supplied with the switch, be sure to use a power cord displaying the mark of the safety agency that defines the regulations for power cords in your country. The mark is your assurance that the power cord can be used safely with the switch.

2. Check the LEDs on the switch's front panel (and on the Switch Management Module, if one is installed in the switch). The LED behavior is described on the next page.

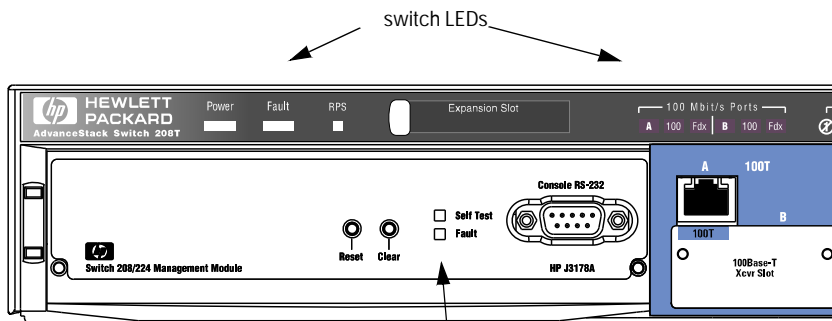

Switch Management Module LEDs

When the switch is powered on, it performs its diagnostic self test. With the Switch Management Module installed, the self test takes approximately 15 seconds to complete. Without the Switch Management Module, the test completes in approximately 4 seconds.

LED Behavior:

During the self test:

- Initially, all LEDs are on.
- With a Management Module installed, the switch port LEDs all go off after approximately 10 seconds, and the Management Module Self Test and Fault LEDs stay on for an additional 5 to 7 seconds.

When the self test completes successfully:

- The Power LED and, if an RPS is connected, the RPS LED remain on. The “100” LED for port A also stays on.
- The Fault LED on the switch, and the Self Test and Fault LEDs on the Management Module go off.
- The port LEDs go into their normal operational mode, if they are connected to active network devices.

If the LED display is different than what is described above, especially if any Fault LEDs stay on for more than 30 seconds or flash, the self test has not completed correctly. Refer to chapter 3, “Troubleshooting” for diagnostic help.

4. Mount the Switch

After the modules are inserted and you have verified that the switch passes self test, you are ready to mount the switch in a stable location. The Switch 208/224 can be mounted in three ways:

- in a rack or cabinet
- on a wall
- on a horizontal surface

Mounting the Switch in a Rack or Cabinet

The Switch 208/224 is designed to be mounted in any EIA-standard 19-inch telco equipment rack. To order a rack for your switch, call HP at 1-800-538-8787 to order product number HP 46298D.

For safe operation, please read the mounting precautions in appendix C, “Safety and Regulatory” before mounting a switch.

1. Use a #1 Phillips (cross-head) or Pozidriv screwdriver and attach the mounting brackets to the switch with the included 10-mm M3 thread-forming screws.

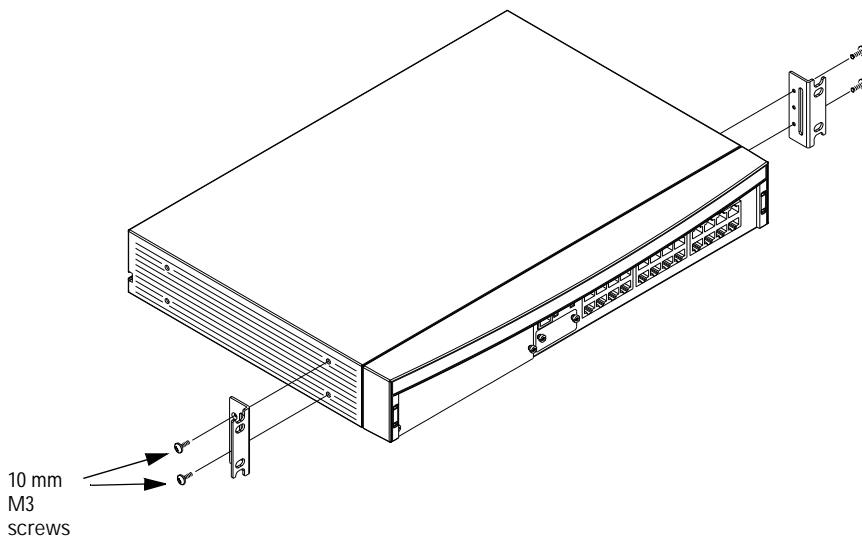

- 2. Partially install a screw (5/8-inch number 12-24) into the top hole of a pair of holes that are 0.5 inches apart in each rack/cabinet upright as shown in the illustration below. Tighten each screw enough to support the weight of the switch, approximately two turns. Ensure that the screws are at the same level in each upright.

Insert a screw into the top hole of a pair close (0.5-inch)

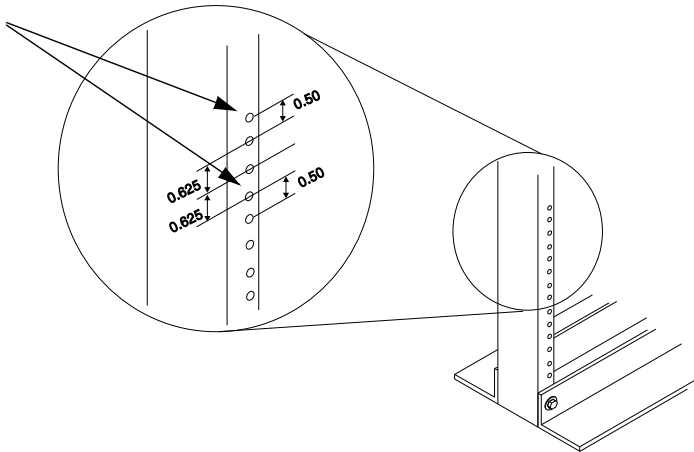

- 3. Place the switch in the rack and lower it so the notches in the bottom of the bracket slide onto the screws. Tighten these screws-*be careful not to overtighten.*

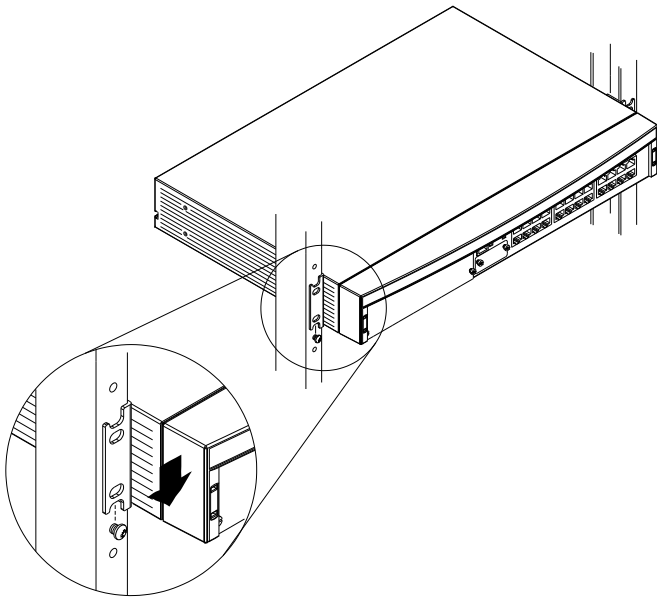

4. Install the other number 12-24 screw into the upper hole in each bracket. Tighten these screws *be careful not to overtighten*.

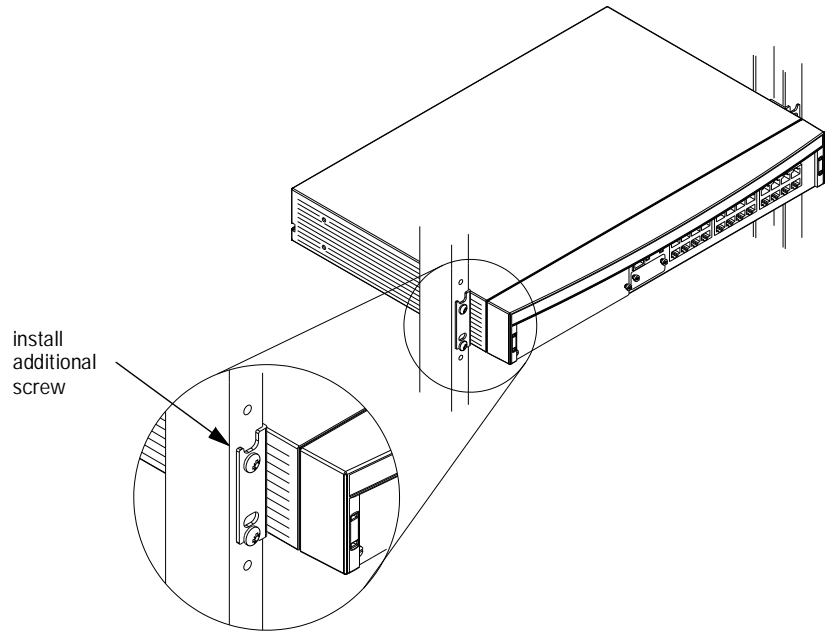

Mounting the Switch on a Wall

You can mount the switch on a wall as shown in the illustration below. Note that the switch should be mounted only to a wall or wood surface that is at least 1/2-inch plywood or its equivalent.

1. Using a Phillips (cross-head) or Pozidriv screwdriver with the 10-mm M3 thread-forming screws included in the accessory kit, attach the mounting brackets to the switch as shown in the illustration below.
2. Attach the switch to the wall or wood surface with 5/8-inch number 12 wood screws (not included).

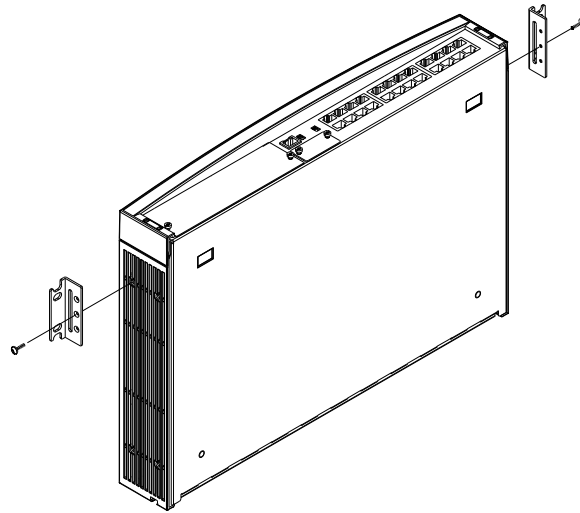

Mounting the Switch on a Horizontal Surface

Place the switch on a table or other horizontal surface. Use a sturdy surface in an uncluttered area. You may want to secure the networking cables and switch power cord to the table leg or other part of the surface structure to help prevent people from tripping over the cords.

Caution

Make sure the air flow is not restricted around the sides and back of the switch, and around the HP J2692A Redundant Power Supply, if used.

5. Connect the Switch to a Power Source

1. *(Optional.)* This product supports use of the HP J2962A Redundant Power Supply (RPS), which can help ensure continuous switch operation in the event of a power failure. If you have this HP RPS, connect the RPS to the switch now and connect the RPS to an appropriate AC power source.

Caution

When installed, the RPS is used in place of the standard power cord, so make sure you disconnect the standard power cord from the switch before you connect the RPS. Using both the standard power cord and the RPS at the same time could damage the switch's components.

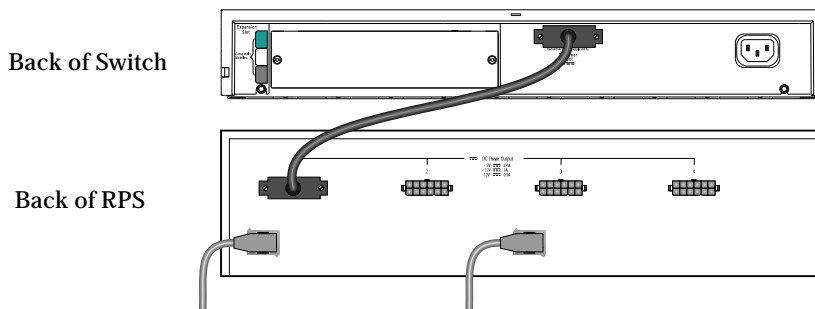

For information on how to install and connect the HP RPS, refer to the documentation supplied with the RPS.

2. If you are not using an RPS, plug the included power cord into the switch's power cord receptacle and into an AC power source as shown below.

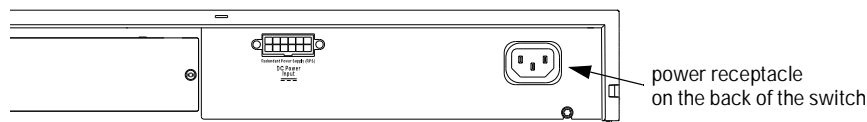

3. Re-check the LEDs during self test. Initially, all LEDs are on. After the four-second self test (or 15 second self test with Management Module), only the Power and port A "100" LEDs (and optionally the RPS LED) are on. See "LED Behavior" on page 7.

6. Connect the Network Cables

Using RJ-45 Connectors (10 Mbit/s and 100 Mbit/s ports)

To connect:

Push the RJ-45 plug into the RJ-45 jack until the tab on the plug clicks into place.

When power is on for the switch and the connected device, the Port LED should light to confirm a powered-on device (for example, an end node) is at the other end of the cable.

To disconnect:

Press the small tab on the plug and pull the plug out of the jack.

Caution:

Do not connect a 10 Mbit/s network into either of the 100 Mbit/s ports.

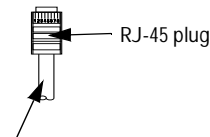
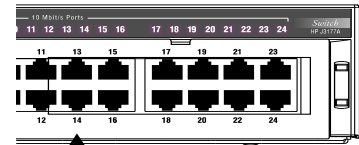

Unshielded twisted-pair cable:

Category 3, 4, or 5 for 10 Mbit/s ports

Category 5 only for 100 Mbit/s ports

Cat 3, 4 maximum distance: 100 meters

Cat 5 maximum distance: 150 meters for 10BT
100 meters for 100BT

100Base-T Xcvr Slot

An optional 100Base-T transceiver module can be installed in the switch's transceiver (Xcvr) slot to provide additional connectivity choices, including:

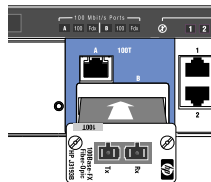

HP 100Base-FX Fiber-Optic Transceiver Module
(HP J3193B)

Maximum Distance: 1 kilometer

HP 100Base-TX Twisted-Pair Transceiver Module
(HP J3192B)

Category 5 maximum distance: 100 meters

See the documentation accompanying the optional transceiver modules for cabling configurations for those modules.

If the Port LED does *not* go on when the network cable is connected to the port, use this table to solve the problem:

Condition	Diagnostic Tip
Port LED is still off when a cable is connected	<p data-bbox="651 340 815 366">Try the following:</p> <ul data-bbox="651 373 1259 895" style="list-style-type: none"><li data-bbox="651 373 1259 427">• For the indicated port, verify that both ends of the cabling, switch and connected device, are snug.<li data-bbox="651 430 1259 484">• Verify the connected device and switch are both powered <i>on</i> and operating correctly.<li data-bbox="651 487 1259 618">• Verify that you have used the correct cable type for the connection. For twisted-pair cable connections, in general, for connecting to an end node, use “straight-through” cable; for connecting to hubs or other switches, use “crossover” cable.<li data-bbox="651 621 1259 675">• Verify that you have not connected a 10 Mbit/s network cable into one of the 100 Mbit/s ports.<li data-bbox="651 678 1259 861">• Verify that if you are connecting the cable to port 1, the switch does not have an optional expansion module installed in the expansion slot in the back of the switch. When an expansion module is installed, it uses the port 1 circuitry to communicate with the rest of the network through the switch and the port 1 RJ-45 connector is thus disabled.<li data-bbox="651 864 1259 895">• Use a different port or a different cable. <p data-bbox="651 925 1259 1029">If you have installed the Switch Management Module, you can use the console interface or HP AdvanceStack Assistant network management software to determine the state of the port and re-enable the port if necessary.</p>

Sample Network Topologies

This section shows you a few sample network topologies in which the Switch 208/224 is implemented. See the document *Designing HP AdvanceStack Workgroup Networks*, which can be found on the HP network products World Wide Web site, http://www.hp.com/go/network_city, and on the CD-ROM supplied with the Switch Management Module. You may also be able to obtain a printed copy of this document from your HP-authorized LAN dealer.

As a Segment Switch

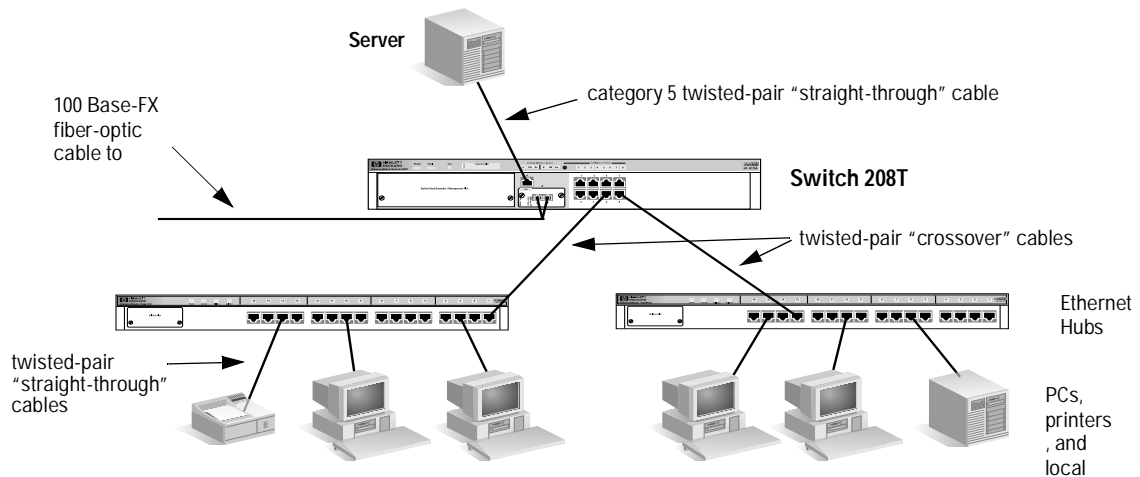

In general, the Switch 208T is designed to be used as a segment switch. That it, with its large address table (8000 MAC addresses) and high performance, it is ideal for interconnecting network segments -- simply connect the network hubs that form those segments to the Switch.

In the illustration above, two Ethernet hubs with PCs, printers, and local servers attached, are both connected to a Switch 208T. The devices attached to the two hubs can now communicate with each other through the switch. They can also all communicate with the server that is connected to the switch through its 100Base-TX port. Connecting the server to the 100 Mbit/s port allows a large number of users to access the server without causing network congestion.

The switch, in turn, is connected to a network backbone through fiber-optic cabling connected to a 100Base-FX transceiver installed in the switch. Now, all the devices in this network can access other network resources that are connected elsewhere on the network backbone.

As a Desktop Switch

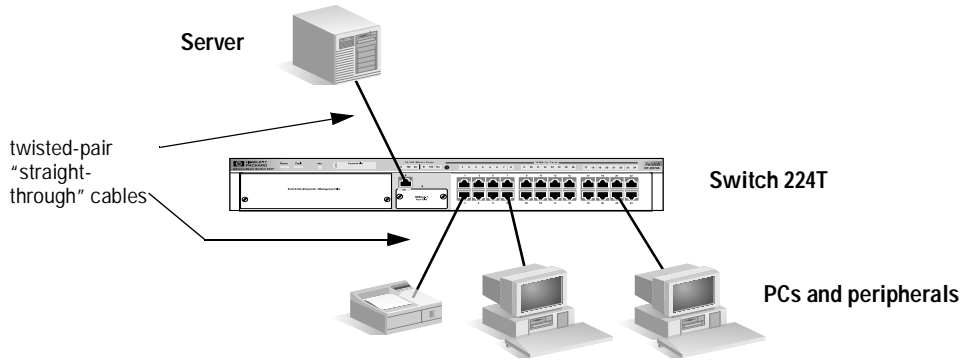

Switch 224T is designed to be used as a desktop switch to which end nodes, printers and other peripherals, and servers are directly connected. Although, since it has the same large 8000 address table and high performance as the Switch 208T, it also can be used as a segment switch. Or, you could, of course, connect a combination of end nodes and hubs to the Switch 224T ports.

Connecting to a Backbone Switch

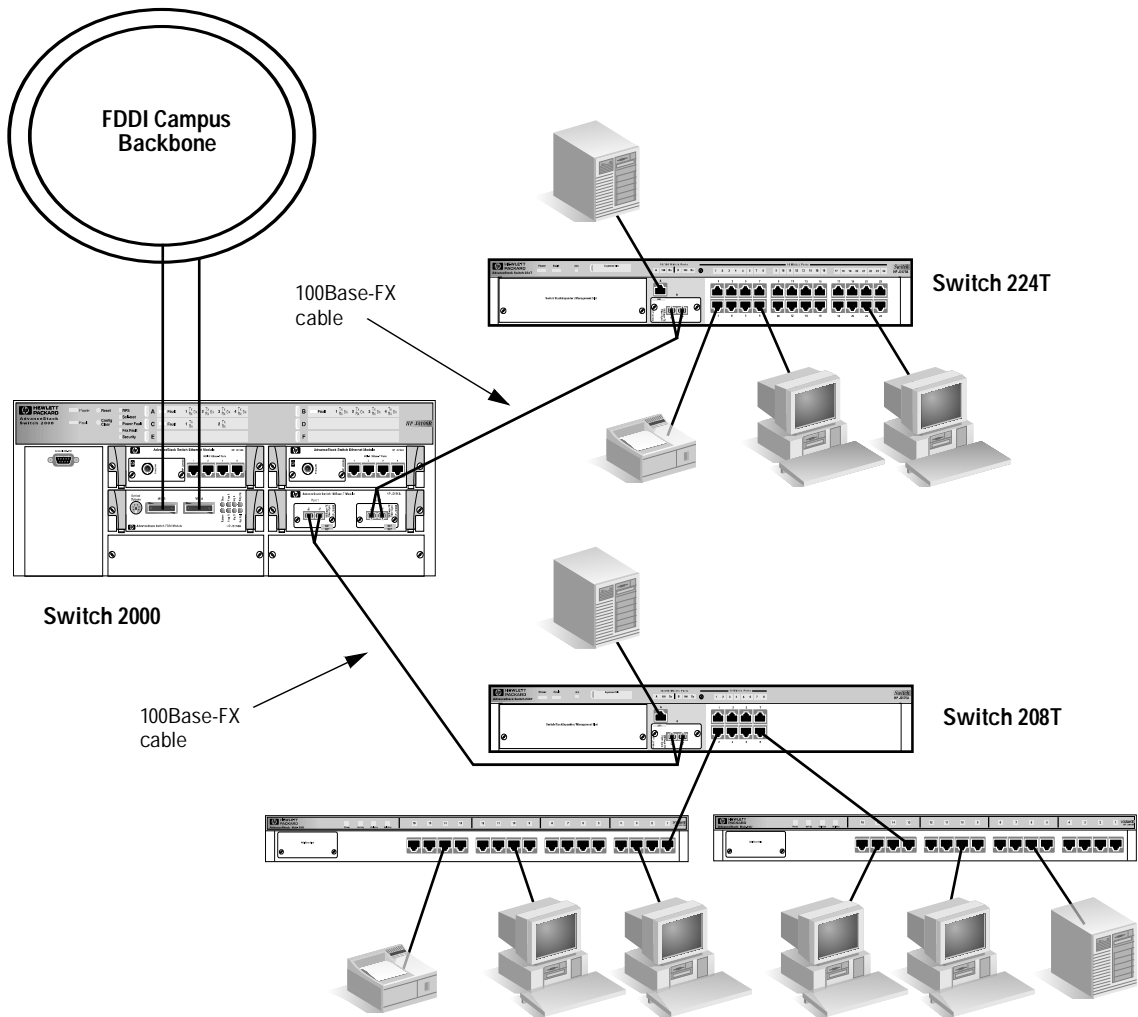

The simpler segment and desktop networks shown in the previous two examples can easily be combined and expanded. For example, you could use an HP Switch 2000 to interconnect each of your smaller switched workgroups to form a larger switched network. All the devices in this network can communicate with each other. With an FDDI Module, for example, in the Switch 2000, the entire switched topology could be connected to a campus backbone, as shown in the illustration above.

Cable Management

The Switch 208/224 has been designed to help you with the problem of managing your network cables. On both sides of the front of each switch are two holes that accept a cable tie to tie-wrap your cables. Simply slide the end of the cable tie into the top or bottom hole until it appears out the other hole as shown in the illustration below. Then use the cable tie to bundle the network cables together

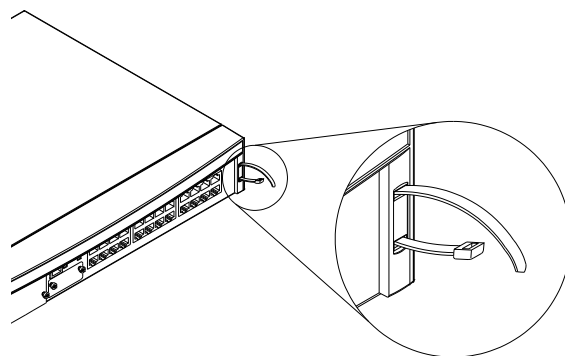

Where to Go From Here

Your switch is now correctly installed and is able to send and receive data between end nodes, servers, and printers.

The Switch 208/224 are plug-and-communicate network devices requiring no configuration. If you wish to manage the switch from an SNMP-based network management station, you will need to install an HP Switch 208/224 Management Module in the switch. If the management is over an IP network, you will also need to configure the IP address on the switch; see the *HP Switch 208/224 Management Module Installation and Reference Guide* for information on how to use the switch console interface or HP AdvanceStack Assistant to configure the IP address. For Novell Netware (IPX) networks, no configuration is necessary to manage the switch--the network address is automatically generated.

Switch 208/224 Description

The HP AdvanceStack Switch 208T and 224T are high-speed, multiport switches that can be used to build switched networks with both Ethernet/IEEE 802.3 and 100Base-T devices, including computers, servers, and printers, as well as other network infrastructure devices: hubs, bridges, other switches, and routers.

This chapter describes your HP AdvanceStack Switch 208T and 224T including:

- Features
 - Front and back of the switches
 - Switch operation
-

Features

The features of the Switch 208T and 224T include:

- All ports are enabled -- just connect the network cables to active network devices and your switched network is operational.
- Network addresses are automatically learned and stored in the switches 8000-address forwarding table.
- All network ports (fixed and transceiver) operate in half-duplex mode at the speed indicated on the switch labeling, either 10 Mbit/s or 100 Mbit/s.

Front of the Switches

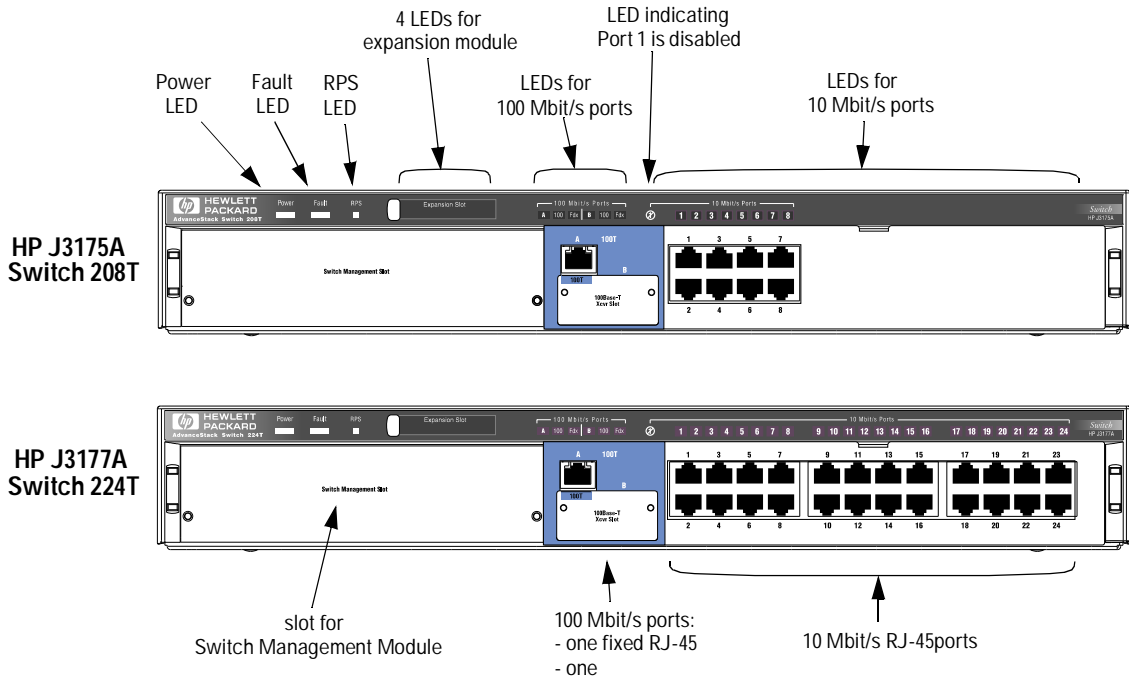

Network Ports

- 8 or 24 10 Mbit/s RJ-45 Ethernet/IEEE 802.3 ports
- one fixed 100 Mbit/s RJ-45 100Base-TX port
- one 100 Mbit/s transceiver slot for installing HP 100Base-TX or 100Base-FX transceivers

All the twisted-pair ports are wired as MDI-X. Therefore, to connect end nodes or other MDI-type devices to these ports, use “straight-through” twisted-pair cable; to connect hubs, switches, or other MDI-X-type devices to these ports, use “crossover” twisted-pair cable. See appendix A, “Cables and Connectors” for descriptions of these cables.

The cabling to the transceiver port depends on the type of transceiver installed. For more information, refer to the manual that came with the transceiver.

LEDs

LED	State	Meaning
Power (green)	Off	The switch is not receiving power.
	On	The switch is receiving power.
Fault	On	The switch has failed its self-test after being powered on or reset.
	Flashing Slowly*	An incorrect transceiver has been installed in the transceiver slot, or a connected RPS has a failure. The corresponding LED (transceiver port or RPS) will also flash.
	Off	The normal state. Indicates that there are no fault conditions on the switch.
RPS	Off	This switch is not receiving power from the HP J2962A Redundant Power Supply (RPS).
	On	This switch is receiving power from the connected RPS.
	Flashing Slowly*	An error has occurred on the RPS connected to the switch. See the documentation provided with the RPS for troubleshooting.
Expansion Slot Module LEDs (4)		The behavior of these four LEDs depends on the module inserted into the Expansion Slot. See the module manual for a description of these LEDs.
 (port 1 disabled)	On	Indicates that an optional module is installed in the expansion slot in the back of the switch. Any expansion modules installed into the switch use the port 1 circuitry to communicate with the network through the switch. Therefore, when a module is installed, the port 1 RJ-45 connector is can not be used to connect a network device.
	Off	The port 1 RJ-45 connector is available to be used for connecting a network device to the switch.
100 Mbit/s Ports		
A or B	Off	No active network cable is connected to the port. For port B, could indicate that there is no transceiver installed. Could also indicate that the port has been disabled through the switch console or HP AdvanceStack Assistant (port configuration changes require a Switch Management Module to be installed).
	On	During the first 3 seconds after an active network cable is connected or after a switch reset, indicates the port is enabled and receiving a link beat signal. After 3 seconds, On continuously indicates a saturated network segment on the port.
	Flickering	Indicates activity on the port.
	Flashing Slowly*	This condition will only occur on the 100 Mbit/s port B (the transceiver port), if an incorrect transceiver is installed in the slot.
100	On	The port is operating in 100 Mbit/s mode.
Fdx	On	The port is operating in full-duplex mode.
	Off	The port is operating is half-duplex mode, or is not operating.

LED	State	Meaning
10 Mbit/s Ports		
Port Number	Off	The port is not receiving the link beat signal from the attached node or the port is disabled.
	On	The port is enabled and link beat is detected from the attached node.
	Flickering	Indicates activity on the port.
* The slow flash behavior is a regular pulse once every 1.6 seconds, approximately.		

Management Slot

The Management Slot in the front of the switch allows you to install an HP Switch 208/224 Management Module. When installed, the Switch Management Module adds these features to your switch:

Management Module Features

- Access to the switch console from which you can configure, monitor, and troubleshoot the switch
- Access to the switch from SNMP network management programs, such as HP AdvanceStack Assistant, for controlling the switch using an advanced, graphics-based interface
- Configurable full-duplex port operation
- Configurable support for the Spanning Tree Protocol for switched networks
- Configurable MAC Address Table aging

For more information on the HP Switch 208/224 Management Module, contact your HP-authorized LAN reseller, or you can find out about HP switches and their accessories, and other HP networking products by visiting the World Wide Web site http://www.hp.com/go/network_city.

Back of the Switches

Power Connectors

The switch does not have a power switch; it is powered on when it is connected to either an active AC power source, using the AC power connector, or an active HP RPS, using the RPS power connector. Using the AC power connector, the switch automatically adjusts to any voltage between 100-127 and 200-240 volts and either 50 or 60 Hz. There are no voltage range settings required.

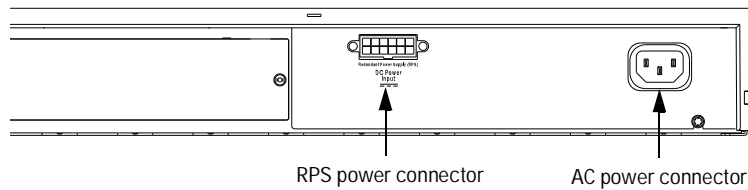

Redundant Power Supply (RPS) Connector

The RPS connector allows you to connect this switch to the HP J2962A Redundant Power Supply. A single RPS shares the load with up to 4 switches. The RPS has redundant power supplies to keep the switch up and running; it is used in place of the switch's standard power cable (NOT in addition to it).

Expansion Slot

The Expansion Slot is used to add connectivity/functionality through modules such as the HP J3138A AdvanceStack Internet Router Module to the switch. Other modules may be available. Contact your HP-authorized dealer or reseller for more information.

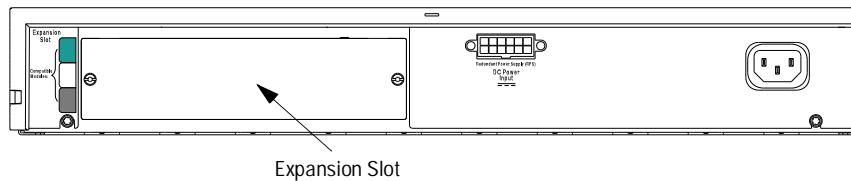

Expansion slot modules have a colored extractor handles that match a color bar on the switch. Before inserting a module, verify that the color matches.

Switch Operation

Address Table Operation

Address Learning. As devices are connected to the switch ports, either directly or through hubs or other switches that are connect to the switch, the MAC addresses of those devices are learned automatically and stored in the Switch 208/224's 8000-entry address table. The switch also identifies the number of the port on which each address is learned so it knows the network location of each device.

Forwarding, Filtering, Flooding. When the switch receives a packet, it determines the destination address, looks for the address in the address table. Based on the port location of that address, the switch then determines whether to forward, filter-out, or flood the packet.

- **forward** - if the destination address is on a different port than the one on which the packet was received, the packet is forwarded to the destination port and on to the destination device.
- **filter out** - if the destination address is on the same port as the one on which the packet was received, the packet is filtered out. The switch thereby isolates local traffic so the rest of the network connected to the switch does not lose bandwidth dealing with unnecessary traffic.
- **flood** - whenever a new destination address is found in a packet, the destination address will not yet be in the switch's address table and the Switch 208/224 cannot know whether to forward or filter out the packet. In this case, it sends the packet to all the ports. This is referred to as "flooding". When the destination device receives the packet, it replies, and the switch learns the new address from the reply packet. Then, all future packets destined for that address are forwarded or filtered out appropriately.

Network Moves and Changes. When devices are moved in the network, and become connected to a different switch port, the Switch 208/224 automatically recognizes the change and updates the address table with the new port location of the device. Communication with the device is automatically maintained, without any address table manipulation being required.

Simultaneous Network Communications

In addition to traffic isolation benefits provided by the Switch 208/224 address table operation, the switch also enhances network performance because it can conduct multiple, simultaneous network connections. In the case of the Switch 224T, with its 26 ports, it can have up to 13 separate network connections going simultaneously. Instead of sharing the network bandwidth, as in connections to a hub, each connection has its own 10 Mbit/s or 100 Mbit/s bandwidth to use.

Troubleshooting

This chapter describes how to troubleshoot your Switch 208/224. Note that if you have a Switch 208/224 Management Module, you can troubleshoot your switch using software. See the *HP AdvanceStack Switch 208/224 Management Module Installation and Reference Guide* for more information.

This chapter describes the following:

- solutions to common problems
 - LED error indications
 - diagnostic tests
 - resetting the switch
 - HP Customer Support Services
-

Solutions to Common Problems

Most problems are caused by the following situations:

- **Incorrect switch-to-switch or switch-to-hub connections.** If you have connected your switch to another switch or a hub by using twisted-pair cable from an RJ-45 MDI-X connector on your switch to the same type of connector on the other switch or hub, you must use a crossover cable. If you have used a straight-through cable, the connection will not work. The LED for the port you are using will not come on when you connect the cable.

Use crossover twisted-pair cable for switch-to-switch or switch-to-hub connections, and straight-through cable for switch-to-end node connections. See appendix A, “Cables and Connectors” for pinouts and correct cable wiring for crossover and straight-through twisted-pair cables.

- **Faulty cable or cable is loose.** Look for loose or obviously faulty connections. If they appear to be OK, try a different cable.
 - **Non-standard cables.** Non-standard and miswired cables may cause numerous network collisions, and can seriously impair network performance. Use a new correctly-wired cable or compare your cable to the
-

cable in appendix A, “Cables and Connectors” for pinouts and correct cable wiring. A category 5 cable tester is a recommended tool for every 100Base-T network installation.

- **Improper Network Topologies.** It is important to make sure you have a valid network topology. Common topology faults include excessive cable length and excessive repeater delays between nodes. If you have network problems after recent changes to the network, change back to the previous topology. If you no longer experience the problems, the new topology is probably at fault. Refer to the guide entitled *Designing HP AdvanceStack Workgroup Networks* for topology configuration guidelines. This guide is included on the HP AdvanceStack Products CD-ROM that comes with the HP Switch 208/224 Management Module. The guide can also be found online at the HP World Wide Web site, http://www.hp.com/go/network_city.

In addition, you should make sure that your network topology contains no data path loops. Between any two end nodes, there should be only one active cabling path at any time. Data path loops will cause broadcast storms that will severely impact your network performance. If you wish to build redundant paths between important nodes in your network to provide some fault tolerance, you should install a Switch 208/224 Management Module and enable Spanning Tree Protocol support on the switch. This ensures that only one of the redundant paths is active at any time, thus avoiding data path loops.

- **Switch 208/224-Specific Connectivity Situations:**

For the Switch 208T and 224T, there are a few specific network connection situations you must avoid:

- **Wrong transceiver type** -- You have installed an HP 100VG transceiver into the transceiver slot. The slot is specifically designed to be used with the HP 100Base-T transceivers. *Make sure that you install only “B” model or later 100Base-T transceivers in this slot, for example HP J3192B.*
- **Wrong network speed connected** -- You have connected a 10 Mbit/s cable to one of the 100 Mbit/s ports. On the Switch 208/224, the 100 Mbit/s ports cannot operate at 10 Mbit/s.
- **Expansion Module installed** -- When you install an optional expansion module in the back of the switch, it uses the port 1 circuitry to communicate to the rest of the network through the switch. In this case, the port 1 RJ-45 connector (and only that connector) becomes disabled, as shown by the port 1 disabled LED on the front of the switch .

LED Error Indications

LED patterns indicating problems				Diagnostic Tips
Power	Fault	RPS	Port	
OFF	*	*	*	Check the power cord and power source. If they are OK, the switch may have to be replaced. Contact your HP-authorized LAN dealer or HP representative for assistance.
ON	OFF	*	OFF when cable first connected	<p>Link beat has not been detected on the port. Check that the cabling on the indicated port is connected properly. Faulty or improperly wired cables are common; try a different cable.</p> <p>For the 100 Mbit/s ports, verify that you are using category 5, or better, UTP or the appropriate fiber-optic cable. Also, the you have not connected a 10 Mbit/s device to the port.</p> <p>If you have a Management Module in the switch, use HP AdvanceStack Assistant or the switch console to determine the state of the port: - Determine if the port was disabled. Re-enable if desired.</p>
ON	Flashing	*	Flashing	This could only occur with the port LED for the 100 Mbit/s transceiver port, and only when a 100VG transceiver module has been installed in the slot. Only 100Base-TX and 100Base-FX transceivers should be installed in the transceiver slot.
ON	Flashing	Flashing	*	The Redundant Power Supply (RPS) has experienced a fault and is now using its backup power capabilities. See the documentation provided with the RPS for troubleshooting.
OFF	*	OFF and you are using an RPS	*	The switch is not receiving power from the Redundant Power Supply (RPS). If you have an RPS connected, check the status of the RPS and check the cable and power connections on both the switch and the RPS.
ON	Flashing	*	Variable	A fault has been detected during self test in a switch component that controls network communications through multiple switch ports. Try power cycling the switch. If the error persists, the switch may have to be replaced. Contact your HP-authorized LAN dealer or HP representative for assistance.
ON	ON for a prolonged period	*	Variable, all may be ON	<p>A switch hardware failure was detected during self-test. Self-test does not complete so the LEDs will stay on longer than 60 seconds.</p> <p>Power cycle the switch. If this condition persists, the switch may have to be replaced. Contact your HP-authorized LAN dealer or HP representative for assistance.</p>
<p>* This LED is not important for the diagnosis. The flashing behavior is a regular pulse once every 1.6 seconds, approximately.</p>				

Diagnostic Tests

When a Management Module is installed, the HP AdvanceStack Assistant and switch console software provide tests, indicators, and an event log that can be used to monitor the switch and its network connections. See chapter 7, “Troubleshooting”, in the *HP AdvanceStack Switch 208/224 Management Module Installation and Reference Guide* for more information.

Testing the Switch

If you believe that the switch is not operating correctly, you can reset the switch to test its circuitry. To reset a switch, either:

- Remove and reinsert the power cord for the switch.
- Press the Reset button on the optional Switch Management Module (if installed).

Testing Twisted-Pair Cabling

If you think the cable should work but still isn't working, it may not be compatible with the IEEE 802.3 Type 10Base-T or 100Base-T standards. The twisted-pair cables attached to the Switch 208/224 must be compatible with these standards. To verify that your cable is compatible with these standards, use a qualified cable test device.

HP also offers a wire testing service. Contact your HP-authorized LAN dealer or your local HP sales office for more information.

Note

Make sure that you are using the correct cabling type for each connection. The switch UTP ports are all wired as MDI-X. For connecting end nodes and other MDI-type devices, use “straight-through” cable. For connecting hubs, other switches, and other MDI-X devices, use “crossover” cable. See appendix A, “Cables and Connectors” for the pinouts for these cables.

Also, make sure that you have not inadvertently connected a 10 Mbit/s device to one of the 100 Mbit/s ports, or a 100 Mbit/s device to one of the 10 Mbit/s ports.

Testing End-to-End Network Communications

Both the switch and the cabling can be tested by running an end-to-end communications test -- a test that sends known data from one network device to another through the switch. For example, if you have two PCs on the network that have HP LAN adapters, you can use the “Link Test” option from the adapter’s test program (for example, HPLANSet) to verify that the entire communication path between the two PCs is functioning correctly. See your LAN adapter documentation for more information on running the Link Test.

Note

Link Test can be performed from end node to end node through the switch even if the switch does not have a Switch Management Module installed. But, with the module, the switch itself cannot respond to any network connectivity tests (link test, Ping test, or IPX Ping test).

Testing Switch-to-Device Network Communications

If you have a Switch Management Module installed in the switch, you can perform the following communication tests to verify that the network is operating correctly between the switch and any connected device that can respond correctly to the communication test.

- Link Test -- a physical layer test that sends IEEE 802.2 test packets to any device identified by its MAC address
- Ping Test -- a network layer test used on IP networks that sends test packets to any device identified by its IP address
- IPX Ping Test -- a network layer test used on IPX networks that sends test packets to any device identified by its IPX address

These tests can be performed through the switch console interface from a terminal connected to the Switch Management Module. See the *HP AdvanceStack Switch 208/224 Management Module Installation and Reference Guide* for more information.

These tests can also be performed from an SNMP network management station running a program that can manage the switch, for example, HP AdvanceStack Assistant.

Resetting the Switch

You can reset the switch by unplugging and plugging back in the power cord; each switch does not have a reset button. By reinserting the power cord, the switch performs the power-on self-test. No configuration is changed.

HP Customer Support Services

If you are still having trouble with your switch, Hewlett-Packard offers support 24 hours a day, seven days a week through the use of automated electronic services including:

- the World Wide Web
- HP BBS
- HP FTP Library Service on the Internet
- CompuServe
- HP Network Phone-In Support (NPS)
- HP FIRST FAX Retrieval Service

See the perforated card at the beginning of this manual for information on how to use these services to get technical support.

Your HP-authorized network reseller can also provide you with assistance, both with services that they offer and with services offered by HP.

Cables and Connectors

This appendix lists cables that have been tested and verified for use with the HP Switch 208/224. It also includes minimum pin-out information so, if you wish to use an unlisted cable, you can verify that the cables used in your installation are correctly wired. Note that each pin-out does not necessarily match the pin-out for the corresponding HP cable, but cables manufactured to follow the minimum pin-out will function correctly.

Note

Incorrectly wired cabling is the most common cause of problems for LAN communications. HP recommends that you work with a qualified LAN cable installer for assistance with your cabling requirements.

Twisted-Pair Cable/Connector Pin-Outs

The RJ-45 ports (10 Mbit/s and 100 Mbit/s, both fixed and transceiver) on the Switch 208/224 are wired as MDI-X ports. The type of twisted-pair cable you connect to these ports (either “straight through” or “crossover”) depends on the type of device at the other end of the cable.

The basic rule is, when connecting same-type ports together (for example MDI-X-to-MDI-X), use crossover cable; when connecting opposite-type ports together (for example MDI-X-to-MDI), use straight-through cable.

These additional rules apply:

- All twisted-pair wires used must be twisted through the entire length of the cable. The wiring sequence must conform to AT&T 258A (not USOC). See “Twisted-Pair Cable Pin Assignments” later in this appendix for a listing of the signals used on each pin.
- For connections to the 10 Mbit/s ports, you can use Category 3, 4, or 5 unshielded twisted-pair cable, as supported by the IEEE 802.3 Type 10Base-T standard.
- For connections to the 100 Mbit/s ports, use Category 5 only, as supported by the IEEE 802.3u Type 100Base-TX standard.

Twisted-Pair Cable for Switch (MDI-X) to Computer (MDI) Network Connection

To connect PCs or other MDI network devices to these ports, use a “straight-through” cable.

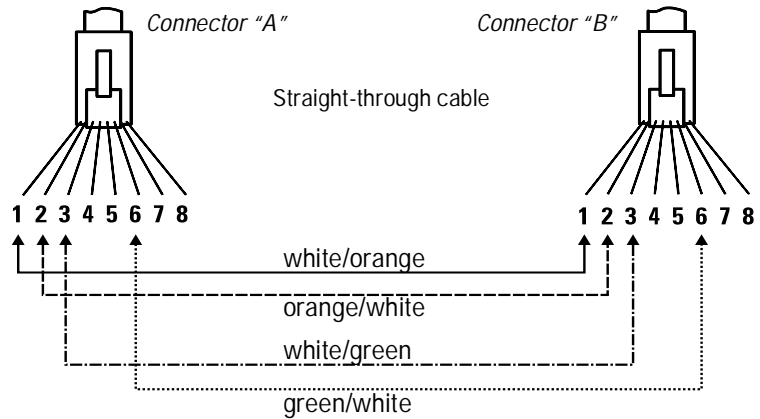

Note

Pins 1 and 2 on connector “A” *must* be wired as a twisted pair to pins 1 and 2 on connector “B”.

Pins 3 and 6 on connector “A” *must* be wired as a twisted pair to pins 3 and 6 on connector “B”.

Pins 4, 5, 7, and 8 are not used in this application, although they may be wired in the cable.

Twisted-Pair Cable for Switch (MDI-X) to Hub or Switch (MDI-X) Network Connection

To connect hubs or switches or other MDI-X network devices to these ports, use a “crossover” cable.

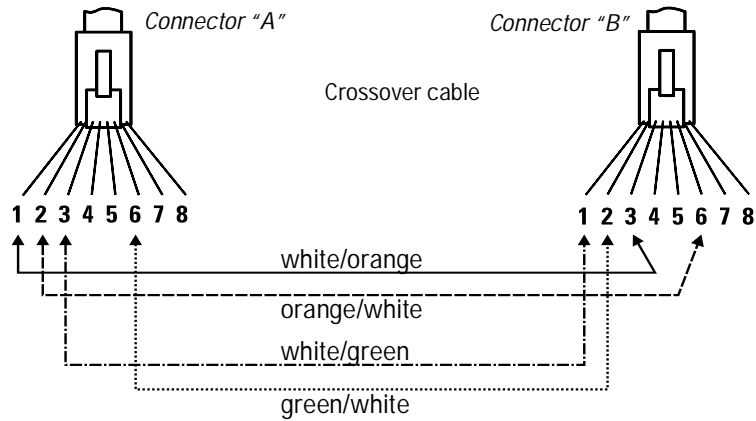

Note

Pins 1 and 2 on connector “A” *must* be wired as a twisted pair to pins 3 and 6 on connector “B”.

Pins 3 and 6 on connector “A” *must* be wired as a twisted pair to pins 1 and 2 on connector “B”.

Pins 4, 5, 7, and 8 are not used in this application, although they may be wired in the cable.

Twisted-Pair Cable Pin Assignments

Twisted-Pair Straight-Through Cable

Switch End (MDI-X)		Computer, Transceiver, or Other MDI Port End	
Signal	Pins	Pins	Signal
(receive +)	1	1	(transmit +)
(receive -)	2	2	(transmit -)
(transmit +)	3	3	(receive +)
(transmit -)	6	6	(receive -)

Twisted-Pair Cross-Over Cable

Switch End (MDI-X)		Hub or Switch Port, or Other MDI-X Port End	
Signal	Pins	Pins	Signal
(receive +)	1	6	(transmit -)
(receive -)	2	3	(transmit +)
(transmit +)	3	2	(receive -)
(transmit -)	6	1	(receive +)

Fiber-Optic Cables

Fiber-optic cables connected to an HP fiber-optic transceiver installed in the switch's transceiver slot must be 1300 nm wavelength, multimode cable conforming to the ISO/IEC 793-2 type B1, and ITU-T G.652 standards. To connect to the HP 100Base-FX Fiber-Optic Transceiver Module, the cables must have SC-type connectors.

Specifications

Physical

Width:	44.2 cm (17.4 in)
Depth:	29.8 cm (11.7 in)
Height:	6.6 cm
Weight:	
Switch 208T	4.4 kg (9.71 lb)
Switch 224T	4.5 kg (9.95 lb)

Electrical

The HP Switch 208T and 224T automatically adjust to any voltage between 100-127 and 200-240 volts and either 50 or 60 Hz.)

AC voltage:	100-127 volts	200-240 volts
Maximum current:	1.4 A	0.8 A
Frequency range:	50/60 Hz	50/60 Hz

Environmental

	Operating	Non-Operating
Temperature:	+0°C to +55°C (32°F to 131°F)	-40°C to 70°C (-40°F to 158°F)
Relative humidity: (non-condensing)	15% to 95% at 40°C (104°F)	15% to 90% at 65°C (149°F)
Maximum altitude:	4.6 km (15,000 ft)	4.6 km (15,000 ft)

Connectors

- The 10 Mbit/s RJ-45 twisted-pair ports are compatible with the IEEE 802.3 Type 10Base-T standard.
- The 100 Mbit/s RJ-45 twisted-pair port is compatible with the IEEE 802.3u standard.

Electromagnetic

Verified to:
FCC part 15 Class A
CISPR22 / EN55022 Class A
VCCI Class 1

Immunity

EN50082-1

See the Declaration of Conformity for additional information at the end of appendix C, "Safety and Regulatory Statements".

Safety

Complies with

IEC 950: (1991)+A1,A2/.EN60950 I(1992)+A1,A2

UL1950

CSA 950

NOM-019-SCFI-1994

Acoustic Noise

Geraeuschemission $L_{wA}=53$ dB am fiktiven Arbeitsplatz nach DIN 45635 T.19

Safety and Regulatory Statements

This chapter covers the following topics:

- mounting precautions
 - power precautions
 - safety and regulatory statements
 - Declaration of Conformity
-

Mounting Precautions

When you put a switch into a rack, follow these mounting precautions:

- The rack or cabinet should be adequately secured to prevent it from becoming unstable and/or falling over. The first switch (or single switch) should be mounted in a position toward the bottom of the rack for stability and to make it easier to stack the other switches on top.
 - Before mounting a switch, plan its location and orientation relative to other devices and equipment. Also consider the cabling that will be attached to the switch and the ports that will be used. Verify that there is room for the grouped cables to trail out from the side of the switch. Allow at least 7.6 cm (3 inches) in the front of the switch. In the back of the switch, allow at least 3.8 cm (1 1/2 inches) of space for the power cord.
 - Ensure that the switch does not overload the power circuits, wiring, and over-current protection. To determine the possibility of overloading the supply circuits, add together the amperage ratings from all your switches (and other equipment) installed on the same circuits and compare the total with the rating limits for the supply circuits.
 - Make sure that the power source circuits are properly grounded, then use the supplied power cord to connect the switch to the circuit. *See the Safety Statements in this chapter.*
 - Do not install the switch in an environment where the operating ambient temperature might exceed 55°C (131°F).
 - Make sure the air flow around the sides of the switch is not restricted.
-

Power Precautions

Follow these precautions when unplugging and plugging in power to the switch as well as adding or removing modules.

Caution

Before installing an optional module into the Expansion Slot, Management Slot, or transceiver slot, unplug the switch. Damage to the switch or module could occur if you attempt to install the module without unplugging the switch. If you do not install an optional module, verify that the cover plates are covering the slot. A cover plate is required not only for safe operation, but also to ensure proper switch cooling.

Caution

If your installation requires a different power cord than the one supplied with the switch, be sure to use a power cord displaying the mark of the safety agency that defines the regulations for power cords in your country. The mark is your assurance that the power cord can be used safely with the switch.

Note

The switch does not have a power switch; it is powered on when the power cord is plugged in. The switch's power supply automatically adjusts to any AC power source between 100-127 volts and 200-240 volts. There are no voltage range settings to configure.

When installing the switch, note that the AC outlet must be installed near the equipment and should be easily accessible.

Safety Information



Documentation reference symbol. If the product is marked with this symbol, refer to the product documentation to get more information about the product.

WARNING

A WARNING in the manual denotes a hazard that can cause injury or death.

CAUTION

A CAUTION in the manual denotes a hazard that can damage equipment.

Do not proceed beyond a WARNING or CAUTION notice until you have understood the hazardous conditions and have taken appropriate steps.

Grounding

These are safety class I products and have protective earthing terminals. There must be an uninterruptible safety earth ground from the main power source to the product's input wiring terminals, power cord, or supplied power cord set. Whenever it is likely that the protection has been impaired, disconnect the power cord until the ground has been restored.

For LAN cable grounding:

- If your LAN covers an area served by more than one power distribution system, be sure their safety grounds are securely interconnected.
- LAN cables may occasionally be subject to hazardous transient voltages (such as lightning or disturbances in the electrical utilities power grid). Handle exposed metal components of the network with caution.

Servicing

There are no user-serviceable parts inside these products. Any servicing, adjustment, maintenance, or repair must be performed only by service-trained personnel.

These products do not have a power switch; they are powered on when the power cord is plugged in.

Informations concernant la sécurité



Symbole de référence à la documentation. Si le produit est marqué de ce symbole, reportez-vous à la documentation du produit afin d'obtenir des informations plus détaillées.

WARNING

Dans la documentation, un WARNING indique un danger susceptible d'entraîner des dommages corporels ou la mort.

CAUTION

Un texte de mise en garde intitulé CAUTION indique un danger susceptible de causer des dommages à l'équipement.

Ne continuez pas au-delà d'une rubrique WARNING ou CAUTION avant d'avoir bien compris les conditions présentant un danger et pris les mesures appropriées.

Cet appareil est un produit de classe I et possède une borne de mise à la terre. La source d'alimentation principale doit être munie d'une prise de terre de sécurité installée aux bornes du câblage d'entrée, sur le cordon d'alimentation ou le cordon de raccordement fourni avec le produit. Lorsque cette protection semble avoir été endommagée, débrancher le cordon d'alimentation jusqu'à ce que la mise à la terre ait été réparée.

Mise à la terre du câble de réseau local:

- si votre réseau local s'étend sur une zone desservie par plus d'un système de distribution de puissance, assurez-vous que les prises de terre de sécurité soient convenablement interconnectées.
- Les câbles de réseaux locaux peuvent occasionnellement être soumis à des surtensions transitoires dangereuses (telles que la foudre ou des perturbations dans le réseau d'alimentation public). Manipulez les composants métalliques du réseau avec précautions.

Aucune pièce contenue à l'intérieur de ce produit ne peut être réparée par l'utilisateur. Tout dépannage, réglage, entretien ou réparation devra être confié exclusivement à un personnel qualifié.

Cet appareil ne comporte pas de commutateur principal ; la mise sous tension est effectuée par branchement du cordon d'alimentation.

Hinweise zur Sicherheit



Symbol für Dokumentationsverweis. Wenn das Produkt mit diesem Symbol markiert ist, schlagen Sie bitte in der Produktdokumentation nach, um mehr Informationen über das Produkt zu erhalten.

WARNING

Symbol für Dokumentationsverweis. Wenn das Produkt mit diesem Symbol markiert ist, schlagen Sie bitte in der Produktdokumentation nach, um mehr Informationen über das Produkt zu erhalten.

CAUTION

Symbol für Dokumentationsverweis. Wenn das Produkt mit diesem Symbol markiert ist, schlagen Sie bitte in der Produktdokumentation nach, um mehr Informationen über das Produkt zu erhalten.

Fahren Sie nach dem Hinweis WARNING oder CAUTION erst fort, nachdem Sie den Gefahrenzustand verstanden und die entsprechenden Maßnahmen ergriffen haben.

Dies ist ein Gerät der Sicherheitsklasse I und verfügt über einen schützenden Erdungsterminal. Der Betrieb des Geräts erfordert eine ununterbrochene Sicherheitserdung von der Hauptstromquelle zu den Geräteingabeterminals, den Netzkabeln oder dem mit Strom belieferten Netzkabelsatz voraus. Sobald Grund zur Annahme besteht, daß der Schutz beeinträchtigt worden ist, das Netzkabel aus der Wandsteckdose herausziehen, bis die Erdung wiederhergestellt ist.

Für LAN-Kabelerdung:

- Wenn Ihr LAN ein Gebiet umfaßt, das von mehr als einem Stromverteilungssystem beliefert wird, müssen Sie sich vergewissern, daß die Sicherheitserdungen fest untereinander verbunden sind.
- LAN-Kabel können gelegentlich gefährlichen Übergangsspannungen ausgesetzt werden (beispielsweise durch Blitz oder Störungen in dem Starkstromnetz des Elektrizitätswerks). Bei der Handhabung exponierter Metallbestandteile des Netzwerkes Vorsicht walten lassen.

Dieses Gerät enthält innen keine durch den Benutzer zu wartenden Teile. Wartungs-, Anpassungs-, Instandhaltungs- oder Reparaturarbeiten dürfen nur von geschultem Bedienungspersonal durchgeführt werden.

Dieses Gerät hat keinen Netzschalter; es wird beim Anschließen des Netzkabels eingeschaltet.

Considerazioni sulla sicurezza



Simbolo di riferimento alla documentazione. Se il prodotto è contrassegnato da questo simbolo, fare riferimento alla documentazione sul prodotto per ulteriori informazioni su di esso.

WARNING

La dicitura WARNINGdenota un pericolo che può causare lesioni o morte.

CAUTION

La dicituraCAUTION denota un pericolo che può danneggiare le attrezzature.

Non procedere oltre un avviso di WARNING o di CAUTIONprima di aver compreso le condizioni di rischio e aver provveduto alle misure del caso.

Questo prodotto è omologato nella classe di sicurezza I ed ha un terminale protettivo di collegamento a terra. Dev'essere installato un collegamento a terra di sicurezza, non interrompibile che vada dalla fonte d'alimentazione principale ai terminali d'entrata, al cavo d'alimentazione oppure al set cavo d'alimentazione fornito con il prodotto. Ogniqualvolta vi sia probabilità di danneggiamento della protezione, disinserite il cavo d'alimentazione fino a quando il collegaento a terra non sia stato ripristinato.

Per la messa a terra dei cavi LAN:

- se la vostra LAN copre un'area servita da più di un sistema di distribuzione elettrica, accertatevi che i collegamenti a terra di sicurezza siano ben collegati fra loro;
- i cavi LAN possono occasionalmente andare soggetti a pericolose tensioni transitorie (ad esempio, provocate da lampi o disturbi nella griglia d'alimentazione della società elettrica); siate cauti nel toccare parti esposte in metallo della rete.

Nessun componente di questo prodotto può essere riparato dall'utente. Qualsiasi lavoro di riparazione, messa a punto, manutenzione o assistenza va effettuato esclusivamente da personale specializzato.

Questo apparato non possiede un commutatore principale; si mette scotto tensione all'inserirsi il cavo d'alimentazione.

Consideraciones sobre seguridad



Simbolo de referencia a la documentación. Si el producto va marcado con este símbolo, consultar la documentación del producto a fin de obtener mayor información sobre el producto.

WARNING

Una WARNING en la documentación señala un riesgo que podría resultar en lesiones o la muerte.

CAUTION

Una CAUTION en la documentación señala un riesgo que podría resultar en averías al equipo.

No proseguir después de un símbolo de WARNING o CAUTION hasta no haber entendido las condiciones peligrosas y haber tomado las medidas apropiadas.

Este aparato se enmarca dentro de la clase I de seguridad y se encuentra protegido por una borna de puesta a tierra. Es preciso que exista una puesta a tierra continua desde la toma de alimentación eléctrica hasta las bornas de los cables de entrada del aparato, el cable de alimentación o el juego de cable de alimentación suministrado. Si existe la probabilidad de que la protección a tierra haya sufrido desperfectos, desenchufar el cable de alimentación hasta haberse subsanado el problema.

Puesta a tierra del cable de la red local (LAN):

- Si la LAN abarca un área cuyo suministro eléctrico proviene de más de una red de distribución de electricidad, cerciorarse de que las puestas a tierra estén conectadas entre sí de modo seguro.
- Es posible que los cables de la LAN se vean sometidos de vez en cuando a voltajes momentáneos que entrañen peligro (rayos o alteraciones en la red de energía eléctrica). Manejar con precaución los componentes de metal de la LAN que estén al descubierto.

Este aparato no contiene pieza alguna susceptible de reparación por parte del usuario. Todas las reparaciones, ajustes o servicio de mantenimiento debe realizarlos solamente el técnico.

Este producto no tiene interruptor de potencia; se activa cuando se enchufa el cable de alimentación.

Safety Information (Japanese)

安全性の考慮

安全記号



マニュアル参照記号。製品にこの記号がついている場合はマニュアルを参照し、注意事項等をご確認ください。

WARNING マニュアル中の「WARNING」は人身事故の原因となる危険を示します。

CAUTION マニュアル中の「CAUTION」は装置破損の原因となる危険を示します。

「WARNING」や「CAUTION」の項は飛ばさないで必ずお読みください。危険性に関する記載事項をよく読み、正しい手順に従った上で次の事項に進んでください。

これは安全性クラス I の製品で保護用接地端子を備えています。主電源から製品の入力配線端子、電源コード、または添付の電源コード・セットまでの間、切れ目のない安全接地が存在することが必要です。もしこの保護回路が損なわれたことが推測されるときは、接地が修復されるまで電源コードを外しておいてください。

LAN ケーブルの接地に関して:

- もし貴社の LAN が複数の配電システムにより電力を受けている領域をカバーしている場合には、それらのシステムの安全接地が確実に相互に結合されていることを確認してください。
- LAN ケーブルは時として危険な過度電圧（例えば雷や、配電設備の電力網での障害）にさらされることがあります。露出した金属部分の取扱いには十分な注意をはらってください。

本製品の内部にはユーザーが修理できる部品はありません。サービス、調整、保守および修理はサービス訓練を受けた専門家におまかせください。

本製品には電源スイッチがありません。電源コードを接続したとき電源入となります。

Regulatory Statements

FCC Class A Statement (for U.S.A. Only):

This equipment has been tested and found to comply with the limits for a Class A digital device, pursuant to Part 15 of the FCC Rules. These limits are designed to provide reasonable protection against harmful interference when the equipment is operated in a commercial environment. This equipment generates, uses, and can radiate radio frequency energy and, if not installed and used in accordance with the instruction manual, may cause harmful interference to radio communications. Operation of this equipment in a residential area may cause harmful interference in which case the user will be required to correct the interference at his own expense.

VCCI Class 1 (For Japan Only) when using unshielded cables

注意

この装置は、情報処理装置等電波障害自主規制協議会（VCCI）の基準に基づく第一種情報技術装置です。この装置を家庭環境で使用すると電波妨害を引き起こすことがあります。この場合には使用者が適切な対策を講ずるよう要求されることがあります。

European Community

This equipment complies with ISO/IEC Guide 22 and EN55022 Class A with unshielded cables and EN55022 Note

This is a Class A product. In a domestic environment, this product may cause radio interference, in which case the user may be required to take adequate measures.

Canada

This product complies with Class A Canadian EMC requirements.

Declaration of Conformity

The following Declaration of Conformity for the HP AdvanceStack Switch 208T and 224T complies with ISO/IEC Guide 22 and EN 45014. The declaration identifies the product, the manufacturer's name and address, and the applicable specifications that are recognized in the European community.

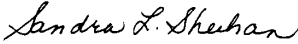
DECLARATION OF CONFORMITY according to ISO/IEC Guide 22 and EN45014	
Manufacturer's Name:	Hewlett-Packard Company
Manufacturer's Address:	8000 Foothills Blvd. Roseville, CA 95747-5502 U.S.A.
declares that the product:	
Product Name:	HP AdvanceStack Switch 208T HP AdvanceStack Switch 224T
Model Number:	HP J3175A HP J3177A
Accessories covered:	HP J3138A, HP J3178A, HP J3192B, HP J3193B, HP J3230A,
conforms to the following Product Specifications:	
Safety:	EN60950 (1992)+A1,A2 / IEC 950:1991+A1,A2
EMC:	EN 55022 (1994) / CISPR-22 (1993) class A EN50082-1 (1992) prEN 55024-2 (1992) / IEC 801-2 (1991) 4 kV CD, 8 kV AD prEN 55024-3 (1991) / IEC 801-3 (1984), 3 V/m prEN 55024-4 (1992) / IEC 801-4 (1988): 1 kV-(power line) 0.5 kV-(signal line)
Supplementary Information:	
The product herewith complies with the requirements of the Low Voltage Directive 73/23/EEC and the EMC Directive 89/336/EEC and carries the CE marking accordingly. LEDs in this product(s) are Class-1 in accordance with EN60825-1:1994.	
Tested with Hewlett-Packard Co. products only.	
Roseville, January 21, 1997	 Sandra L. Sheehan, Quality Manager
European Contact: Your local Hewlett-Packard Sales and Service Office or Hewlett-Packard GmbH, Department TRE, Herrenberger Strasse 130, D-71034 Böblingen (FAX:+49-7031-14-3143).	

Index

Numerics

- 10 Mbit/s ports
 - location on switch ... 2-2
- 100 LED ... 2-3
- 100Base-FX transceiver port
 - cables used with ... 1-3
- 100Base-T ports
 - LEDs for ... 2-3
 - location on switch ... 2-2
- 100Base-T transceivers ... 1-5
- 100Base-TX ports
 - cables used with ... 1-3
- 10Base-T ports
 - LEDs for ... 2-4
 - location on switch ... 2-2

A

- A or B port LED ... 2-3
- address learning ... 2-6
- address table
 - automatic address learning ... 2-6
 - filtering out traffic ... 2-6
 - flooding traffic ... 2-6
 - forwarding traffic ... 2-6
 - moves and changes ... 2-6
 - operation ... 2-6

B

- back of switch
 - description ... 2-5
 - expansion slot ... 2-5
 - power connector ... 2-5
- backbone switch
 - topology with ... 1-17
- bandwidth, how switch enhances ... 2-7

C

- cabinet
 - mounting the switch in ... 1-8
- cable management ... 1-18

cables

- category 3, 4, 5 ... A-1
 - connecting cables to switch ports ... 1-13
 - crossover cable pinout ... A-4
 - fiber-optic ... A-4
 - infrastructure requirements ... 1-3
 - managing ... 2-5
 - straight-through cable pinout ... A-4
 - twisted-pair connector pin-outs ... A-1
- ## crossover cable
- pin-out ... A-4

D

- ## description
- back of switches ... 2-5
 - front of switches ... 2-2
 - switch ... 2-1
- ## desktop switch
- sample topology ... 1-16
- ## diagnostic tests ... 3-4
- end-to-end connectivity ... 3-5
 - testing the switch only ... 3-4
 - testing twisted-pair cabling ... 3-4

E

- ## expansion modules
- effect on switch port 1 ... 1-5, 3-2
 - installation ... 1-5
- ## Expansion Slot
- allowed modules ... 2-5
 - LEDs for ... 2-3

F

- Fault LED ... 1-7, 2-3, 3-3
- Fdx LED ... 2-3
- features
 - Switch 208/224 ... 2-1
 - Switch Management Module ... 2-4
- fiber-optic cables ... A-4
- filtering out traffic ... 2-6

flashing LED
 error indications ... 3-3
flooding traffic ... 2-6
forwarding traffic ... 2-6
front of switch
 description ... 2-2

H

horizontal surface
 mounting switch on ... 1-11
HP Redundant Power Supply (RPS)
 connecting to switch ... 1-12
 connector ... 2-5
 LED ... 2-3
 precautions when using ... 1-12

I

included parts ... 1-2
installing
 optional modules ... 1-4
 Switch 208/224 ... 1-1
 transceivers ... 1-5
IPX ping test ... 3-5

L

LEDs
 10 Mbit/s ports ... 2-4
 100 ... 2-3
 100 Mbit/s ports ... 2-3
 A or B ... 2-3
 descriptions of ... 2-3
 error indications ... 3-3
 Expansion Slot ... 2-3
 Fault ... 2-3
 Fdx ... 2-3
 port 1 disabled ... 1-5, 2-3, 3-2
 Power ... 2-3
 RPS ... 2-3
link test ... 3-5

M

Management Module, Switch
 diagnostics with ... 3-4
 features ... 2-4
 installing ... 1-4
Management Slot
 about ... 2-4
MDI-X to MDI network cable ... A-2
MDI-X to MDI-X network cable ... A-3
mounting precautions ... C-1
mounting the switch
 in a rack ... 1-8
 on a horizontal surface ... 1-11
 on a wall ... 1-11
moves and changes
 effect on address table ... 2-6

N

network ports
 connecting to ... 1-13
 LEDs for ... 2-3
 types of ... 2-2

P

ping test ... 3-5
port 1 disabled LED ... 1-5, 2-3, 3-2
ports
 connecting to ... 1-13
 LEDs for ... 2-3
 types of ... 2-2
power
 connecting switch to ... 1-12
 precautions ... C-2
 using RPS ... 1-12
power connector ... 2-5
Power LED ... 1-7, 2-3, 3-3
precautions
 mounting ... C-1
 power ... C-2

R

rack

- mounting the switch in ... 1-8
- precautions when using ... C-1

resetting the switch ... 3-6

- troubleshooting procedure ... 3-4

RPS (Redundant Power Supply)

- connecting to switch ... 1-12
- LED ... 2-3

S

safety information ... C-1

segment switch

- sample topology ... 1-15

slow flash rate definition ... 2-4

specifications ... B-1

straight-through cable

- pin-out ... A-4

switch

- description ... 2-1
- features ... 2-1
- features added with Switch Management Module ... 2-4
- mounting in a rack or cabinet ... 1-8
- mounting on horizontal surface ... 1-11
- mounting on wall ... 1-11
- operation ... 2-6
- specifications ... B-1

Switch Management Module

- diagnostics with ... 3-4
- features ... 2-4
- installing ... 1-4

switch operation

- description ... 2-6
- verifying after installation ... 1-6

T

testing

- end-to-end communications ... 3-5
- switch-to-device communications ... 3-5
- twisted-pair cabling ... 3-4

topologies

- effects of improper topology ... 3-2
- samples of ... 1-15

transceivers

- installation ... 1-5
- supported types ... 1-5
- when wrong type is used ... 3-2

troubleshooting ... 3-1

- common network problems ... 3-1
- diagnostic tests ... 3-4
- effects of improper topology ... 3-2
- effects of non-standard cables ... 3-1
- switch-specific connectivity situations ... 3-2
- testing the switch ... 3-4
- testing the twisted-pair cables ... 3-4

twisted-pair cable

- crossover cable pin-out ... A-4
- pin-outs ... A-1, A-4
- straight-through cable pin-out ... A-4
- switch-to-computer connection ... A-2
- switch-to-switch or hub connection ... A-3
- testing ... 3-4

twisted-pair port LEDs

- 10 Mbit/s ... 2-4
- 100 Mbit/s ... 2-3

W

wall

- mounting switch on ... 1-11



Technical information in this document is subject to change without notice.

© Copyright 1997
Hewlett-Packard Company
Printed in U.S.A. 3/97

Manual Part Number
5966-5225

