HP AdvanceStack Switching Hubs

Reference Guide

© Copyright 1996 Hewlett-Packard Company
All Rights Reserved.

This document contains information which is protected by copyright. Reproduction, adaptation, or translation without prior permission is prohibited, except as allowed under the copyright laws.

Publication Number

5964-4662
Edition 1
August 1996

Applicable Product

HP J3200A Switching Hub-12R
HP J3202A Switching Hub-24R
HP J3204A Switching Hub-24T
HP J3210A Management Module
HP J3212A Switch Module

Disclaimer

The information contained in this document is subject to change without notice.

HEWLETT-PACKARD COMPANY MAKES NO WARRANTY OF ANY KIND WITH REGARD TO THIS MATERIAL, INCLUDING, BUT NOT LIMITED TO, THE IMPLIED WARRANTIES OF MERCHANTABILITY AND FITNESS FOR A PARTICULAR PURPOSE. Hewlett-Packard shall not be liable for errors contained herein or for incidental or consequential damages in connection with the furnishing, performance, or use of this material.

Hewlett-Packard assumes no responsibility for the use or reliability of its software on equipment that is not furnished by Hewlett-Packard.

Warranty

A copy of the specific warranty terms applicable to your Hewlett-Packard products and replacement parts can be obtained from your HP Sales and Service Office or authorized dealer.

HP Customer Support Services

How to get the latest software/agent firmware

The hub does not have updatable firmware. You can update the following modules:

HP Management Module firmware: j3210a.exe

HP Switch Module firmware: j3212a.exe

from the HP BBS, HP FTP Library Service, CompuServe, and the World Wide Web.

After you download the file, **extract** the file by typing: *filename /x*. For example, *j3210a.exe /x*

HP BBS

Set your modem to no parity, eight bits, 1 stop bit, set speed up to 14400 bps, and with your telecommunication program (e.g., Windows Terminal) dial (208) 344-1691 to get the latest software for your HP networking product.

HP FTP Library Service

1. FTP to Internet IP Address — ftp ftp.hp.com.
2. Log in as anonymous and press at the password prompt.
3. Enter bin to set the transfer type.
4. Enter cd /pub/networking/software.
5. Enter get *filename* to transfer the file to your computer, then quit.

CompuServe

1. Login to CompuServe.
2. Go to the “hp” service.
3. Select “HP Systems, Disks, Tapes, etc.”
4. Select “Networking Products” library.
5. Download *filename* then quit.

World Wide Web

http://www.hp.com/go/network_city

Select the “Support” section.

From this web site you can also download information on the HP Switching Hubs and HP AdvanceStack Assistant. If you have a growing network, download the Designing HP AdvanceStack Workgroup Networks Guide or call 1-800-752-0900 to receive a copy through mail.

(over for more services)



Obtain the latest console code (j3210a.exe) from

HP FTP Library: ftp ftp.hp.com

World Wide Web: http://www.hp.com/go/network_city

HP BBS: (208) 344-1691

(over)



HP FIRST Fax Retrieval Service

HP FIRST is an automated fax retrieval service that is available 24 hours a day, seven days a week. HP FIRST provides information on the following topics:

- Product information
- Troubleshooting instructions
- Technical reviews and articles
- Configuration information

To access HP FIRST, dial one of the following phone numbers:

Location	Phone Number
U.S. and Canada Only	Dial 1 (800) 333-1917 with your fax machine or touch-tone phone and press 1.
Outside the U.S. and Canada	Dial 1 (208) 344-4809 from your fax machine and press 9. To receive a list of currently available documents, enter document number 19941. The information you requested will be sent to you by return fax.

HP Network Phone-In Support (NPS)

In addition to the above services, the HP Network Phone-In Support (NPS) service provides expert technical assistance for U.S.A. customers through an NPS contract or at an hourly rate (1-800-790-5544) Monday through Friday, 5 am to 6 pm, Pacific Time. You may also contact your HP Authorized Reseller or the nearest HP Sales and Support Office to purchase an NPS contract.



CompuServe: Go the "hp" service.
Select HP systems, etc.
Select Networking Products.
Download the file.

Network Phone-In Support (hourly): 1-800-790-5544

Contents

1 Switching Hub Features

<u>Introduction</u>	1-1
<u>Front of the Hub</u>	1-2
<u>LED Operation</u>	1-2
<u>Hub Identification</u>	1-4
<u>Coexistence of Switching Hubs with Other Ethernet Hubs</u>	1-4
<u>Resetting the Hubs</u>	1-4
<u>Extender Cables</u>	1-5
<u>Stack Order</u>	1-6
<u>Back of the Hubs</u>	1-7
<u>Power Connector</u>	1-7
<u>Redundant Power Supply (RPS) Connector</u>	1-7
<u>Expansion Slot</u>	1-7
<u>How the Hub Works</u>	1-8
<u>Collision Detection</u>	1-8
<u>Auto-Partitioning</u>	1-9
<u>Link Beat</u>	1-10

2 Optimizing Your Network

<u>Automatically Segmenting Your Network</u>	2-2
<u>Reasons for Using an Internal vs. External Switch</u>	2-2
<u>HP Internal Switch Module Features</u>	2-3
<u>Managing Your Network with the Management Module</u>	2-4

3 Troubleshooting

<u>Solutions to Common Problems</u>	3-1
<u>LED Error Indications</u>	3-2

<u>Diagnostic Tests</u>	3-3
Testing the Hub or Stack of Hubs	3-3
Testing Twisted-Pair Cabling	3-4
<u>HP Customer Support Services</u>	3-4

A Cables and Connectors

<u>Recommended Cables</u>	A-1
<u>Twisted-Pair Cable/Connector</u>	
<u>Pin-Outs</u>	A-2
Twisted-Pair Cable for Hub-to-Computer	
Network Connection	A-2
Twisted-Pair Cable Pin Assignments	A-3
Twisted-Pair Straight-Through Cable	A-3

B Specifications

C Safety and Regulatory Statements

<u>Mounting Precautions</u>	C-1
<u>Power Precautions</u>	C-2
<u>Safety Information</u>	C-3

Index

Switching Hub Features

Introduction

With the Switching Hubs, you can connect computers, servers, and printers together in an Ethernet network for sharing files. These hubs can coexist with any IEEE 802.3 Type 10Base-T standard hub including HP AdvanceStack and HP EtherTwist products. The three Switching Hub models are:

HP J3200A Switching Hub-12R

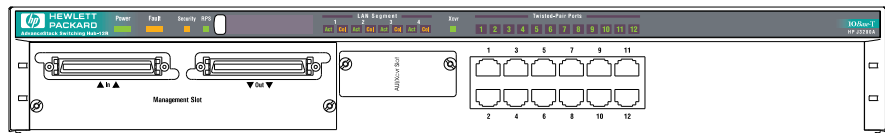

HP J3202A Switching Hub-24R

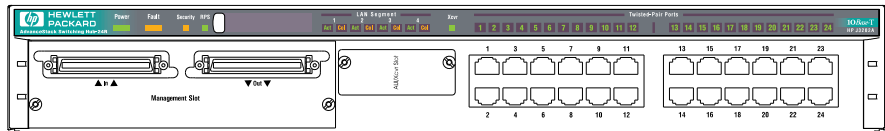

HP J3204A Switching Hub-24T

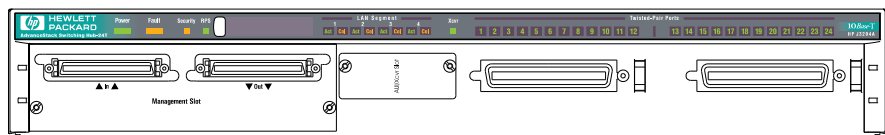

Each hub has four segments or collision domains. By default, all users are put on segment 1. If you add a Management Module, you can distribute the ports over the four segments.

This chapter describes the features of the Switching Hubs.

Front of the Hub

LED Operation

LED	State	Meaning
Power (green)	Off	The hub is not receiving power.
	On	The hub is receiving power.
Fault	On	The hub has failed its self-test after being powered on or reset.
	Flashing Slowly*	A port has partitioned or a connected RPS has a failure. The corresponding LED will also flash.
	Off	The normal state. Indicates that there are no fault conditions on the hub.
Security (<i>only available if a Management Module is installed in the stack</i>)	Flashing Rapidly**	A security violation has occurred on a port. The corresponding port is flashing at the same time for the port violation. Otherwise an SNMP intrusion has occurred on the Management Module. This intrusion may have occurred before the last hub reset. To view security violations or turn off flashing LEDs, use the ASCII console or HP AdvanceStack Assistant as described in the <i>HP Management Module Installation and Reference Guide</i> .
	Off	No security violation detected (the normal state).
RPS	Off	This hub is not receiving power from the HP J2962A Redundant Power Supply (RPS).
	On	This hub is receiving power from the connected RPS.
	Flashing Slowly*	An error has occurred on the RPS connected to the hub. See the documentation provided with the RPS for troubleshooting.
Expansion Slot Module label		The LED behavior depends on the module inserted into the Expansion Slot. See the module manual for a description of these LEDs.

LED	State	Meaning
LAN Segment 1-4 Act (green) Col (orange)	Flickering	Shows the activity and collision status for each segment. Segment 2-4 LEDs flicker if you have moved ports to these segments using an optional Management Module and/or Switch Module. Collision LED: If collisions are infrequent (which is normal) the light may be imperceptible. In a network with heavy traffic, the Col LED will glow and flicker dimly, indicating collisions are occurring. If it appears on continuously (with no flicker), it is a possible indicator of a network fault.
	Flickering	Activity LED: ON while a packet is being transmitted. Normally, the LED appears to flicker. In heavy traffic, it may be on all the time.
Xcvr	Off	There is no transceiver installed or the port has been disabled through the ASCII console or HP AdvanceStack Assistant. (A Management Module is in this stack of hubs.)
	On	The Transceiver module is enabled and not partitioned.
	Flashing Slowly*	The port has been partitioned. The Fault LED will also be flashing at the same rate. See "Partitioning" later in this chapter.
	Flashing Rapidly**	The port has experienced a security violation. The Security LED will also be flashing at the same rate. <i>To turn off flashing LEDs, select Security from the ASCII console or HP AdvanceStack Assistant.</i>
Twisted-Pair Ports	Off	The port is not receiving the link beat signal from the attached node or the port is disabled.
	On	The port is enabled and link beat is detected from the attached node.
	Flashing Slowly*	The port has been partitioned. The Fault LED will also be flashing at the same rate. See "Partitioning" later in this chapter.
	Flashing Rapidly**	The port has experienced a security violation. The Security LED will also be flashing at the same rate. <i>To turn off flashing LEDs, select Security from the ASCII console or HP AdvanceStack Assistant.</i>
<p>* The slow flash rate is approximately once every 1.5 seconds. ** The rapid flash rate is approximately 3 times each second. This condition can exist only if a Management Module is installed in the hub.</p>		

Hub Identification

Below the AUI/Xcvr (Transceiver) port is a label with the Hub Identification number and serial number. The Hub Identification number is displayed in the ASCII console and HP AdvanceStack Assistant to identify the hub in the stack. The format is:

123-1234567

The Hub Identification number is not the MAC address. The Switching Hub does not have a MAC address because it cannot be managed without a Management Module. See the Management Module manual for information on the MAC addresses for a stack.

Coexistence of Switching Hubs with Other Ethernet Hubs

If you have an existing stack of hubs, connect a network cable from one stack to the other as shown on the topology card included with the hubs (5182-9815).

Resetting the Hubs

You can reset the hub by unplugging and plugging back in the power cord; each hub does not have a reset button. By reinserting the power cord, the hub performs the power-on self-test. No configuration is changed.

Extender Cables

The Extender Cable is for communication between users on the same segment across the stack. Use the Extender Cable to connect up to 8 hubs together to make one segment.

As one segment, the connected stack of hubs are considered to be one repeater hop. On initial bootup, all users are placed on segment 1 if no Management Module is present.

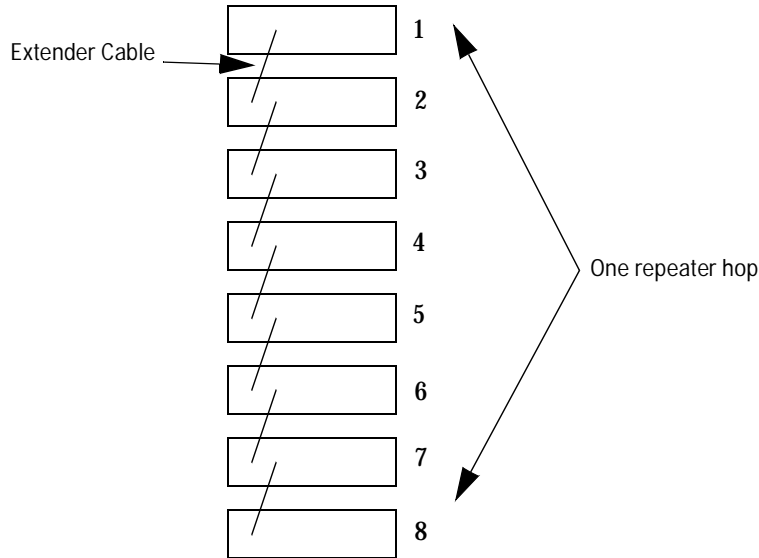

Without the Extender Cable, each Switching Hub has its own collision domain. If you need to manage your stack of hubs, or segment your hubs into different collision domains, see chapter 2, “Optimizing Your Network”.

Stacked hubs can be close together or physically distributed. Each Extender Cable included with a hub is 31.8 cm (12.5 inches). For longer distances, order the Long Extender Cable (71 cm, 28 inch), part number 5182-9869, by calling 1-800-538-8787.

Each stack can have a maximum of two 71 cm (28-inch) cables. Using two 28-inch cables and five 12.5-inch cables, the maximum distance is 2.9 meters (9.9 feet). The following illustration shows a stack of hubs and Long Extender Cable connections that go over an HP Switch 2000 and to a hub in another stack:

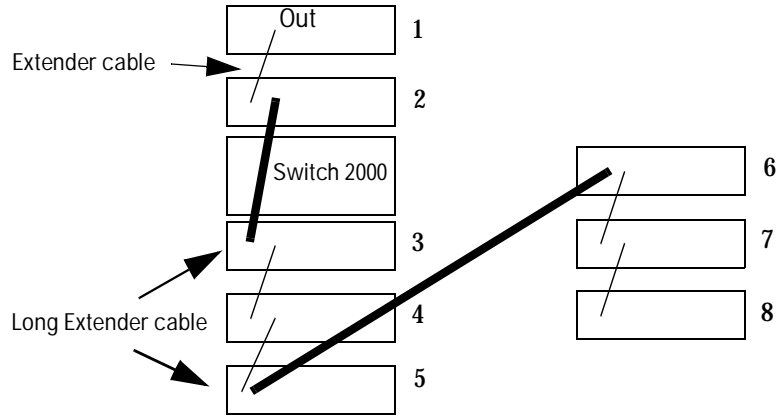

Stack Order

The stack order is determined by which hub has only an Extender Cable connected to the OUT port. Notice that all illustrations in this manual show the top hub with the cable in the OUT port only. By following this topology, the ASCII console and HP AdvanceStack will accurately report which hub is at the top of the stack and number the hubs beneath it in increasing order.

Back of the Hubs

Power Connector

The hub does not have a power switch; it is powered on when the power cord is plugged into the power connector. The Switching Hubs automatically adjusts to any voltage between 100-127 and 200-240 volts and either 50 or 60 Hz. There are no voltage range settings required. If a hub were to fail, all of the other hubs connected to the Extender Cable remain operating because they have separate power cords.

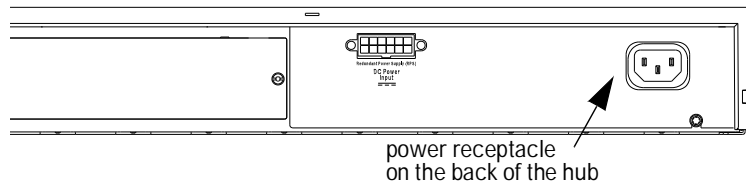

Redundant Power Supply (RPS) Connector

The RPS connector allows you to connect this hub to the HP J2962A Redundant Power Supply. A single RPS shares the load with up to 4 hubs. The RPS has several power supplies to keep the hub up and running.

Expansion Slot

The Expansion Slot is used to add connectivity/functionality through modules such as the HP J3212A AdvanceStack 10BT Switch Module to the stack. Other modules may be available. Contact your HP-authorized dealer or reseller for more information.

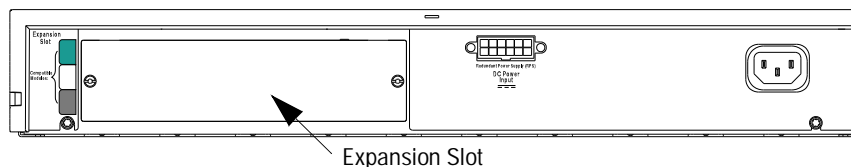

Expansion slot modules have a color on them that match a color bar on the hub. Before inserting a module, verify that the color matches. The Switch Module features are described in chapter 2, "Optimizing Your Network".

How the Hub Works

The HP AdvanceStack Switching Hubs are multiport repeaters that conform to the IEEE 802.3 repeater specification. Data signals coming into the hub from any of its ports are automatically regenerated and transmitted to all the other network ports on the *same* segment in the hub stack. The hub regenerates the data without interpreting the contents, so it can be used in either IEEE 802.3 or Ethernet networks and with any upper-level protocol.

The following illustration shows communication when there is no Management Module in the stack.

Example: John is connected to port 11 and transmits data out of his PC. Data is repeated out of all ports in this stack because they are all on segment 1.

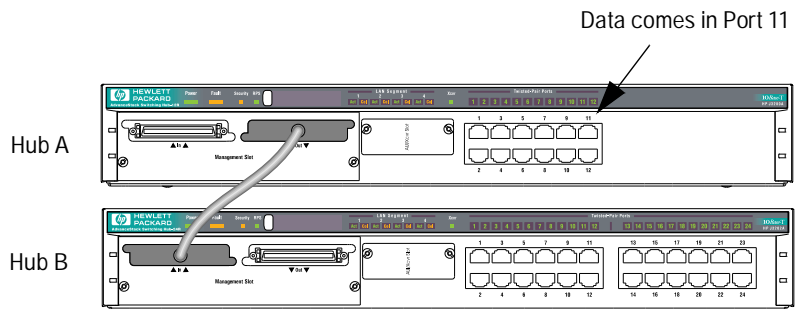

If users are distributed on the different segments via a Management Module, then data received on a segment is only transferred out the same segment.

Collision Detection

The hub performs collision detection. A collision occurs when two nodes try to transmit at the same time. When the hub detects this, it stops repeating the colliding transmissions and starts transmitting a jamming signal. The jamming signal tells the transmitting nodes that a collision has occurred. The colliding nodes then stop transmitting for a random amount of time before attempting to retransmit the data. Once the collision condition is removed, the hub stops transmitting the jamming signal and normal operation is resumed.

If the Col LED is on most of the time because of high traffic levels, you can optimize your network by separating nodes onto different segments. Each segment is a collision domain. By adding the optional Management Module to your stack of hubs, you can use management software to specify which segment each node will be placed on.

Auto-Partitioning

The hub will automatically partition (temporarily disable) a network port for the following reasons:

- a collision condition exists for an excessive duration (between 1024 and 2048 bit times)
- a collision occurs during each of 32 consecutive attempts to transmit
- Installed optional transceiver has SQE test enabled instead of disabled

The hub monitors the partitioned port and automatically re-enables the port when a minimum length packet can be successfully transmitted or received without a collision occurring.

Excessive collisions may be caused by faulty wiring. If a port's transmit (Tx +/-) wires have been shorted to the receive (Rx +/-) wires of any port, a collision will be detected when that port attempts to transmit. If a port's receive (Rx +/-) wires are not connected properly, collisions will occur because the hub cannot detect the presence of network traffic on that port and may thus transmit at inappropriate times.

A port may occasionally also become partitioned when network traffic is extremely heavy causing an abnormally high collision rate. If collisions are high, distribute your users onto two, three or four segments using the optional Management Module.

Link Beat

Type 10Base-T devices use a signal called link beat (also called link test pulse). This signal informs the hub of the presence of a device connected to it over twisted-pair cable and of the integrity of the twisted-pair link between them. The hub will not transmit packets out of twisted-pair ports that do not sense the link beat signal. Link beat is reflected in the port LEDs; the LED will be on:

Link beat status shown in Port LEDs

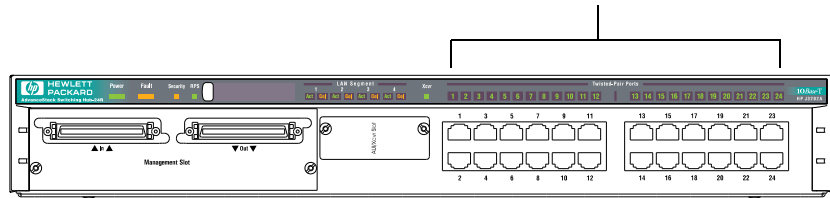

Optimizing Your Network

If your Col(ision) and/or Act(ivity) LEDs are mostly on rather than flickering, you can optimize your network by adding these optional modules:

- **Management Module and Switch Module** to *automatically* distribute users onto the different segments
- **Management Module only** to *manually* distribute users over your network onto the different segments

Because the Switch Module needs a Management Module in the stack, you can configure, troubleshoot, and monitor your network with either setup.

Note

You can also add additional LAN adapters to your server or an external switch to communicate with the Switching Hubs. See those products documentation for more information.

This chapter describes the following topics:

- automatically segmenting your network using an internal or external switch
- features of the internal Switch Module
- features of the Management Module

Automatically Segmenting Your Network

If you have multiple servers connected to your hubs, you can improve access time to the servers by adding a switch. You can add an internal switch module or external switch.

Reasons for Using an Internal vs. External Switch

Some of the main differences between an internal and external switch are listed in below.

Reasons to use an Internal Switch Module	Reasons to Use an External Switch
Need an inexpensive performance boost within a 10Base-T framework	Need higher performance boost (fat pipe, switched 10Base-T to desktop)
Need just basic management plus auto-configuration and load balancing features	Require full management: spanning tree dropped packet detection
No pre-configured bridging or switching	Pre-configured bridging or switching on network
Half duplex to servers is adequate	Need full duplex speed to servers

For information on HP external switches, contact your HP authorized dealer or reseller. For more information on an external switch, contact the manufacturer of the switch.

HP Internal Switch Module Features

The plug-and-play HP J3212A AdvanceStack 10BT Switch Module inserts into the Expansion Slot of your Switch Hub.

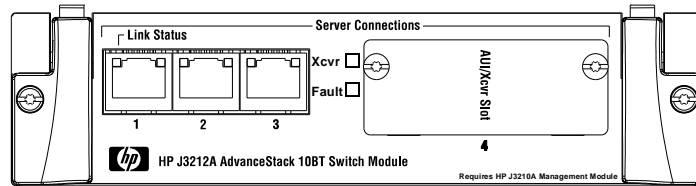

The features of the Switch Module are:

- **Automatic Port Switching.** If you have not changed the port configuration in the ASCII console or HP AdvanceStack Assistant (setting up security, disabling ports), the Management Module will move the ports onto the four different segments for you automatically on power up.
- **Load Balancing.** In both the ASCII console and HP AdvanceStack Assistant, you can select Load Balancing and the software will examine your network traffic, and redistribute the ports to balance the network load.
- **Connect the Segments Together.** Users on one segment can communicate with the users on another segment through the Switch Module backplane.

The Switch Module has four external ports. The Xcvr (Transceiver) port supports twisted-pair, thin coax, and fiber media for external connections to servers at 10 Mbit/s. Internally, the Switch Module connects to the four segments in the hub stack.

Because the Switch Module requires a Management Module in a managed stack, you get all of the features of the Management Module described on the next page for your hub stack.

Managing Your Network with the Management Module

By adding the optional HP J3210A Management Pack to any hub in your stack, you can configure, diagnose, and troubleshoot your stack of hubs.

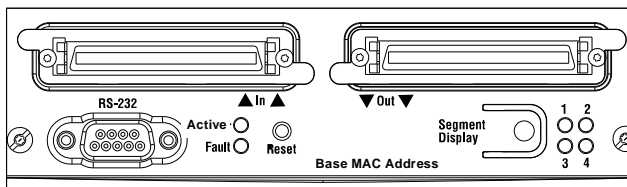

The features of this module are:

- **Port Switching.** The ability to distribute any stack ports onto 4 available segments. By distributing ports onto different collision domains, the number of collisions are reduced and bandwidth increases for each user.
- **Network Management through Two Included Software Interfaces.** Segment, diagnose, configure, and manage your stack of hubs through either the ASCII console (through a serial cable or by using Telnet) or through the graphical software package, HP AdvanceStack Assistant. Using either interface from a network management station that supports Management over IP (using the configured IP address) or Novell NetWare (IPX), you can remotely manage the stack of hubs. The Management Module has SNMP, RMON, and HP EASE (Embedded Advanced Sampling Environment).
- **Segment Display.** The Management Module has a Segment Display button. By pressing the Segment Display button one time for each segment, all Port LEDs in the entire stack will reflect which segment each port is on. After 60 seconds, the Port LEDs revert to displaying their connection status information rather than segment information.
- **Security** Multiple levels of security and network management authorization for every port in the stack. The console can also be configured to have a password before the user logs in.
- **Redundant backup link** to another device to enhance network fault tolerance for every port in the stack.
- **Redundant Management Modules.** If you insert two Management Modules into a stack, the second module will take over if the first one fails to give you uninterrupted management.

Troubleshooting

This chapter describes how to troubleshoot your stack of hubs. Note that if you have a Management Module, you can troubleshoot your hubs using software. See the Management Module manual for more information.

This chapter describes how to troubleshoot your hub using:

- solutions to common problems
- LEDs
- diagnostic tests

Solutions to Common Problems

Most problems are caused by the following situations:

- **Incorrect Hub-to-Hub connections.** In addition to Extender Cable hub-to-hub connections, you used crossover cable, thin coax, or fiber cable to make hub-to-hub connections. Remove Switching Hub-to-Switching Hub connections other than the Extender Cable.
- **Loopback.** Verify the Extender cable is not looped back to the same hub:

Incorrect

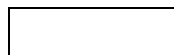
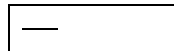

Correct

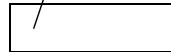

- **Incorrect cable lengths.** *Maximum cable lengths are in the HP Switching Hubs Installation Guide.*
- **Bad cable or cable is not snug.** Look for loose connections. If snug, try a different cable.
- **Nonstandard cables.** Miswired cables may cause numerous network collisions, and can seriously impair network performance. Use a new correctly wired cable or compare your cable to the cable in appendix A, “Cables and Connectors” for pinouts and correct cable wiring.

LED Error Indications

Use the following table to troubleshoot your stack of hubs using the LEDs.

LED patterns indicating problems						Diagnostic Tips
Power	Collision	Fault	Security	RPS	Port	
OFF	*	*	*	*	*	Check power cord and power source. If OK, replace hub.
ON	*	OFF	OFF	*	OFF or flashing intermittently	Link beat has not been detected. Check that the cabling on the indicated port is connected properly. Bad cables are common; try a different cable. If you have a Management Module in the stack, use HP AdvanceStack Assistant or the ASCII console to determine the state of the port: - Determine if the port was disabled. Re-enable if desired.
ON	Appears solidly ON	*	*	*	*	Very frequent collisions could indicate a network fault or improperly terminated cable. A transceiver attached to the AUI port may not have the SQE test disabled.
ON	*	Slow Flash	OFF	*	Slow Flash	The port has automatically been partitioned because of too many collisions. Check cable terminations, connections, SQE setting on any external transceivers, and status of attached network devices for causes of the excess collisions.
ON	*	Slow Flash	*	Slow Flash	*	The Redundant Power Supply (RPS) may no longer be providing redundant power. See the documentation provided with the RPS for troubleshooting.
OFF	*	*	*	OFF	*	The hub is not receiving power from the Redundant Power Supply (RPS) or the cable connection is loose. If you have an RPS connected, check the cable connections and the RPS LED.
ON	*	*	Rapid Flash	*	Rapid Flash	An unauthorized user has tried to access the hub. The port is now disabled. Use the ASCII console or HP AdvanceStack Assistant to clear the violation.
ON	*	*	Rapid Flash	*	Not Flashing	An unauthorized network management station has attempted to access a hub. Use the ASCII console or HP AdvanceStack Assistant to clear the violation.

LED patterns indicating problems						Diagnostic Tips
Power	Collision	Fault	Security	RPS	Port	
ON	*	ON	ON	*	Variable, all may be ON	<p>A hub hardware failure was detected during self-test. Self-test does not complete so the LEDs will stay on longer than 60 seconds.</p> <p>Power cycle the hub. If this condition persists, the hub may have to be replaced. Contact your HP-authorized LAN dealer or HP representative for assistance.</p>
<p>* This LED is not important for the diagnosis. The slow flash is approximately once every 1.5 seconds, the rapid flash is approximately three times per second.</p>						

Diagnostic Tests

When a Management Module is installed, the HP AdvanceStack Assistant and ASCII console software provide tests and indicators that can be used to monitor the hub and its network connections. See the Management Module manual for more information.

Testing the Hub or Stack of Hubs

If you believe that the hub is not operating correctly, you can reset the hub to test the hub's circuitry by removing the power cable to that hub. To reset a stack, either:

- Remove and reinsert the power cord for each hub.
- Press the Reset button on an optional Management Module
- Select Reset in HP AdvanceStack Assistant or the ASCII console (software is provided with the HP Management Module)

Testing Twisted-Pair Cabling

If you think the cable should work but still isn't working, it may not be compatible with the IEEE 802.3 Type 10Base-T standard. The twisted-pair cable attached to the HP Switching Hub must be compatible with this standard. To verify that your cable is compatible with this standard, you can use the HP J2263A Cable Test Set.

The older HP 28687A Wire Test Instrument can also be used. If you would rather have HP test the cable, HP offers a wire testing service. Contact your HP-authorized LAN dealer or your local HP sales office for more information.

HP Customer Support Services

If you are still having trouble with your stack of hubs, see the perforated card at the beginning of this manual.

Cables and Connectors

This appendix lists cables that have been tested and verified for use with the HP Switching Hubs. It also includes minimum pin-out information so, if you wish to use an unlisted cable, you can verify that the cables used in your installation are correctly wired. Note that each pin-out does not necessarily match the pin-out for the corresponding HP cable, but cables manufactured to follow the minimum pin-out will function correctly.

Note

Incorrectly wired cabling is the most common cause of problems for LAN communications. HP recommends that you work with a qualified LAN cable installer for assistance with your cabling requirements.

Recommended Cables

Connection	Cable Type	HP Product Number
Switching Hub to Switching Hub	Extender Cable	5182-9814 71cm (12.5 inch) 5182-9869 31.8 cm ((28 inch)
Hub to end node connection	Twisted-pair "straight-through" cable	92268A, B, C, D, or N (4-pair) 92214R, S, or T (25-pair)

To connect an HP Switching Hub to any Ethernet hub, use a "crossover" cable. See that hub's manual for crossover cable pin-outs.

You can contact your HP authorized dealer or call HP at 1-800-538-8787 to order these parts.

Twisted-Pair Cable/Connector Pin-Outs

Twisted-Pair Cable for Hub-to-Computer Network Connection

To connect PCs or other network devices to the hub, use a “straight-through” Category 3, 4, or 5 cable. The twisted-pair wires must be twisted through the entire length of the cable. The wiring sequence must conform to AT&T 258A (not USOC). See “Twisted-Pair Cable Pin Assignments” later in this chapter for a listing of the signals used on each pin.

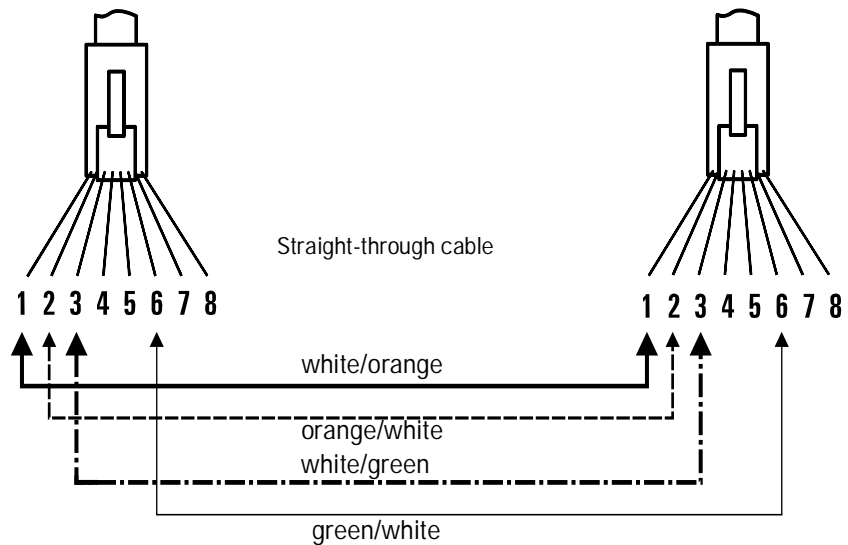

Note

Pins 1 and 2 *must* be a twisted pair.
Pins 3 and 6 *must* be a twisted pair.

Pins 4, 5, 7, and 8 are not used in this application, although they may be wired in the cable.

Twisted-Pair Cable Pin Assignments

Twisted-Pair Straight-Through Cable

Hub End			Computer or Transceiver End	
Signal	Pins		Pins	Signal
(receive +)	1	←	1	(transmit +)
(receive -)	2	←	2	(transmit -)
(transmit +)	3	→	3	(receive +)
(transmit -)	6	→	6	(receive -)

Specifications

Physical

Width	44.2 cm (17.4 in)
Depth	29.8 cm (11.7 in)
Height	6.6 cm
Weight	
Hub-12R	4.4 kg (9.71 lb)
Hub-24R	4.5 kg (9.95 lb)
Hub-24T	4.4 kg (9.75 lb)

Electrical

The Switching Hubs automatically adjusts to any voltage between 100-127 and 200-240 volts and either 50 or 60 Hz.)

AC voltage:	100-127 volts	200-240 volts
Maximum current:	1.1 A	0.6 A
Frequency range:	50/60 Hz	50/60 Hz

The maximum current ratings represent the current that could be drawn with a fully loaded expansion slot and external MAU's.

Environmental

	Operating	Non-Operating
Temperature	+0°C to +55°C (32°F to 131°F)	-40°C to 70°C (-40°F to 158°F)
Relative humidity (non-condensing)	15% to 95% at 40°C (104°F)	15% to 90% at 65°C (149°F)
Maximum altitude	4.6 km (15,000 ft)	4.6 km (15,000 ft)

Connectors

The 50-pin and RJ-45 twisted-pair ports are compatible with the IEEE 802.3 Type 10Base-T standard.

Electromagnetic

Emissions with *unshielded* cables

Verified to:
FCC part 15 Class A
CISPR22 / EN55022 Class A
VCCI Class 1

Emissions with *shielded* cables

Verified to:
FCC part 15 Class B
CISPR22 / EN55022 Class B
VCCI Class 2

Immunity

EN50082-1

See the Declaration of Conformity for additional information at the end of this chapter.

Safety

Complies with

IEC 950: (1991)+A1,A2/.EN60950 I(1992)+A1,A2

UL1950

CSA 950

NOM-019-SCFI-1993

Acoustic Noise

Geraeuschemission LwA=53 dB am fiktiven Arbeitsplatz nach DIN 45635 T.19

Safety and Regulatory Statements

This chapter covers the following topics:

- mounting precautions
- power precautions
- safety and regulatory statements
- Declaration of Conformity

Mounting Precautions

When you put a hub into a rack, follow these mounting precautions:

- The rack or cabinet should be adequately secured to prevent it from becoming unstable and/or falling over. The first hub (or single hub) should be mounted in a position toward the bottom of the rack for stability and to make it easier to stack the other hubs on top.
- Before mounting a hub, plan its location and orientation relative to other devices and equipment. Also consider the cabling that will be attached to the hub and the ports that will be used. Verify that there is room for the grouped cables to trail out from the side of the hub. Allow at least 2.54 cm (1 inch) in the front of the hub. In the back of the hub, allow at least 3.8 cm (1 1/2 inches) of space for the power cord.
- Ensure that the HP Switching Hub(s) do not overload the power circuits, wiring, and over-current protection. To determine the possibility of overloading the supply circuits, add together the amperage ratings from the nameplates of all your hubs (and other equipment) installed on the same circuits and compare the total with the rating limits for the supply circuits.
- Make sure that the power source circuits are properly grounded, then use the supplied power cord to connect the HP Switching Hub to the circuit. *See the Safety Statements in this chapter.*
- Do not install the hub in an environment where the operating ambient temperature might exceed 55°C (131°F).
- Make sure the air flow around the sides of the hub is not restricted.

Power Precautions

Follow these precautions when unplugging and plugging in power to the hub as well as adding or removing modules.

Warning



Before installing an optional module into the Expansion Slot, Management Slot, or transceiver slot, unplug the hub. Electrical shock or other injury can result if you attempt to install the module without unplugging the hub. If you do not install an optional module, verify that the cover plates are covering the slot. A cover plate is required not only for safety, but also to ensure proper hub cooling. The rack or cabinet should be adequately secured to prevent it from becoming unstable and/or falling over.

Caution

If your installation requires a different power cord than the one supplied with the hub, be sure to use a power cord displaying the mark of the safety agency that defines the regulations for power cords in your country. The mark is your assurance that the power cord can be used safely with the hub.

Note

The hub does not have a power switch; it is powered on when the power cord is plugged in. The hub's power supply automatically adjusts to any AC power source between 100-127 volts and 200-240 volts. There are no voltage range settings to configure.

When installing the hub, note that the AC outlet must be installed near the equipment and should be easily accessible.

Safety Information



Documentation reference symbol. If the product is marked with this symbol, refer to the product documentation to get more information about the product.

WARNING

A WARNING in the manual denotes a hazard that can cause injury or death.

CAUTION

A CAUTION in the manual denotes a hazard that can damage equipment.

Do not proceed beyond a WARNING or CAUTION notice until you have understood the hazardous conditions and have taken appropriate steps.

Grounding

These are safety class I products and have protective earthing terminals. There must be an uninterruptible safety earth ground from the main power source to the product's input wiring terminals, power cord, or supplied power cord set. Whenever it is likely that the protection has been impaired, disconnect the power cord until the ground has been restored.

For LAN cable grounding:

- If your LAN covers an area served by more than one power distribution system, be sure their safety grounds are securely interconnected.
- LAN cables may occasionally be subject to hazardous transient voltages (such as lightning or disturbances in the electrical utilities power grid). Handle exposed metal components of the network with caution.

Servicing

There are no user-serviceable parts inside these products. Any servicing, adjustment, maintenance, or repair must be performed only by service-trained personnel.

These products do not have a power switch; they are powered on when the power cord is plugged in.

Informations concernant la sécurité



Symbole de référence à la documentation. Si le produit est marqué de ce symbole, reportez-vous à la documentation du produit afin d'obtenir des informations plus détaillées.

WARNING

Dans la documentation, un WARNING indique un danger susceptible d'entraîner des dommages corporels ou la mort.

CAUTION

Un texte de mise en garde intitulé CAUTION indique un danger susceptible de causer des dommages à l'équipement.

Ne continuez pas au-delà d'une rubrique WARNING ou CAUTION avant d'avoir bien compris les conditions présentant un danger et pris les mesures appropriées.

Cet appareil est un produit de classe I et possède une borne de mise à la terre. La source d'alimentation principale doit être munie d'une prise de terre de sécurité installée aux bornes du câblage d'entrée, sur le cordon d'alimentation ou le cordon de raccordement fourni avec le produit. Lorsque cette protection semble avoir été endommagée, débrancher le cordon d'alimentation jusqu'à ce que la mise à la terre ait été réparée.

Mise à la terre du câble de réseau local:

- si votre réseau local s'étend sur une zone desservie par plus d'un système de distribution de puissance, assurez-vous que les prises de terre de sécurité soient convenablement interconnectées.
- Les câbles de réseaux locaux peuvent occasionnellement être soumis à des surtensions transitoires dangereuses (telles que la foudre ou des perturbations dans le réseau d'alimentation public). Manipulez les composants métalliques du réseau avec précautions.

Aucune pièce contenue à l'intérieur de ce produit ne peut être réparée par l'utilisateur. Tout dépannage, réglage, entretien ou réparation devra être confié exclusivement à un personnel qualifié.

Cet appareil ne comporte pas de commutateur principal ; la mise sous tension est effectuée par branchement du cordon d'alimentation.

Hinweise zur Sicherheit



Symbol für Dokumentationsverweis. Wenn das Produkt mit diesem Symbol markiert ist, schlagen Sie bitte in der Produktdokumentation nach, um mehr Informationen über das Produkt zu erhalten.

WARNING

Symbol für Dokumentationsverweis. Wenn das Produkt mit diesem Symbol markiert ist, schlagen Sie bitte in der Produktdokumentation nach, um mehr Informationen über das Produkt zu erhalten.

CAUTION

Symbol für Dokumentationsverweis. Wenn das Produkt mit diesem Symbol markiert ist, schlagen Sie bitte in der Produktdokumentation nach, um mehr Informationen über das Produkt zu erhalten.

Fahren Sie nach dem Hinweis WARNING oder CAUTION erst fort, nachdem Sie den Gefahrenzustand verstanden und die entsprechenden Maßnahmen ergriffen haben.

Dies ist ein Gerät der Sicherheitsklasse I und verfügt über einen schützenden Erdungsterminal. Der Betrieb des Geräts erfordert eine ununterbrochene Sicherheitserdung von der Hauptstromquelle zu den Geräteingabeterminals, den Netzkabeln oder dem mit Strom belieferten Netzkabelsatz voraus. Sobald Grund zur Annahme besteht, daß der Schutz beeinträchtigt worden ist, das Netzkabel aus der Wandsteckdose herausziehen, bis die Erdung wiederhergestellt ist.

Für LAN-Kabelerdung:

- Wenn Ihr LAN ein Gebiet umfaßt, das von mehr als einem Stromverteilungssystem beliefert wird, müssen Sie sich vergewissern, daß die Sicherheitserdungen fest untereinander verbunden sind.
- LAN-Kabel können gelegentlich gefährlichen Übergangsspannungen ausgesetzt werden (beispielsweise durch Blitz oder Störungen in dem Starkstromnetz des Elektrizitätswerks). Bei der Handhabung exponierter Metallbestandteile des Netzwerkes Vorsicht walten lassen.

Dieses Gerät enthält innen keine durch den Benutzer zu wartenden Teile. Wartungs-, Anpassungs-, Instandhaltungs- oder Reparaturarbeiten dürfen nur von geschultem Bedienungspersonal durchgeführt werden.

Dieses Gerät hat keinen Netzschalter; es wird beim Anschließen des Netzkabels eingeschaltet.

Considerazioni sulla sicurezza



WARNING

Simbolo di riferimento alla documentazione. Se il prodotto è contrassegnato da questo simbolo, fare riferimento alla documentazione sul prodotto per ulteriori informazioni su di esso.

La dicitura WARNINGdenota un pericolo che può causare lesioni o morte.

CAUTION

La dicituraCAUTION denota un pericolo che può danneggiare le attrezzature.

Non procedere oltre un avviso di WARNING o di CAUTIONprima di aver compreso le condizioni di rischio e aver provveduto alle misure del caso.

Questo prodotto è omologato nella classe di sicurezza I ed ha un terminale protettivo di collegamento a terra. Dev'essere installato un collegamento a terra di sicurezza, non interrompibile che vada dalla fonte d'alimentazione principale ai terminali d'entrata, al cavo d'alimentazione oppure al set cavo d'alimentazione fornito con il prodotto. Ogniqualevolta vi sia probabilità di danneggiamento della protezione, disinserite il cavo d'alimentazione fino a quando il collegaento a terra non sia stato ripristinato.

Per la messa a terra dei cavi LAN:

- se la vostra LAN copre un'area servita da più di un sistema di distribuzione elettrica, accertatevi che i collegamenti a terra di sicurezza siano ben collegati fra loro;
- i cavi LAN possono occasionalmente andare soggetti a pericolose tensioni transitorie (ad esempio, provocate da lampi o disturbi nella griglia d'alimentazione della società elettrica); siate cauti nel toccare parti esposte in metallo della rete.

Nessun componente di questo prodotto può essere riparato dall'utente. Qualsiasi lavoro di riparazione, messa a punto, manutenzione o assistenza va effettuato esclusivamente da personale specializzato.

Questo apparato non possiede un commutatore principale; si mette scotto tensione all'inserirsi il cavo d'alimentazione.

Consideraciones sobre seguridad



Símbolo de referencia a la documentación. Si el producto va marcado con este símbolo, consultar la documentación del producto a fin de obtener mayor información sobre el producto.

WARNING

Una WARNING en la documentación señala un riesgo que podría resultar en lesiones o la muerte.

CAUTION

Una CAUTION en la documentación señala un riesgo que podría resultar en averías al equipo.

No proseguir después de un símbolo de WARNING o CAUTION hasta no haber entendido las condiciones peligrosas y haber tomado las medidas apropiadas.

Este aparato se enmarca dentro de la clase I de seguridad y se encuentra protegido por una borna de puesta a tierra. Es preciso que exista una puesta a tierra continua desde la toma de alimentación eléctrica hasta las bornas de los cables de entrada del aparato, el cable de alimentación o el juego de cable de alimentación suministrado. Si existe la probabilidad de que la protección a tierra haya sufrido desperfectos, desenchufar el cable de alimentación hasta haberse subsanado el problema.

Puesta a tierra del cable de la red local (LAN):

- Si la LAN abarca un área cuyo suministro eléctrico proviene de más de una red de distribución de electricidad, cerciorarse de que las puestas a tierra estén conectadas entre sí de modo seguro.
- Es posible que los cables de la LAN se vean sometidos de vez en cuando a voltajes momentáneos que entrañen peligro (rayos o alteraciones en la red de energía eléctrica). Manejar con precaución los componentes de metal de la LAN que estén al descubierto.

Este aparato no contiene pieza alguna susceptible de reparación por parte del usuario. Todas las reparaciones, ajustes o servicio de mantenimiento debe realizarlos solamente el técnico.

Este producto no tiene interruptor de potencia; se activa cuando se enchufa el cable de alimentación.

Safety Information (Japanese)

安全性の考慮

安全記号



マニュアル参照記号。製品にこの記号がついている場合はマニュアルを参照し、注意事項等をご確認ください。

WARNING マニュアル中の「WARNING」は人身事故の原因となる危険を示します。

CAUTION マニュアル中の「CAUTION」は装置破損の原因となる危険を示します。

「WARNING」や「CAUTION」の項は飛ばさないで必ずお読みください。危険性に関する記載事項をよく読み、正しい手順に従った上で次の事項に進んでください。

これは安全性クラス I の製品で保護用接地端子を備えています。主電源から製品の入力配線端子、電源コード、または添付の電源コード・セットまでの間、切れ目のない安全接地が存在することが必要です。もしこの保護回路が損なわれたことが推測されるときは、接地が修復されるまで電源コードを外しておいてください。

LAN ケーブルの接地に関して:

- もし貴社の LAN が複数の配電システムにより電力を受けている領域をカバーしている場合には、それらのシステムの安全接地が確実に相互に結合されていることを確認してください。
- LAN ケーブルは時として危険な過度電圧（例えば雷や、配電設備の電力網での障害）にさらされることがあります。露出した金属部分の取扱いには十分な注意をはらってください。

本製品の内部にはユーザーが修理できる部品はありません。サービス、調整、保守および修理はサービス訓練を受けた専門家におまかせください。

本製品には電源スイッチがありません。電源コードを接続したとき電源入となります。

Regulatory Statements

FCC Class A Statement (for U.S.A. Only) when using unshielded cables:

This equipment has been tested and found to comply with the limits for a Class A digital device, pursuant to Part 15 of the FCC Rules. These limits are designed to provide reasonable protection against harmful interference when the equipment is operated in a commercial environment. This equipment generates, uses, and can radiate radio frequency energy and, if not installed and used in accordance with the instruction manual, may cause harmful interference to radio communications. Operation of this equipment in a residential area may cause harmful interference in which case the user will be required to correct the interference at his own expense.

FCC Class B Statement (for U.S.A. Only) when using shielded cables:

This equipment has been tested and found to comply with the limits for a Class B digital device, pursuant to Part 15 of the FCC Rules. These limits are designed to provide reasonable protection against interference in a residential installation. This equipment generates, uses and can radiate radio frequency energy and, if not installed and used in accordance with the instructions, may cause interference to radio communications. However, there is no guarantee that interference will not occur in a particular installation. If this equipment does cause interference to radio or television reception, which can be determined by turning the equipment off and on, the user is encouraged to try to correct the interference by one or more of the following measures:

- Reorient or relocate the receiving antenna.
- Increase the separation between the equipment and receiver.
- Connect the equipment into an outlet on a circuit different from that to which the receiver is connected.
- Consult the dealer or an experienced radio/TV technician for help.

VCCI Class 1 (For Japan Only) when using unshielded cables

注意

この装置は、情報処理装置等電波障害自主規制協議会（VCCI）の基準に基づく第一種情報技術装置です。この装置を家庭環境で使用すると電波妨害を引き起こすことがあります。この場合には使用者が適切な対策を講ずるよう要求されることがあります。

VCCI Class 2 (For Japan Only) when using shielded cables

この装置は、情報処理装置等電波障害自主規制協議会（VCCI）の基準に基づく第二種情報技術装置です。この装置は、家庭環境で使用することを目的としていますが、この装置がラジオやテレビジョン受信機に近接して使用されると、受信障害を引き起こすことがあります。
取り扱い説明書に従って正しい取り扱いをして下さい。



European Community

This equipment complies with ISO/IEC Guide 22 and EN55022 Class A with unshielded cables and EN55022 Note

With unshielded cables this is a Class A product. In a domestic environment, this product may cause radio interference, in which case the user may be required to take adequate measures.

Canada

This product complies with Class A Canadian EMC requirements when using unshielded cables and Class B EMC requirements when using shielded cables..

Declaration of Conformity

The following Declaration of Conformity for the HP AdvanceStack 10BT Switching Hubs complies with ISO/IEC Guide 22 and EN 45014. The declaration identifies the product, the manufacturer's name and address, and the applicable specifications that are recognized in the European community.

DECLARATION OF CONFORMITY according to ISO/IEC Guide 22 and EN45014	
Manufacturer's Name:	Hewlett-Packard Company
Manufacturer's Address:	8000 Foothills Blvd. Roseville, CA 95747-5502 U.S.A.
declares that the product:	
Product Name:	HP AdvanceStack 10BT Switching Hub-12R HP AdvanceStack 10BT Switching Hub-24R HP AdvanceStack 10BT Switching Hub-24T
Model Number:	HP J3200A, HP J3202A, HP J3204A
Accessories covered:	HP J2606A, HP J2607A, HP J2608A, HP J2609A, HP J3210A, HP J3212A
conforms to the following Product Specifications:	
Safety:	IEC 950:1991+A1,A2/EN60950 (1992)+A1,A2
EMC:	EN 55022 (1994) / CISPR-22 (1993) class A EN 55022 (1994) / CISPR-22 (1993) class B* EN50082-1 (1992) prEN 55024-2 (1992) / IEC 801-2 (1991) 4 kV CD, 8 kV AD prEN 55024-3 (1991) / IEC 801-3 (1984), 3 V/m prEN 55024-4 (1992) / IEC 801-4 (1988): 1 kV-(power line) 0.5 kV-(signal line)
Supplementary Information:	
The product herewith complies with the requirements of the Low Voltage Directive 73/23/EEC and the EMC Directive 89/336/EEC and carries the CE marking accordingly. LED's in this product(s) are Class-1 in accordance with EN60825-1:1994.	
*The J3200A, J3202A, and J3204A have been tested to and pass Class B when shielded network cables are used.	
Tested with Hewlett-Packard Co. products only.	
Roseville, July 8, 1996	
Sandra L. Sheehan, Quality Manager	
European Contact: Your local Hewlett-Packard Sales and Service Office or Hewlett-Packard GmbH, Department: TRE, Herrenberger Strasse 130, D-71034 Boblingen (FAX:+49-7081-14-3143).	

Index

A

auto-segmentation
 See partitioning

B

backup Management Modules ... 2-4
blinking rates
 definition for ... 1-3

C

cables
 managing ... 1-7
 twisted-pair connector pin-outs ... A-2
category 3, 4, 5 cables ... A-2
collision detection ... 1-8

D

diagnostic tests ... 3-3
 testing the hub only ... 3-3
 testing twisted-pair cabling ... 3-4
distance of Extender Cables ... 1-6

E

Expansion Slot
 allowed modules ... 1-7
 LEDs for ... 1-2
Extender Cables
 repeater hop info ... 1-5
 stack maximum ... 1-5
external switch differences ... 2-2

F

Fault LED ... 1-2
flash rates
 definitions for ... 1-3

H

HP AdvanceStack Assistant ... 2-4

HP Interconnect Manager
 See HP AdvanceStack Assistant
HP Redundant Power Supply (RPS)
 connector ... 1-7
 LED ... 1-2

hub

 identification ... 1-4
 operation ... 1-8

I

Interconnect Manager
 See HP AdvanceStack Assistant

L

LEDs
 Act ... 1-3
 Col ... 1-3
 Expansion Slot ... 1-2
 Fault ... 1-2
 flashing rate definitions ... 1-3
 LAN Segment 1-4 ... 1-3
 Power ... 1-2
 RPS ... 1-2
 Security ... 1-2
 Twisted-Pair Ports ... 1-3
 Xcvr ... 1-3
length of Extender Cables ... 1-6
link beat ... 1-10
load balancing ... 2-3

M

MAC address
 for each segment ... 1-4
management module features ... 2-3

O

on/off switch
 See resetting the hub
OUT port ... 1-6

P

- partitioning ... 1-9
- port mobility
 - See* port switching
- port switching ... 2-4
- power connector ... 1-7
- Power LED ... 1-2
- power supply, additional
 - See* HP Redundant Power Supply

R

- rapid flash rate definition ... 1-3
- redundant backup link ... 2-4
- repeater hop count ... 1-5
- resetting the hub
 - troubleshooting procedure ... 3-3
- RPS (Redundant Power Supply) LED ... 1-2

S

- Security
 - feature in Management Module ... 2-4
 - LED ... 1-2
- Segment Display button ... 2-4
- segments
 - connecting together ... 2-3
- slow flash rate definition ... 1-3
- stack order ... 1-6
- stack to stack connections ... 1-6
- Switch Module features ... 2-3
- switches
 - internal vs. external ... 2-2

T

- testing
 - hubs ... 1-4
 - twisted-pair cabling ... 3-4
- troubleshooting ... 3-1
 - diagnostic tests ... 3-3
 - testing the hub ... 3-3
 - testing the twisted-pair cables ... 3-4
- twisted-pair cable
 - hub-to-computer connection ... A-2
 - pin-outs ... A-2
 - testing ... 3-4
- twisted-pair ports LEDs ... 1-3

X

- Xcvr (Transceiver) LED ... 1-3